

## GENERAL COLOR -RECEIVER DESIGN CONSIDERATIONS \*

## COMPLETE COLOR SIGNAL

Acquaintance with the complete color television signal is necessary before it is possible to discuss color receivers. This signal consists of the normal monochrome television signal (i. e. luminance, deflection sync, and sound signals) to which the coloring information has been added. This added information consists of a modulated color subcarrier, called the chrominance signal, and a color synchronizing signal which supplies a phase reference for the chrominance signal. Black-and-white receivers reproduce only the luminance and sound. Color television receivers must, in addition, insert the coloring information present in the chrominance subcarrier into the black-and-white picture.

The spectrum of the complete color signal is shown in Fig. 1, which indicates the frequency relations between the luminance, the frequency-interleaved chrominance, and the sound signals. The time and amplitude interrelations between the luminance signal ( $E_Y$ '), chrominance subcarrier, horizontal sync, and color sync are shown in Fig. 2 for one line of saturated color bars. The luminance signal is shown as a heavy line which serves as an axis for the added chrominance. The color synchronizing signal, in the form of a burst of 8 to 11.5 cycles of the unmodulated subcarrier, follows the horizontal sync on the blanking pedestal. (The pedestal shown in Fig. 2 has recently been deleted from the NTSC specifications.)

The complete color signal can be expressed by the following relations:

The complete color signal is<sup>1,2</sup>

$$E_m = E_Y + M_1 [M_2 (E_B - E_Y) \sin \omega t + (E_R - E_Y) \cos \omega t], (1)$$

where  $E_Y$  is the luminance signal and is given by

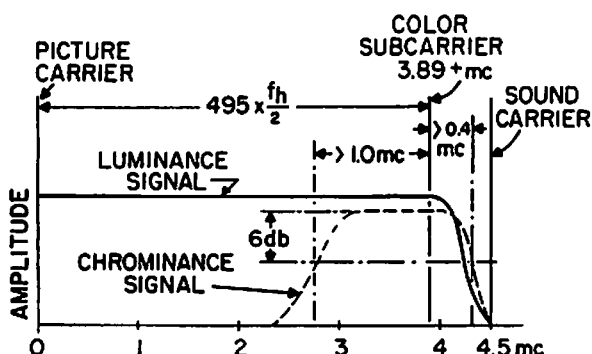

Fig. 1 - Spectrum of Complete Color Signal

$$E_Y = 0.59 E_G + 0.30 E_R + 0.11 E_B, (2)$$

$$\text{and } M_1 [M_2 (E_B - E_Y) \sin \omega t + (E_R - E_Y) \cos \omega t] (3)$$

is the chrominance signal.

The quantities  $E_G$ ,  $E_R$ , and  $E_B$  are the voltages at the output of the green, red, and blue channels of the camera after gamma correction. The values of the constants  $M_1$  and  $M_2$  are:

$$M_1 = 0.88; \text{ and } M_2 = 0.56.$$

The relation between  $(E_G - E_Y)$ ,  $(E_R - E_Y)$ , and  $(E_B - E_Y)$  is expressed by

$$(E_G - E_Y) = -[0.51 (E_R - E_Y) + 0.19 (E_B - E_Y)]. (4)$$

## COMPONENTS OF COLOR RECEIVERS

The essential components of a color receiver are illustrated in the block diagram of Fig. 3, which shows:

The RF and IF amplifiers and second detector (block #1);

The luminance amplifier (2);

The chrominance amplifier, which includes:

The bandpass amplifier (3);

The R-Y demodulator (6);

The B-Y demodulator (8);

The G-Y matrix (11);

The color reference generator (7);

The CPA switch (4) and CPA synchronizing generator (5);

The adders (12, 13, and 14) which combine the luminance and chrominance signals to form primary-color signals;

The tricolor tube (15).

The sound system, scanning circuits, and the circuits (other than the signal circuits) which are required for operation of the tricolor tube are not shown.

\* Presented at the Radio Fall Meeting of IRE and RTMA, Syracuse, N. Y., October 21, 1952, at the Symposium on NTSC Color Television Receiver Development sponsored by the IRE Professional Group on Broadcast and Television Receivers.

<sup>1,2</sup> Reference numerals indicate items of the bibliography on Page 14.

**DIRECT COUPLING VS. AC COUPLING**

While receivers with direct-coupled video amplifiers have an advantage over the AC-coupled type in the presence of impulse noise (because of the charging of the DC reinsetters by the noise) some DC-coupled arrangements may introduce interrelations between the different circuits which make the design difficult to alter or service. This is because biases and operating levels for the luminance and color-difference signals should be maintained for the three guns of the picture tube for all values of line voltage, load conditions, and component drift. For this reason it may be preferable to build AC-coupled receivers until enough experience is gained to avoid the need of repeated redesign of the interrelated circuits.

**VIDEO DRIVES**

Because of differences in the efficiencies of the three phosphors, different beam currents are required in each of the three guns to produce a white corresponding to standard illuminant "C". In early receivers equal video drives were applied to each of the guns and the required beam current ratios were obtained by suitable adjustment of the

screen potential and bias. With the limited screen potential available in the receiver, this adjustment resulted in a rather low screen potential applied to the red gun with consequent degraded focus and aggravated highlight blooming.

It has been found that brighter and sharper pictures can be produced if all of the screens are maintained at approximately the same potential (260-280 volts) and unequal video drives are provided. The following ratio of drives has been found experimentally to give results which appear to be close to the optimum: green = 1; red = 1.3; and blue = 1.

It has also been found that this arrangement makes it easier to obtain similar effective gammas in the three guns and thus produce a step wedge having uniform color balance throughout the steps.

**BEATNOTE BETWEEN SOUND AND COLOR SUBCARRIER**

Care must be taken to minimize overload in the circuits which precede the second detector, as it would introduce intermodulation. The most important intermodulation is that between the sound and chrominance subcarriers, which produces a

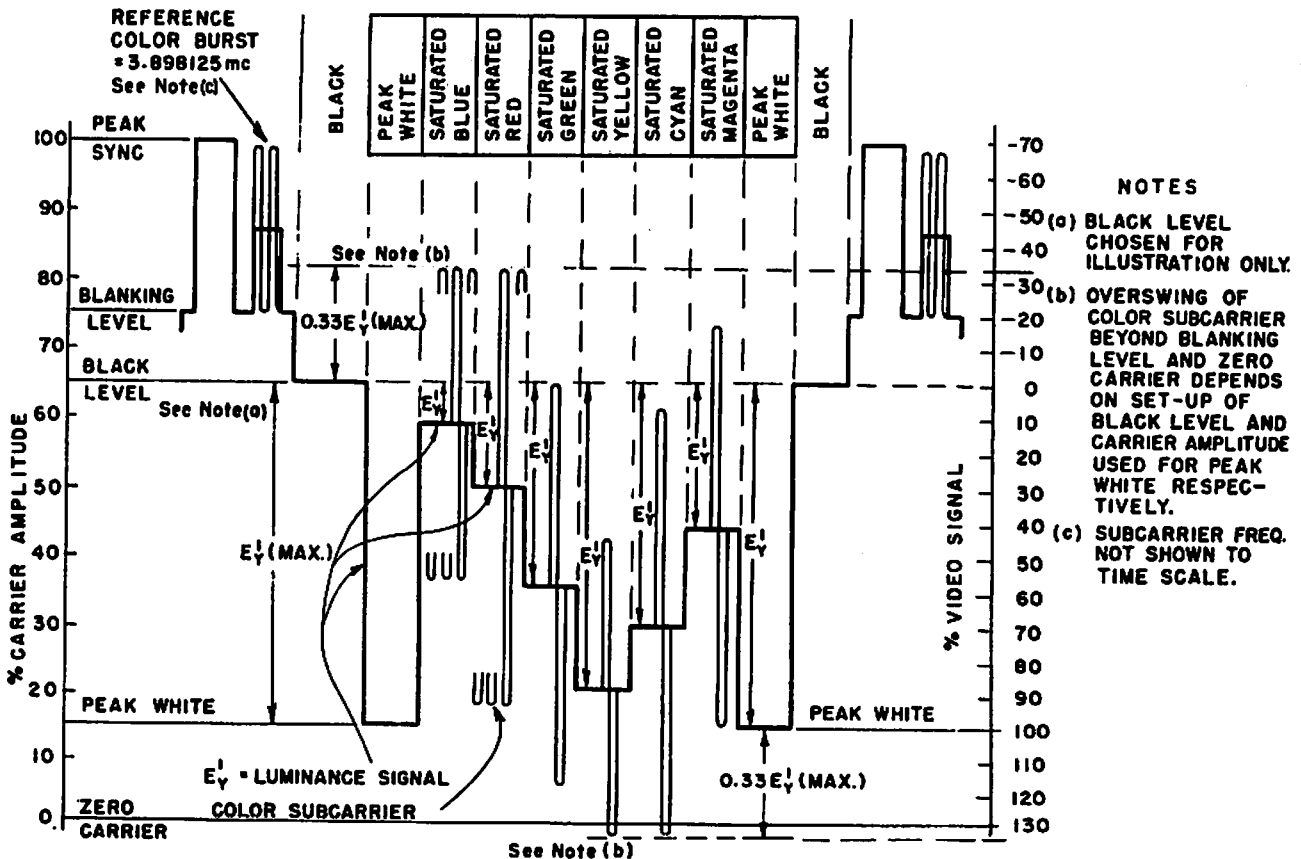

Fig. 2 - Time and Amplitude Characteristics of Complete Color Signal

600 kc beatnote ( $4.50 - 3.9 = 0.6$  Mc) appearing as brightness bars in the picture. The visibility of the beatnote is reduced by separating the unmodulated sound and color subcarriers by an odd harmonic of half line-frequency ( $77 \times 15.734 (+)/2$  kc). \* However, since the sound is transmitted by FM, this preferred separation holds only for silent periods.

The generation of this beatnote in the second detector, or after, can be minimized by largely attenuating the sound carrier in the IF amplifier. It has been determined experimentally that the amplitude of the beatnote is reduced to an unobjectionable amount if the sum of the attenuations of the chrominance subcarrier and the sound carrier, relative to the picture carrier, is 40 db or greater. While this can be done in a split-sound receiver, intercarrier sets require that the sound carrier be attenuated not more than 20 to 26 db relative to the picture carrier. Fig. 4 shows how it is

possible to obtain the operating advantages of inter-carrier-sound receivers by providing a separate last IF sound stage and separate second detectors for the sound and picture channels so as to permit a large attenuation of the sound carrier prior to the application of the picture signal to the picture detector. Both the picture and sound carriers are amplified in the last sound-channel IF stage before application to the sound-channel second detector where the 4.5 Mc sound carrier is produced.

CONTRAST CONTROL

The contrast control is located ahead of the chrominance-signal takeoff point in the video section of the receiver, so that changing the contrast control will not require resetting the saturation control.

A type of contrast control commonly used in black-and-white receivers is a variable cathode resistor which serves to vary both bias and degeneration in the controlled stage. Because of unavoidable stray capacitances such a control introduces a variable amount of high boost which depends on both the setting of the control and the effective transconductance of the tube. With such an ar-

\* To obtain this preferred separation, it is now expected that the color subcarrier will be located at 3,894,230 cycles instead of 3,898,125 cycles; the new value makes the line frequency  $3,894,230 (2/495) = 15,734(+)$  cycles.

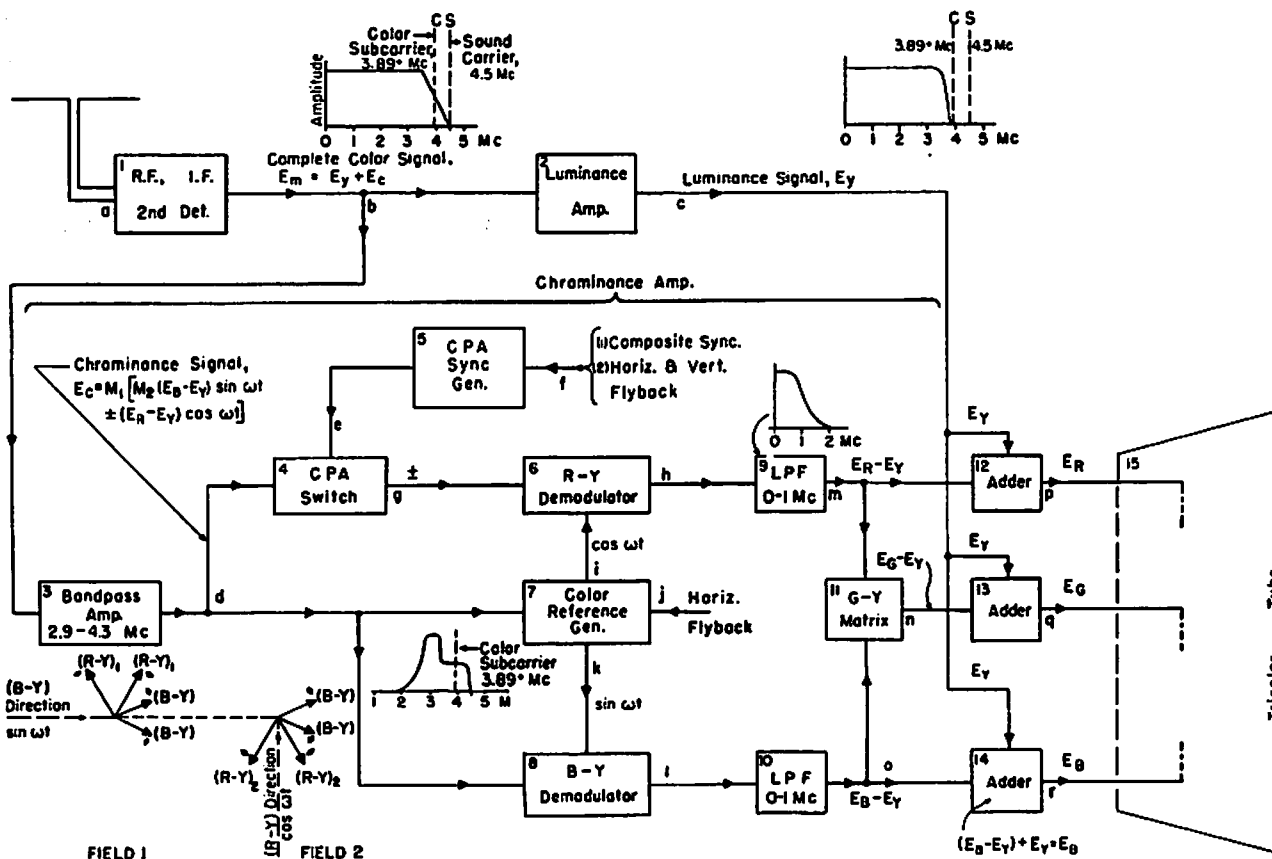

Fig. 3 - Block Diagram of a Color Receiver

range high-amplitude luminance components at the grid of the controlled stage, which change its effective transconductance, will change both its input reactance and its high-frequency transmission characteristics. This produces errors in the phase of the chrominance signal which depend on the luminance, and the magnitude of this effect depends on the position of the control. There is no compensating shift in the reference burst because it is transmitted at a constant level which is independent of luminance. A type of control which does not have this defect has been used in some developmental color receivers and consists of a low-impedance potentiometer which can be driven by a high-impedance plate-driver stage.

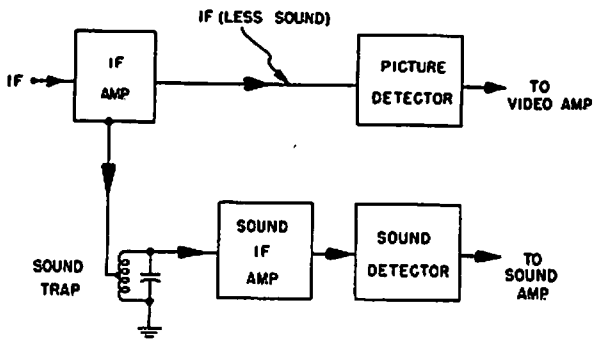

Fig. 4 - Use of Separate Sound and Picture Detectors to Reduce Beatnote Between Sound and Chrominance Subcarriers

Note on circuits shown in this paper:

The circuits shown in this paper to illustrate the principles discussed do not necessarily incorporate all of the recommended practices. They are chosen for clarity and actual practical experience. Thus the luminance circuit of Fig. 5

and the associated color decoder of Fig. 13 make use of direct coupling, whose lack of flexibility to changes we mention, and of equal video drives for the tricolor tube, which is not recommended.

LUMINANCE AMPLIFIER

A typical luminance amplifier is shown in Fig. 5.

The RF and IF amplifiers should be broad enough to pass the complete color television signal without unduly attenuating the chrominance sub-carrier and its sidebands while providing the desirable 6 db attenuation of the picture carrier. The luminance signal determines the geometrical resolution of the picture. Its bandwidth is governed by several compromises. Attenuation of the color subcarrier (3.9 Mc) and adjacent frequencies in the luminance channel should be high enough to prevent the latter from being overly visible since frequency interleaving reduces this visibility only partly. In the circuit of Fig. 5 this is accomplished by means of the 3.9 Mc trap.

Increased picture sharpness can be obtained by means of a rising frequency characteristic (after the color subcarrier take-off) resulting in a 6 to 10 db boost at 2 to 3 Mc, which compensates for the apparently large spot size of presently available color picture tubes. This is accomplished by the RC circuit in the cathode of the video stage in Fig. 5.

Since the components of the chrominance signal are limited in bandwidth in the chrominance channel, and therefore are delayed in time, the luminance signal must be similarly delayed to insure time coincidence at the picture tube.

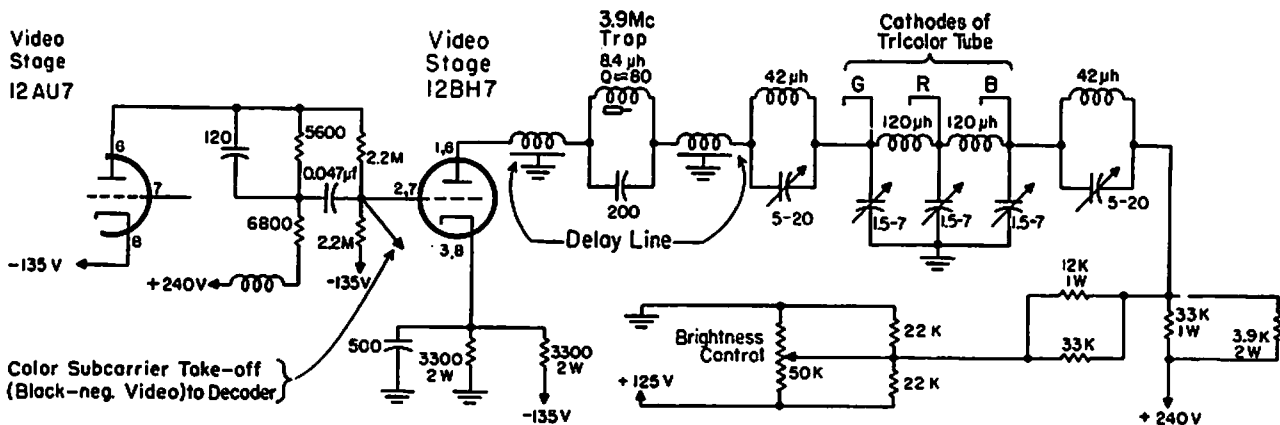

Notes: 1- The two triodes of the 12BH7 are used in parallel. 2- Resistors are 1/2-watt unless stated otherwise. 3- M=10<sup>3</sup> K=10<sup>3</sup> µ=10<sup>-6</sup>

Fig. 5 - Luminance Channel of Receiver for Equal Video Drives and Direct Coupling (See also associated chrominance channel in Fig. 13.)

delay (0.5 - 1.2  $\mu$ s) can be provided by means of a delay line. In Fig. 5 this delay line is in two parts located on each side of the 3.9 Mc color-subcarrier trap. The filter sections which follow the delay line help to provide proper resistive termination to signals along the delay line. The signals to the cathodes of the three guns of the CRT are isolated from each other by filter sections, which have a delay of approximately 0.06  $\mu$ s each; these sections separate the cathode capacitances and thus provide better high-frequency response.

**CHROMINANCE CHANNEL**

The chrominance channel is the heart of the color receiver. It extracts the coloring information from the complete color signal and resolves it into its color-difference components ( $E_R-E_Y$ ,  $E_B-E_Y$ , and  $E_G-E_Y$ ) so that, after combination with the luminance signal  $E_Y$ , they may be impressed on the three guns of the color tube as  $E_R$ ,  $E_B$ , and  $E_G$ .

The upper sideband of the chrominance signal is limited to about 400 kc above the color subcarrier by the need for its complete attenuation at the sound-carrier frequency of 4.5 Mc. The lower sideband can extend as far below the color subcarrier as it is desired to transmit color bandwidth.

However, unless balanced demodulators are used, the lower sideband should not extend below the highest frequency in the output of the color demodulator as otherwise some of the luminance signal frequencies may find themselves in the output of the demodulator, because they cannot be separated by selective circuits. Moreover, the chrominance bandwidth is usually limited to about 1 Mc below the color subcarrier at 3.9 Mc so as to filter out the low-frequency high-energy components (0 - 2.9 Mc) of the luminance signal from the synchronous demodulator where they would produce annoying beatnotes.

For these reasons the pass band of the chrominance channel of color receivers usually extends from about 2.9 Mc to about 4.3 Mc.

**NATURE OF CHROMINANCE SIGNAL**

The two independent color-difference signals,  $E_R-E_Y$  and  $E_B-E_Y$ , are individually modulated on components of the color subcarrier which are in quadrature ( $\sin \omega t$  and  $\cos \omega t$ ), as shown by the following equation:

$$E_{CH} = M_1 M_2 (E_B - E_Y) \sin \omega t + M_1 (E_R - E_Y) \cos \omega t. \quad (5)$$

The color-difference signals are recovered by two synchronous demodulators. They can be kept sepa-

rate if the chrominance signal is received with sidebands which are symmetrical, in amplitude and phase, about the respective quadrature component ( $\sin \omega t$  or  $\cos \omega t$ ) of the color subcarrier; otherwise color contamination results.

**COLOR CONTAMINATION DUE TO QUADRATURE CROSSTALK**

This can be shown as follows: If one of the quadrature components of the subcarrier (such as the one which carries the  $E_R-E_Y$  modulation and whose in-phase direction is  $\cos \omega t$ ) consists of pairs of sidebands which have unequal amplitudes or are unsymmetrically disposed about the in-phase direction, it can be resolved into two sets of pairs of sidebands. The pairs of each set have equal amplitudes. One set is symmetrically disposed about the in-phase direction, in this case  $\cos \omega t$ , and the other set is symmetrically disposed about the quadrature direction, in this case  $\sin \omega t$  which carries the  $E_B-E_Y$  modulation. In other words the  $E_R-E_Y$  modulation crosstalks into the  $E_B-E_Y$  channel. The waveform of the envelopes of the in-phase and of the quadrature crosstalk components of the color subcarrier depends on the form of the pass band, as shown in Figs. 6 and 7.<sup>3</sup> Here the waveforms of the desired in-phase video

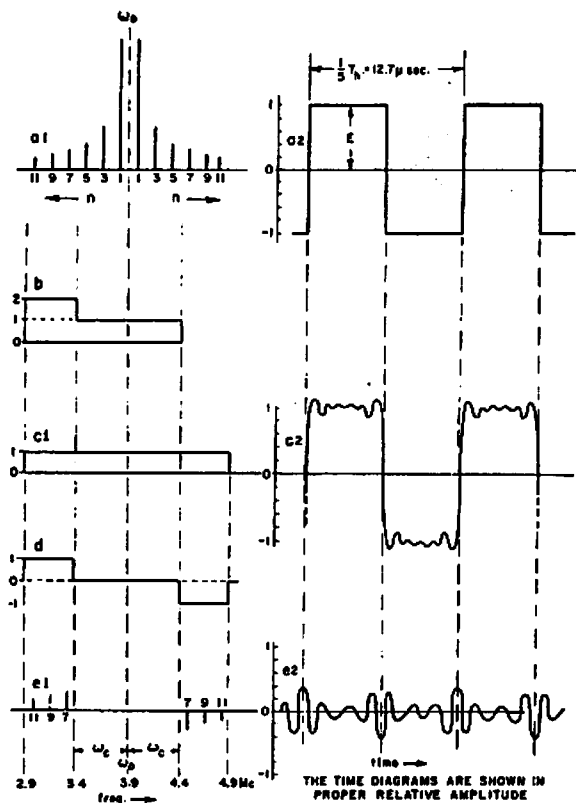

Fig. 6. - Waveforms of Quadrature Crosstalk for Case of Flat Characteristic at Color Subcarrier

frequency signal and of the unwanted quadrature crosstalk are indicated. It should be noticed that the waveform of the video crosstalk caused by sidebands of unequal amplitude, but no phase distortion (Figs. 6e2 and 7c2) is symmetrical about the time of initiation of the in-phase transient (Figs. 6c2 and 7b2). In other words, it resembles an odd derivative of the envelope of the in-phase component. Crosstalk whose waveform has skew-symmetry about the time of initiation, i. e., which resembles an even derivative of the in-phase component is caused by phase distortion.

In the NTSC signal, the  $E_R-E_Y$  component is larger than the  $E_B-E_Y$  component, so that the crosstalk from  $E_R-E_Y$  into  $E_B-E_Y$  is more important than the inverse. Assuming the pass band of Fig. 6b, where the upper sideband extends to 0.5 Mc and the lower sideband to 1.0 Mc from the color subcarrier, the crosstalk is produced by the single-sideband components from -0.5 Mc to -1.0 Mc. It results in color contamination along steep edges.

**REDUCTION OF QUADRATURE CROSSTALK**

The pass band of the chrominance signal should be shaped so as to minimize this crosstalk.

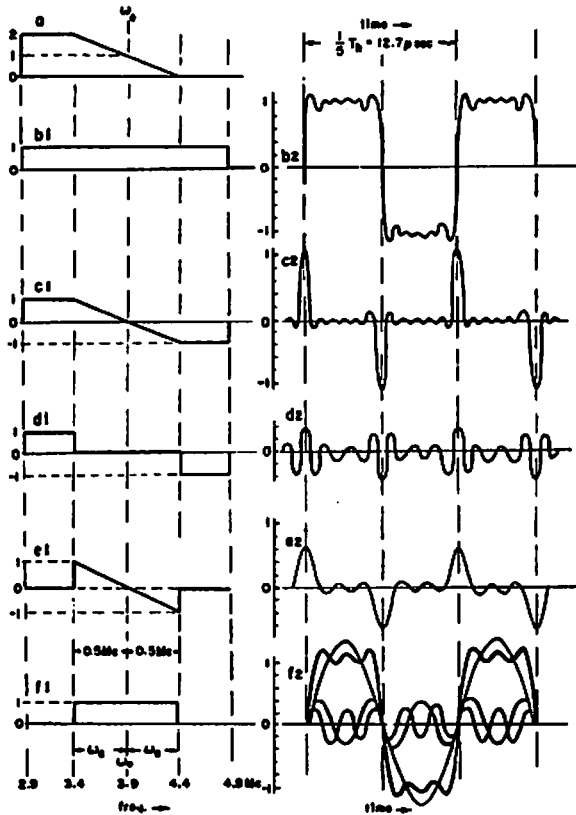

Fig. 7 - Same as Fig. 6 but for Sloping Characteristic at Color Subcarrier

The sloping pass band of Fig. 7a results in highly peaked crosstalk having a high amplitude but a very short duration, as shown in Fig. 7c2. In comparison the flat pass band of Fig. 6b is of lower amplitude (40%) but produces ringing for a somewhat longer time, as shown in Figs. 6e2 and 7d2. According to our experience, the waveform produced by the flat pass band of Fig. 6b is considerably less visible than that produced by Fig. 7a.

The chrominance pass band of Fig. 6b can be closely approximated by the combination of Fig. 8, where solid and dash lines show ideal and actual pass bands respectively. In this diagram Fig. 8a shows the antenna-to-second detector pass band. Except for the usual 6 db attenuation at the main picture carrier, it is flat from low video frequencies up to 3.4 Mc and then drops off linearly to zero at about 4.5 Mc, with the color subcarrier at 3.9 Mc down 6 db from the flat. The chrominance signal then is impressed on a bandpass filter whose characteristic, shown in Fig. 8b, can be obtained from two loosely coupled circuits with a high and a low Q respectively. The pass bands of Figs. 8a and 8b combine to give the overall desired chrominance characteristic shown in Fig. 8c.

The crosstalk may be eliminated from the output of the B-Y synchronous detector by a low-pass output filter with a 0.5 Mc cutoff or by changing the pass band to the input of the B-Y detector so as to be double-sideband for 500 kc and have no single-sideband transmission. The cost in performance is, of course, reduction in the pass band of the B-Y component.

The use of CPA permits the transmission of wide-band color because it allows single-sideband

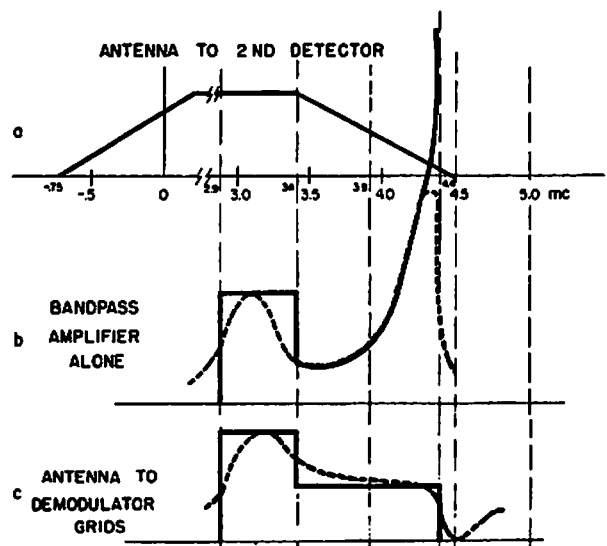

Fig. 8 - Practical Approximation to Characteristic of Fig. 6b

transmission by visually cancelling the color contamination on adjacent lines, which would otherwise be produced. If the crosstalk is minimized by suitable shaping of the chrominance pass band, as in Fig. 6 for example, CPA will not introduce any appreciable flicker on normal picture material. More detailed discussion of CPA is given later.

### SYNCHRONOUS DETECTORS

The two modulations,  $E_R-E_Y$  and  $E_B-E_Y$ , of the chrominance signal are recovered by two synchronous detectors. A synchronous detector functions by means of the principle of zero-beat heterodyning, which is illustrated in Fig. 9. An input signal  $E(t)\sin \omega t$  is applied to one grid of a multigrid tube such as 6AS6. A second signal having the same frequency, but which may differ in phase,  $2 \sin(\omega t + \Theta)$ , is applied to another grid. The plate current is proportional to the product of two voltages and is

$$i_p = 2 KE(t) \sin \omega t \sin(\omega t + \Theta). \quad (6)$$

The product of the two sines here gives

$$i_p = 2 KE(t) \left[ \frac{1}{2} \cos \Theta - \frac{1}{2} \cos(2\omega t + \Theta) \right]. \quad (7)$$

The double-frequency term,  $KE \cos(2\omega t + \Theta)$ , is filtered out by the low-pass filter in the plate of the modulator which passes only

$$i_p = KE(t) \cos \Theta. \quad (8)$$

In other words the output of the demodulator is proportional to the input-signal amplitude multiplied by the cosine of the phase angle ( $\Theta$ ) between the color subcarrier and the heterodyning (reference) signal. The plate current is therefore proportional to the component of the color subcarrier phasor along the reference direction. Referring to Equation (1), the two components of the chrominance signal  $E_R-E_Y$  and  $E_B-E_Y$  modulate two components of the subcarrier which are in quadrature. The color-difference signals,  $E_R-E_Y$  and  $E_B-E_Y$  can therefore be separated by heterodyning the chrominance signal in one case by a signal having the phase of the subcarrier component on which  $E_R-E_Y$  is modulated (i.e.  $\cos \omega t$ ) and in the other case by a signal having the phase of the subcarrier component on which  $E_B-E_Y$  is modulated (i.e.  $\sin \omega t$ ). This is shown in Fig. 10.

The green color-difference signal  $E_G-E_Y$  may be recovered by combining  $E_R-E_Y$  and  $E_B-E_Y$  in the proportions given in equation (4) and reversing the polarity of the result. The circuit which does this is called a matrix.

### COLOR SYNC

The hue at any point in the picture is a function of the instantaneous phase of the chrominance subcarrier with respect to a reference signal related to R-Y. This phase-reference signal is transmitted by means of a burst of unmodulated subcarrier (i.e., 3.9 Mc) following the horizontal sync pulse as shown in Fig. 2. This unmodulated subcarrier is used to establish CW reference signals of the same frequency and related phase for application to the synchronous demodulators. The burst should preferably go through all the selective circuits preceding the input to the demodulator so that it will undergo the same phase shifts as the chrominance signal referenced to it.

Since the burst lasts only for a small part (4%) of the total time, it should be gated to exclude the noise occurring when there is no burst. The gate should close before the onset of the video signal as the latter, especially its chrominance component, can introduce large phase errors because of its high amplitude. The gate should not close so early as to exclude close-in echoes of the burst which arrive before the video signal. These echoes may have any amplitude and phase in relation to the burst and, when added to the latter, determine the reference phase for the large picture areas which follow as their chrominance depends on the sum of the direct and indirect signals. Even in the absence of echoes, the gate should not exclude part of the burst as this might cut out a phase shift, occurring at the lagging edge of the burst, which compensates for a phase shift of opposite polarity which may occur at the leading edge. These two opposing phase shifts may occur because the upper and lower sidebands of the burst (which is a pulse-modulated subcarrier) may be attenuated differently. Unequal sidebands result in a quadrature component whose polarity at the lagging edge of the burst is opposite to its polarity at the leading edge, as shown previously in Figs. 6 and 7. The long-time-constant circuits of the phase detector average these errors to zero.

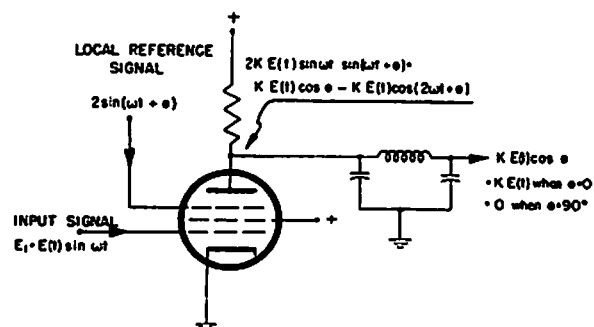

Fig. 9 - Principle of Synchronous Demodulation

The tolerance on gate opening is less severe as the components of the horizontal sync near 3.9 Mc are very weak. The horizontal flyback provides a convenient source of gating voltage. If it is used for this purpose, its own phase stability should be high enough to insure that the gate closes at the proper time.

Integrating circuits, which convert the burst to the CW color reference signal, are usually of one or the other of two types. One of these is a driven high-Q circuit tuned to the burst frequency. Signal-to-noise considerations indicate the desirability of a high-quality crystal filter ( $Q \approx 25,000$ ) which will, in addition, insure against excessive drift. This type of integrator has the additional

advantage that there is no CW color reference signal generated by the receiver when there is no burst present, as in black-and-white reception. However, such a sharply tuned circuit requires automatic retuning to eliminate the static phase shift which it introduces when it is tuned off-frequency. Or a fixed-tuned crystal can be followed by a phase shifter controlled by the output of a phase detector which measures the phase shift caused by the crystal. This type is shown in Fig. 11a.

The other type of integrator depends on the automatic-phase-control (APC) of a locally generated oscillation (see Fig. 11b). In this case the APC loop consists of a phase detector, a frequency

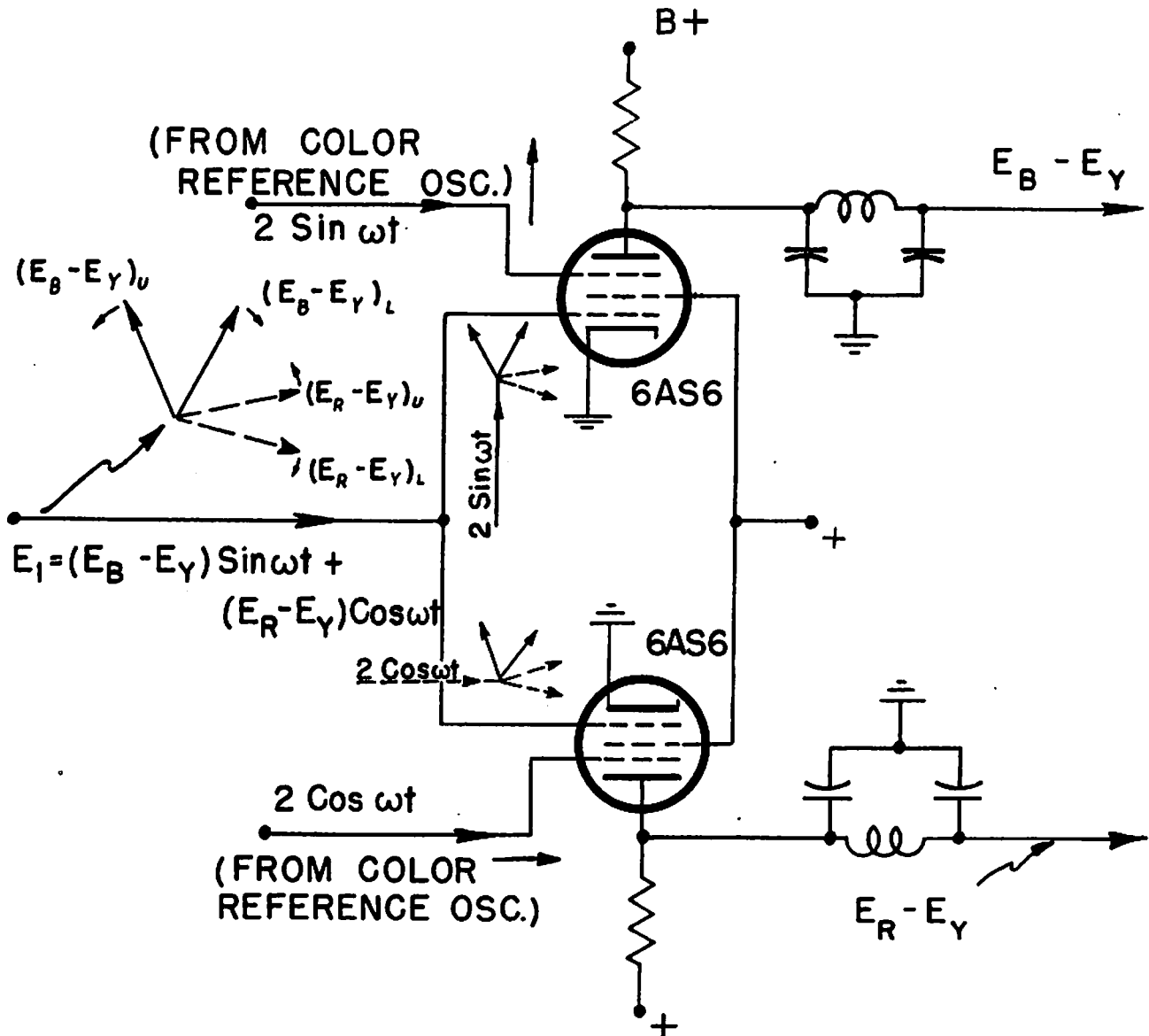

Fig. 10 - Quadrature Demodulation

selective filter which determines the loop response, a reactance tube, and the local oscillator. The filter should have a high ratio of DC to AC gain, so that rapid pull-in may be achieved over a wide range of frequencies, together with tight static phase, and narrow noise bandwidth. The local color oscillator should have a high order of stability and might even be crystal-controlled to insure good long-term and short-term stability.

The CW output of either type of integrator is then applied to the color demodulators after suitable phase splitting to obtain the desired quadrature relation.

### COLOR PHASE ALTERNATION (CPA)

At the time of going to press, it appears likely that the frequency of the color subcarrier will be lowered from 3.89 Mc to 3.58 Mc. This will provide an additional 0.3 Mc for the upper sideband of the chrominance signal. In addition, the chrominance signal may be reportioned to take advantage of the two color vision for medium size detail which has been recently reported. The resultant reduction of quadrature crosstalk and the more efficient Mc of the eye's characteristic may reduce the advantages of CPA to the point of making it unnecessary. The following discussion is on the basis of the NTSC signal specified in October 1951 and in use at this time.

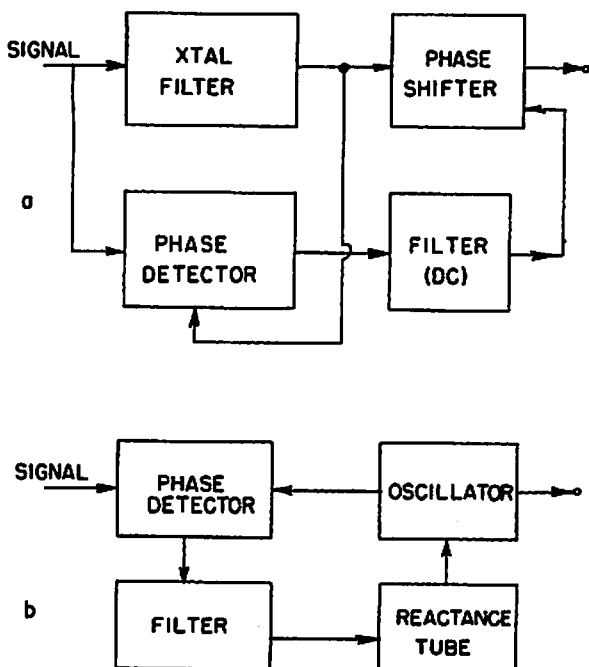

Fig. 11 - Practical Integrators for Color Reference Signal

Color phase alternation (CPA) minimizes large-area color contamination due to misphasing of the color carrier reference. This misphasing may result from inadequate phase control at the receiver, malfunction of the receiver, or multipath effects. By increasing the tolerance to misphasing, CPA reduces the cost of phase control and, even with tight phase control, increases the probability of obtaining good pictures under multipath conditions.

The use of CPA also minimizes small-area color contamination due to asymmetry in amplitude or phase characteristics about the color subcarrier, which would occur in the absence of CPA. This asymmetry may be caused by (1) mistuning of the local oscillator (by the receiver station-selecting tuner), (2) drift of circuit elements, and (3) multipath. By increasing the tolerance to asymmetry, CPA reduces the cost of circuit elements, inspection, and maintenance.

By allowing asymmetry, CPA permits much wider chrominance bandwidth than the 0.4 Mc to which it would otherwise be limited with a subcarrier at 3.9 Mc. This greater bandwidth is available for use at the option of the set designer and raises the performance ceiling of the system.

By permitting a high value of subcarrier frequency, CPA increases the allowable luminance bandwidth of color receivers and increases the compatibility of monochrome receivers because the color subcarrier is at a frequency where the transmission is low.

The advantages of CPA described in the foregoing paragraphs are offset by certain disadvantages. Because of constant-luminance failure, CPA may introduce flicker in both large and small areas of highly saturated colors. This flicker decreases rapidly with desaturation, such as exists in the large majority of color scenes. It can be made completely negligible by one or more of the following steps: (1) Improvement in constant-luminance operation; (2) Proper design of color receivers, such as making the pass band flat at the color subcarrier frequency; (3) Tighter phase control at the receiver; and (4) Good balance of the CPA circuit. If these precautions are taken, the flicker will be negligible for all scenes occurring in nature up to a luminance level exceeding 60 foot-lamberts.

The use of CPA may increase the cost and complexity of receivers. This disadvantage is believed to be unreal because CPA introduces compensating tolerances which result in economies in manufacture, testing, and maintenance.

**OPTIMUM LOCATION OF CPA RESTORING CIRCUIT IN RECEIVER**

The polarity of the R-Y component of the transmitted chrominance signal alternates on successive fields so that the receiver R-Y demodulator must reverse its output in synchronism with this alternation. This may be accomplished by reversing (1) the signal input to the R-Y demodulator, or (2) the heterodyning reference signal ( $\cos \omega t$ ),

or (3) the demodulator output on successive fields,  $E_R - E_y$ .

The third possibility may be dismissed immediately because it involves switching low-frequency signals at a low-frequency rate (30 cycle), which makes it difficult to eliminate the switching transients from the desired video.

Let us now consider the second scheme. If the reference signal is reversed and its two polar-

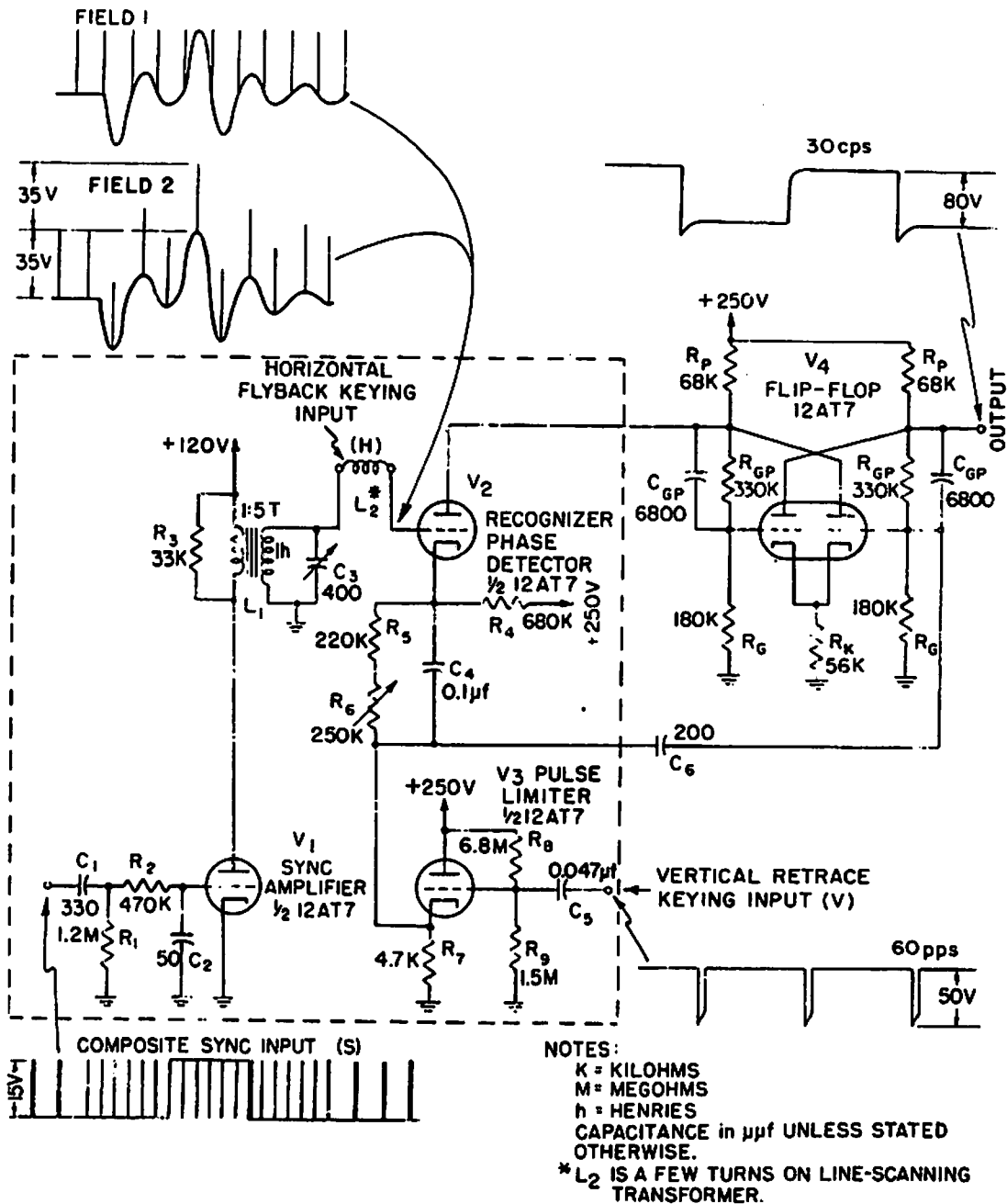

Fig. 12 - Field Recognition Circuit for Color Phase Alternation

ities are unbalanced in amplitude flicker will result in the gray parts, as well as in the colored areas, of color pictures as the unbalance introduces a 30 cycle pedestal in the output of the demodulator.

Turning to the first method, in which the chrominance signal is switched, flicker can occur only when the amplitude of the chrominance signal is large, that is on bright and highly saturated colors. The CPA switching occurs during vertical blanking when the chrominance signal is zero. Therefore, switching this signal can cause no transients. Switching the reference color signal, as in the second method, can introduce transients which can brighten part of the vertical retrace.

Leakage of either phase of the reference oscillator between the two demodulators should be minimized. This reference voltage can appear on the modulator signal grid (see Fig. 10) because of interelectrode and stray capacitances. If the input grids of the two modulators are connected directly, the reference oscillator phase intended for one demodulator can appear on the other. This leakage can be more economically reduced if the CPA switch is located in the input circuit of the R-Y demodulator, where it can act as a buffer as well, and thus prevent the R-Y demodulator reference voltage from backing into the B-Y demodulator. A second buffer may be used in the grid circuit of the second demodulator, or the capacitance between grids 1 and 3 of the demodulator tube may be neutralized by means of a coil which is parallel-resonant with the distributed capacitance and thus converts the feedback path from a capacitive reactance to a high impedance. (An example of this may be seen below in Fig. 13, where a 500 microhenry coil is provided for this purpose in the input circuit of V-8, and B-Y demodulator.)

For these reasons it is preferable to switch the chrominance subcarrier, the first of the three methods considered.

#### CPA SYNCHRONIZATION AND SWITCHING

The CPA switching at the transmitter is such that the subcarrier phasor representing  $E_R-E_Y$  leads the phasor representing  $E_B-E_Y$  during the field following the vertical sync pulse shown in diagram (1) of Appendix I of the "FCC Standards of Good Engineering Practice Concerning Television Broadcasting Stations" and lags during the field following the vertical sync pulse shown in diagram (2). These two fields are generally called "Field 1" and "Field 2" respectively. The stationary CPA axis coincides with the  $E_B-E_Y$  phasor.

At the receiver these two fields can be distinguished from each other by the fact that the relation between the leading edge of the vertical sync

pulse and the horizontal sync pulses prior to Field 1 differs by half of a line period from that prior to Field 2.

This difference between the two fields may be recognized by a circuit such as is shown in Fig. 12. The vertical sync pulse excites through amplifier  $V_1$  a circuit consisting of  $L_1$  and  $C_3$  which rings with a period equal to twice the line period. During Field 1, the horizontal sync pulses occur at the zero intercepts of the ringing oscillation. During Field 2 they occur at the peaks. This relation is shown in the waveforms at the upper left corner of Fig. 12, where the narrow vertical lines represent voltages derived from horizontal flyback (inserted by  $L_2$ ), which are closely related in time to the horizontal sync. If a suitable value of voltage obtained from horizontal flyback is added, as shown, to one from the ringing oscillation, the sum will exceed a specified threshold value for Field 2 only. The circuit is so adjusted that this threshold value just overcomes the cutoff bias of amplifier  $V_2$ , whose output then triggers the switching multivibrator-amplifier  $V_4$ .

Since the vertical pulse has a duration of three lines, the ringing caused by its lagging edge reinforces that produced by its leading edge so that the strongest trigger occurs during the back porch of the vertical pulse. This permits the recognizer tube to be gated by the field retrace to increase its immunity to noise. One requirement for optimum performance is that cleanly stripped vertical sync be available through  $V_1$  to trigger the ringing circuit.

The CPA reversal of the chrominance signal is performed by the multivibrator  $V_4$ , acting as a triggered self-switching amplifier. It switches two signals, which are identical except for opposite polarities, existing alternately between its two plates. The gain to the two plates must be properly balanced.

#### TYPICAL DECODER

Fig. 13 shows a decoder which was used in an early Hazeltine color receiver having direct-coupled video and equal drives of the tricolor tube. It is used with the luminance amplifier of Fig. 5.

The color synchronizing system is of the automatic-phase-control type and consists of tubes V-1, V-2, V-3, V-4, and V-5. A gating pulse, obtained from the yoke, keys-on amplifier V-2 during the color burst. This burst is obtained from the bandpass amplifier V-6, which also supplies the chrominance subcarrier to the two demodulators V-8 and V-9. The color reference voltage, obtained from buffer tube V-5, is split into the in-phase and quadrature components by the "Quadrature Transformer."

The frequency characteristic of the bandpass amplifier is determined by the tuned circuits in its input and output. The R-Y demodulator is supplied with signals of opposite polarities on successive fields from the center-tapped transformer in the plate circuit of the bandpass amplifier V-6. The two polarities are alternated by the CPA switching amplifier and multivibrator V-7, whose operation has been previously described. The CPA switch is balanced by the control in the cathode of V-7. Field recognition for CPA is supplied by tube V-12 and the associated transformer which is tuned to half of the line frequency. The threshold amplifier V-12B is keyed on by vertical flyback through tube V-13.

The green color-difference signal G-Y is obtained from R-Y and B-Y through the matrix amplifier consisting of V-10 and V-11.

#### OPERATING AND ADJUSTABLE CONTROLS FOR COLOR RECEIVERS

The controls required for a color receiver may be divided into three groups. The main operating controls are available as knobs on the front panel for the customer's use. In this class a color receiver should probably include a saturation control, in addition to the usual black-and-white controls.

The second group of controls are those which are normally adjusted at the time of installation and should be accessible from the front panel. These may include color hold and color phase. This group may also include the controls associated with the operation of the tricolor tube, i. e. those for static and dynamic convergence and color purity, as well as individual controls for screen and grid-bias potentials.

The third group of controls are those normally set as factory adjustments and located at the rear of the receiver. In a color receiver these

may include CPA bias level, CPA amplitude balance, B-Y differential gain, and color phase if not included in the first group.

#### BIBLIOGRAPHY

- 1 Report of Panel Actions, NTSC Panel 13 document P-13-162, October 23, 1952.
- 2 "Principles of NTSC Compatible Color Television" by C. J. Hirsch, W. F. Bailey, and B. D. Loughlin, Electronics, February 1952, pp. 88-95.
- 3 "Quadrature Crosstalk in NTSC Color Television and Reduction of its Visibility by Color Phase Alternation," by W. F. Bailey and C. J. Hirsch, NTSC Panel 12 document P-12-229, March 21, 1952; the subject was also discussed on pages 10-14 of Hazeltine Corporation Report No. 7132 entitled "Principles of NTSC Compatible Color Television".
- 4 "Frame Synchronization for Color Television" by D. Richman, Electronics, October 1952, pp. 146-150.
- 5 "Recent Improvement in Band-Shared Simultaneous Color Television," by B. D. Loughlin, Proc. I. R. E., October 1951, pp. 1264-1279.

#### HAZELTINE CORPORATION

  
Charles J. Hirsch  
Chief Engineer  
Research Division

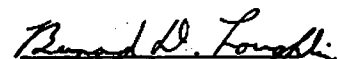
  
Bernard D. Loughlin  
Supervising Engineer

  
Charles E. Dean  
Editor

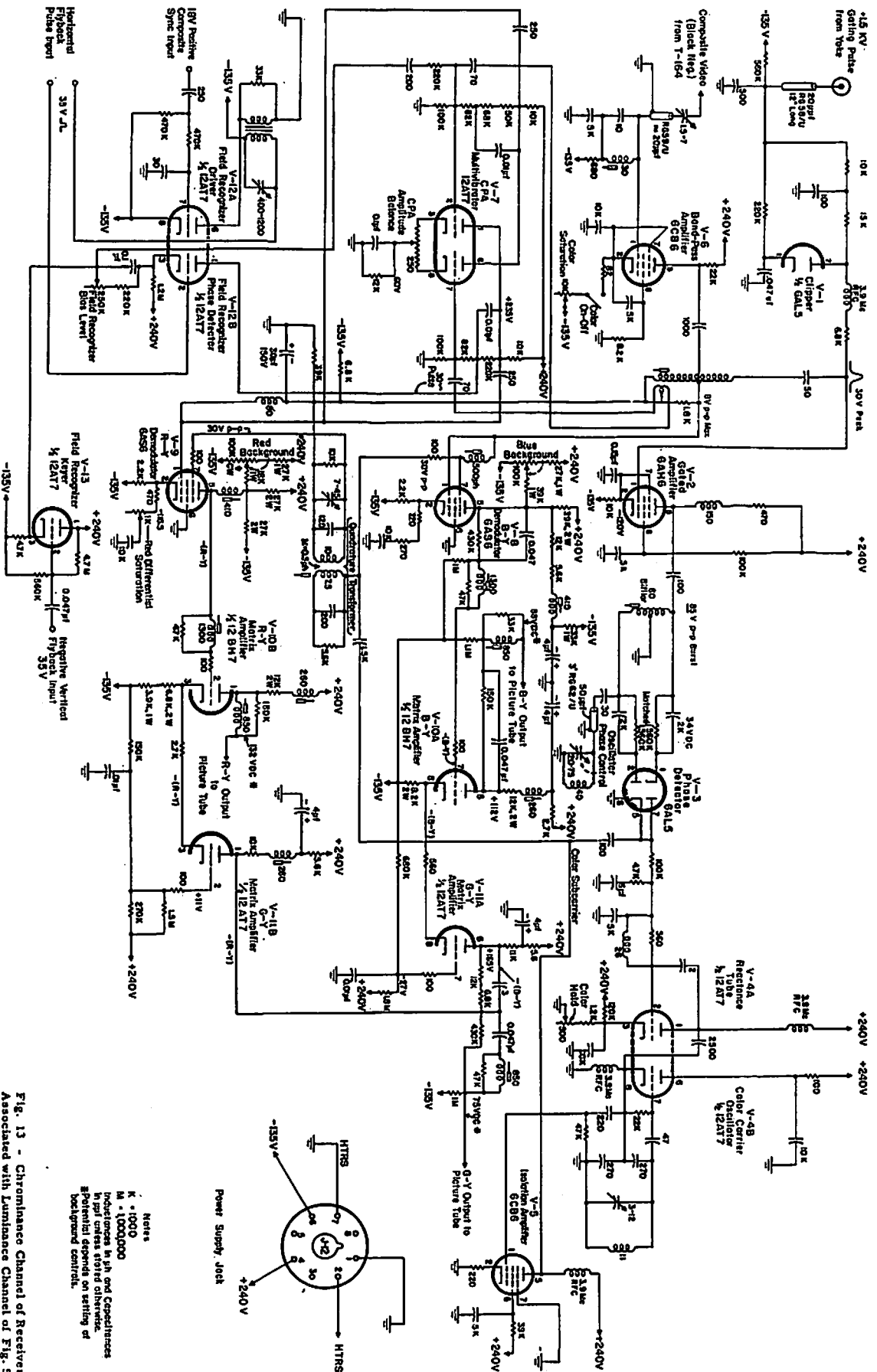

Fig. 13 - Chrominance Channel of Receiver Associated with Luminance Channel of Fig. 5

- Notes
- K = 1000
  - M = 1000000
  - Inductances in  $\mu$ h and Capacitances in pF unless noted otherwise.
  - Potential depends on setting of background control.