

Simpson

INSTRUMENTS THAT STAY ACCURATE

OPERATOR'S MANUAL

MODEL 406 CHROMATIC AMPLIFIER

SIMPSON ELECTRIC COMPANY

5200 W. Kinzie St., Chicago 44, Illinois, ES 9-1121

In Canada, Bach-Simpson, Ltd., London, Ontario

MODEL 406 CHROMATIC AMPLIFIER

GENERAL

The Simpson Model 406 Chromatic Amplifier provides an important filter-amplifying function at video frequencies for servicing the signal circuits of color-television receivers. The unit also finds useful application in checking of video circuits in monochrome television receivers.

A gain of 30 is developed by the Chromatic Amplifier, over a band of 4 Mc; the output is flat within ± 0.5 db from 3 kc to 4 Mc. The input impedance is high, and the output impedance is approximately 220 ohms.

APPLICATIONS



FIG. 1. TEST SET-UP FOR CHECKING FLATNESS OF VIDEO SWEEP OUTPUT FROM THE Chromatic Probe. IN THIS APPLICATION, THE Chromatic Amplifier OPERATES ALSO AS A FILTER.

The test set-up shown in Fig. 1 is very useful to check the flatness of the video sweep from the Chromatic Probe. Details of Chromatic Probe operation and use are contained in the instruction book for the probe. If the sweep is flat, the swept trace appears as shown in Fig. 2. If the swept trace is not flat within $\pm 5\%$, there is some fault in the equipment arrangement, which

should be corrected before proceeding with service tests. In this test, it should be noted that the unit is operating both as an amplifier and as a video-frequency filter. The tuning dials of the FM generator and the AM generator in the Model 480 Genescope, or Model 479, may be set to any corresponding frequency in the test, such as 25 Mc, 40 Mc, 160 Mc, etc.

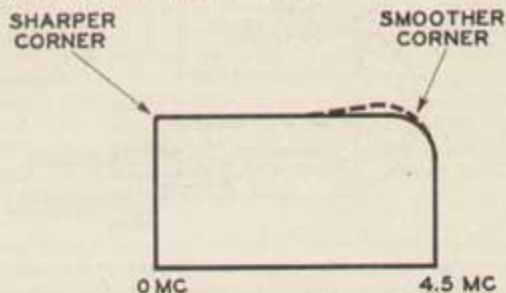

FIG. 2. APPEARANCE OF SWEEP TRACE, WHEN OUTPUT FROM Chromatic Probe IS FLAT. THERE MAY BE A SLIGHT HIGH-FREQUENCY RISE, AS INDICATED BY THE DOTTED LINE, NOT EXCEEDING 1 DB.

Fig. 2 shows a somewhat similar test set-up, which is used to check the flatness of the swept output from the Chromatic Probe, when loaded by the input circuit of the receiver under test. As before, the Chromatic Amplifier operates as a filter as well as an amplifier in this test. There should be no variation from flatness in the swept trace when this test is made. If there is excessive capacitance across the input circuit of the receiver under test, the high frequencies will be attenuated. Under normal conditions, the capacitance will not be sufficiently large to attenuate the high-frequency response to any appreciable extent. However, if an incorrect test point is selected for application of the sweep

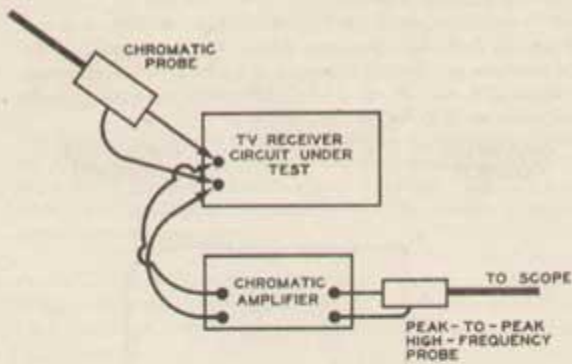

FIG. 3. USE OF THE Chromatic Amplifier TO TEST THE FLATNESS OF THE SWEEP OUTPUT FROM THE Chromatic Probe WHEN LOADED BY THE INPUT CIRCUIT OF THE RECEIVER UNDER TEST. AMPLITUDE OF RESPONSE IS LESS THAN IN FIG. 1, BECAUSE OF LOWERED LOAD IMPEDANCE SEEN BY THE CHROMATIC PROBE.

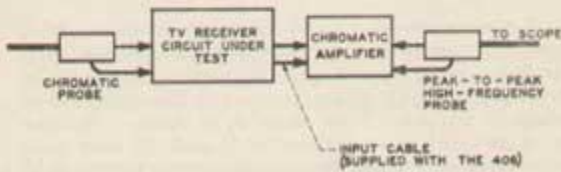

FIG. 4. TYPICAL ARRANGEMENT OF Chromatic Probe, Chromatic Amplifier, AND Peak-To-Peak High-Frequency Probe IN TESTING A LOW-GAIN COLOR-TV VIDEO-FREQUENCY CIRCUIT.

4

voltage, this difficulty may be encountered in a normally operating receiver.

After it has been determined that the swept input voltage to the receiver is flat, the Chromatic Amplifier may be connected as shown in Fig. 4 to observe the response of a video-frequency circuit in the receiver under test. In many tests, the use of the Chromatic Amplifier is not necessary, but in the testing of some low-gain circuits in color-TV chassis, its use will be found necessary. Typical low-gain circuits are the chroma amplifier, and the I demodulator circuits. The Y amplifier is also a low-gain amplifier, but is infrequently checked by sweep methods because of the strong ringing of the delay line.

When a very low-resistance load is shunted across the Chromatic Probe, it may sometimes be observed that the high frequency response tends to rise somewhat when checking the flatness of the swept input voltage. In such case, the high-frequency response can be flattened out by inserting a small series resistance, such as 100 ohms or more, between the output of the Chromatic Probe and the input of the receiver circuit under test. The test shown in Fig. 3 will indicate accurately when the value of the series resistor is correct. In rare instances, it may be found that the nature of the load on the Chromatic Probe is such that the low-frequency response tends to rise; in such case, a series capacitor of suitable value will serve to flatten out the low-frequency response.

A shielded input cable is provided with the Model 406, which is suitable for connection to all low-impedance points in a color-TV chassis. In some cases, it may be necessary to connect the 406 to a high-impedance point, and in such case, it is necessary to dispense with the shielded input cable, and to use a pair of open test leads to avoid high-frequency attenuation.

5

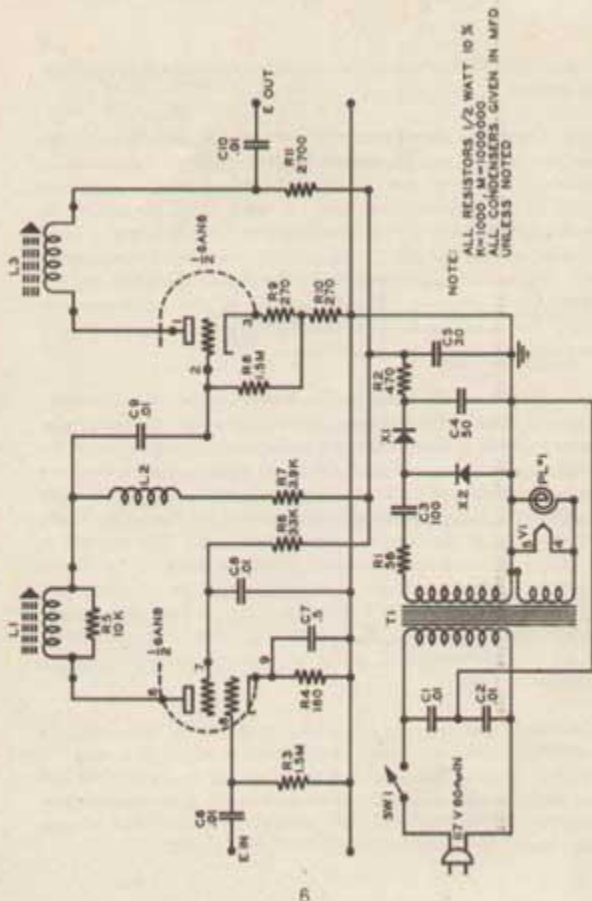

FIG. 5. SCHEMATIC DIAGRAM OF MODEL 406 CHROMATIC AMPLIFIER

MAINTENANCE

Under normal conditions, the Chromatic Amplifier requires no maintenance. However, after extended service, it is possible that the 6AN8 tube may become weak and require replacement. The circuit is non-critical, and a selected tube does not need to be used. A voltage-doubler circuit is used, (see Fig. 5) which develops a plate-supply voltage of approximately 250 volts. Low plate-supply voltage may result from aging of the electrolytic capacitors, or the selenium rectifiers. The frequency characteristic of the pentode section depends substantially upon the value of the plate-load resistor (nominally 3900 ohms), and if the high-frequency response becomes abnormally high or low, the value of this resistor should be checked.

7

