

MODELS T-64, 509, 510

GENERAL

- * Picture Area CIRCLE 64 square inches
- NORMAL 56 square inches
- Tubes Twenty-one plus two rectifiers
- Speaker 6-1/2 inch E.M. (85-ohm field)
- Speaker V.C. Impedance 3.2 ohms
- Antenna Provision for external antenna using 300-ohm transmission line.
- Tuning Pushbutton plus manual trimming adjustment.
- Tuning Range Twelve pre-set channels.

Channel No.	Freq. (mc)	Channel No.	Freq. (mc)
2	54-60	8	180-186
3	60-66	9	186-192
4	66-72	10	192-198
5	72-78	11	198-204
6	82-88	12	204-210
7	174-180	13	210-216

- Intermediate Frequency 26.25 mc
- Picture carrier 21.75 mc
- Sound carrier 4.5 mc
- Inter-carrier sound system
- Power Supply 105-125 V. 60 cycles AC
- Power Consumption 230 Watts
- Model Differences
- Model T-64 - Custom installation (chassis unit)
- Model 509 - Wood cabinet
- Model 510 - Plastic cabinet

CARE OF THE KINESCOPE WINDOW

The window in front of the picture tube is made of safety glass, hence may be cleaned by any of the conventional window cleaning processes. Abrasive or strong solvent type cleaning solutions that may scratch the glass or damage the cabinet finish, however, should be avoided.

HIGH VOLTAGE WARNING

Operation of the receiver chassis outside of the cabinet involves a shock hazard. An interlock in the line cord disconnects the power when the back cover is removed. The HIGH VOLTAGE supply, while of low current capacity, operates at a 9,000 volt potential. Exercise all normal HIGH VOLTAGE precautions while working with this equipment.

KINESCOPE HANDLING PRECAUTIONS

The kinescope housing provides adequate protection against possible tube implosion while in the cabinet. Do not expose the kinescope or handle it in any way without providing personal protection in the form of shatterproof goggles and heavy gloves. The kinescope should be handled by qualified personnel only.

The kinescope envelope encloses a high vacuum and with the large surface area of glass involved, the stresses set up particularly at the front rim of the tube, are considerable. Any abnormal handling stress, accidental blow at a highly stressed surface, or even a scratch on the surface of the tube could cause it to implode or collapse with destructive violence.

NON-OPERATING CONTROL ADJUSTMENTS

The "non-operating" or "screw-driver" adjustments normally will require an occasional minor adjustment if any circuit work or tube changing is required. A test pattern, generated either locally in the shop or obtained from a television station is recommended for best results. Normal picture contrast and brightness should be maintained during the following adjustments for best results.

Note that the following adjustments are made with the NORMAL/CIRCLE switch set at NORMAL.

HORIZONTAL-OSC.,-DRIVE,-LINEARITY,-CENTERING AND WIDTH ADJUSTMENTS

1. Advance the HORIZONTAL DRIVE control (clockwise) as far as possible without causing crowding of the right hand side of the test pattern or producing picture instability. Insufficient horizontal drive will cause the raster to fall short of filling the mask horizontally. Should the HORIZONTAL HOLD control fail to hold the test pattern in the normal manner, set the HORIZONTAL HOLD control in the middle of its range and adjust the HORIZONTAL OSC. A.D.I. screw for horizontal sync. (See Fig. 11 for location).

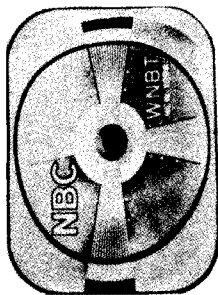

FIGURE 3.
WIDTH CONTROL MISADJUSTMENT

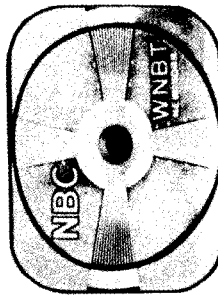

FIGURE 4.
HORIZONTAL CENTERING CONTROL MISADJUSTMENT

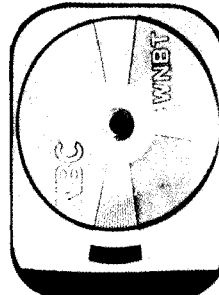

FIGURE 5.
HORIZONTAL LINEARITY CONTROL MISADJUSTMENT

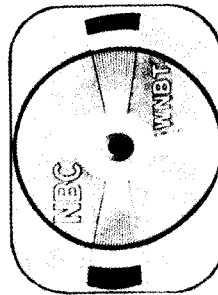

FIGURE 6.

2. Set the WIDTH and HORIZONTAL CENTERING controls so that the test pattern fits and centers in the horizontal dimension of the kinescope mask.

3. Set the HORIZONTAL LINEARITY control so that the test pattern is symmetrical from left to right. A slight readjustment of the HORIZONTAL DRIVE control may be necessary when making this adjustment.

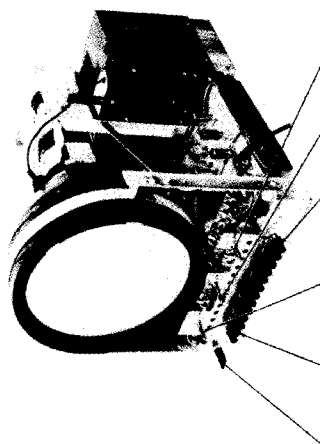

Fig. 2. Rear chassis view, location of non-operating controls.

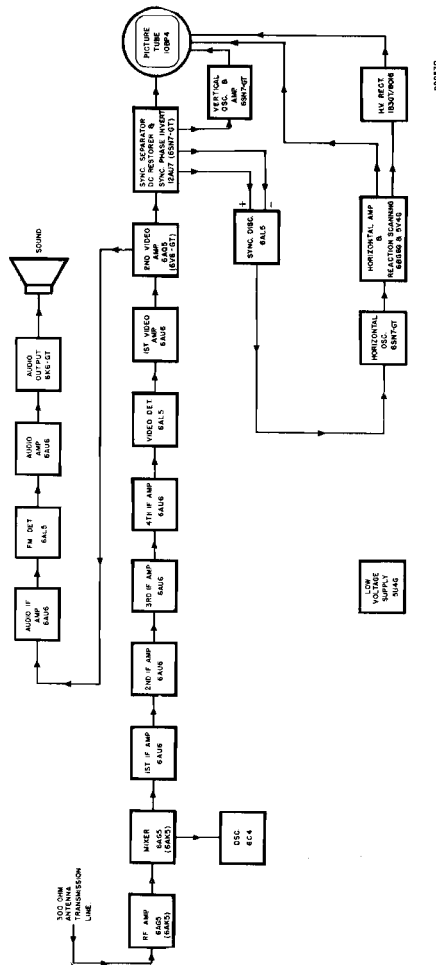

Fig. 1. Functional block diagram.

VERTICAL-CENTERING,-LINEARITY, AND HEIGHT ADJUSTMENTS

HEIGHT CONTROL MISADJUSTMENT

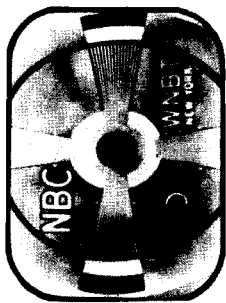

Figure 7.

VERTICAL CENTERING CONTROL MISADJUSTMENT

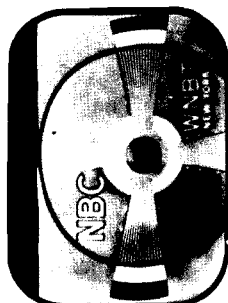

Figure 8.

VERTICAL LINEARITY CONTROL MISADJUSTMENT

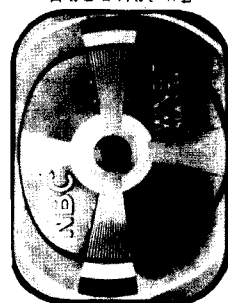

Figure 9.

Note - The sequence of "non-operating" control adjustments outlined above is suggested as a convenient method of approach and not an arbitrary procedure. Variations of the procedure is permitted to obtain the final result.

DISMANTLING FOR KINESCOPE REPLACEMENT OR ALIGNMENT ADJUSTMENTS

1. Remove the three front panel control knobs by pulling them straight from their shafts. The two dual control knobs must be removed in two pieces, removing the center unit first.
2. Remove the back cover. Note that the line cord and half of the interlock connector will come along with the back cover.

3. Disconnect the interconnecting cables and high voltage anode lead. (Snap-on connector).
4. Disconnect and remove the speaker to provide clearance for the kinescope tube mounting.
5. Release the two chassis units by removing the eight mounting screws at the base of the cabinet and pull the chassis clear of the cabinet. The KINESCOPE is now accessible for replacement or adjustment.

REMOVING THE KINESCOPE

Refer to the warning KINESCOPE HANDLING PRECAUTIONS. Follow the dismantling instructions above to expose the tube and proceed as follows:

1. Disconnect the KINESCOPE SOCKET at the base of the tube.
2. Remove the ION TRAP slipping it from the neck of the tube past the tube socket.
3. Measure the distance from the front face of the RUBBER BOOT to the front of the control plate. Keep this dimension handy for the installation of a new tube.
4. Loosen the steel band at the front rim of the tube and slip the tube with the RUBBER BOOT out through the steel band.

the distance from the front face of the RUBBER BOOT to the front of the control plate. Refer to the measurement made in step 3 above. If this dimension is off; loosen the two REAR SUPPORT MTG. screws, position the tube correctly and fasten the front rim firmly about the RUBBER BOOT.

3. The REAR SUPPORT must seat firmly against the flange of the tube and be securely anchored in place by the two REAR SUPPORT MTG. screws. Check the two SPRING CONTACTS grounding the outer coating of the kinescope tube. A high potential is developed on the outer coating of the tube if these contacts are faulty.

4. The DEFLECTION YOKE must seat firmly against the flange of the tube. Check by loosening the single DEFLECTION YOKE ADJ. screw and pushing the DEFLECTION YOKE housing forward as far as it will go. Take up on the mounting screw temporarily to hold the coil in place.

5. Slip the ION TRAP over the neck of the tube. If it is the ring type, the arrow points toward the front of the tube; if it is the clamp type, the blue coated clamp is toward the front.

6. Connect the tube socket and anode connector to the kinescope and turn on the receiver.

7. After allowing a few minutes for warm up, turn up the brightness control and set the ION TRAP for maximum raster brilliance, backing off the brightness control adjustment as the maximum point is approached. The ION TRAP must be rotated about the axis of the tube as well as shifted along the neck of the tube to obtain the proper setting. The arrow on the ring type ion trap will generally point at the HV anode connector when properly positioned as far as rotation is concerned, hence a rough setting may be obtained immediately with this type of trap.

With the BRIGHTNESS control set for slightly above average brilliance and the CONTRAST control full, counter-clockwise, adjust the FOCUS control until the line structure of the raster is clearly visible and readjust the ION TRAP for maximum raster brilliance. The final touches on this adjustment should be made with the brightness control at the maximum position with which good line focus can be maintained.

8. Set the HORIZONTAL and VERTICAL CENTERING controls at mid-position. If a corner of the raster is shadowed, it indicates that the electron beam is striking the neck of the tube. Loosen the FOCUS COIL ADJ. screws and rotate the coil about its vertical and horizontal axis until the entire raster is visible, approximately centered and with no shadowed corners. Tighten the adjustments with the coil in this position.

9. If the lines of the raster are not horizontal or square with the picture mask loosen the DEFLECTION YOKE ADJ. screw and rotate the DEFLECTION YOKE until this condition is obtained. Tighten the adjustment.

10. Follow the procedure under NON-OPERATING CONTROL ADJUSTMENTS and make any minor adjustments of the FOCUS COIL or DEFLECTION YOKE necessary to obtain the desired results. A slightly better average focus may be obtained by sliding the FOCUS COIL back and forth along the kinescope neck while adjusting the FOCUS control and watching the test pattern. The final adjustment of the focus coil should leave the raster approximately centered.

MEASUREMENT OF H.V. POTENTIAL ON KINESCOPE ANODE

The second anode potential will be approx. 9,000 V. on a receiver that is functioning properly. Since the high potential for the kinescope anode is obtained from the horizontal output transformer, the "non-operating" control adjustments outlined above must be made or be known to be in proper adjustment before the H.V. measurement will have any meaning. Improper operation of the horizontal sweep circuit or circuit faults in the high voltage filter will generally account for an abnormal anode potential. If the anode potential is low, check the HORIZONTAL DRIVE adjustment outlined above.

CAUTION HIGH VOLTAGE

Do not use hand held flexible test leads when making the following measurement. Keep the hands clear of the circuit during measurement. A 9,000 V. potential exists in this circuit. Exercise all normal high voltage precautions.

1. Connect a 50-megohm resistor string in series with a 200 microampere meter. Connect the free meter terminal to the chassis and the high side of the resistor string to the anode cap of the kinescope. The connection to the anode cap may be made with a fine wire slipped under the connector. Make up the resistor string with 10-megohm one or two watt resistors to provide a safety factor for voltage breakdown. If 10-megohm resistors are used, a total of five will be required to obtain the 50 megohms. Make the setup self-supporting and allow adequate clearance between the resistor string and chassis parts to prevent high voltage breakdown.

2. Turn on the receiver and set the BRIGHTNESS and CONTRAST controls at minimum. The microammeter will read approx. 180 microamperes or 9,000 V. at the kinescope anode. The anode potential is measured in this manner (CONTRAST and BRIGHTNESS controls at minimum; meter current approx. 200 microamperes) to simulate the kinescope load on the high voltage power supply.

ALIGNMENT PROCEDURE

Note - The following alignment adjustments do not require the use of the kinescope tube. It is recommended that the tube be removed if extensive alignment adjustments are to be made.

CAUTION - Removal of the kinescope tube exposes the HIGH VOLTAGE anode connector contact. Keep this lead and contact clear of personnel servicing equipment and grounded objects on the service bench. Exercise all normal high voltage precautions while working with the exposed units. See Figures 14 and 16 for high voltage points on the power supply chassis.

EQUIPMENT REQUIRED

- Signal generator covering 4 mc to 30 mc
- Signal generator covering 40 mc to 215 mc
- Electronic voltmeter
- Two 150-ohm carbon resistors
- One .01 mid. 600 V. tubular paper condenser

F-M SOUND CHANNEL ALIGNMENT

1. Connect the low frequency signal generator output between the control grid (pin 1) of the 6AU6 1st VIDEO AMP. tube (V-9) and chassis ground.
2. Connect the electronic voltmeter between pin 7 of the 6AL5 FM DET. tube (V-16) and chassis ground.
3. With the signal generator (unmodulated) set at 4.5 mc, set the 4.5 MC LIMITER GRID ADJ. and FM DET. PRI. ADJ. for maximum d-c voltage as measured by the electronic voltmeter. Adjust the limiter grid coil (L-14) before adjusting the I-m detector transformer (I-1) primary. Use just enough signal generator output to obtain approximately one volt at the electronic voltmeter.
4. Connect the electronic voltmeter across the 1,000 mfd condenser (C-17) at the output of the I-m detector stage and adjust the FM DET. SEC. ADJ. of the I-m detector transformer (T-1) for the null.
5. Shift the frequency of the signal generator either side of 4.5 mc and touch up the FM DET. PRI. ADJ. for approximately equal peaks. Use just enough signal generator output to obtain one volt peaks for best results.

I-F AMPLIFIER ALIGNMENT CHART

1. Connect the electronic voltmeter across the 5600-ohm resistor (R-37) in the plate circuit of the 6AL5 VIDEO DET. tube (V-8). This resistor is located on the terminal strip between the 6AU6 4th IF AMP. tube (V-7) and the 6AL5 VIDEO DET. tube (V-8).
2. Connect the output of the low frequency signal generator to the receiver's antenna input through two 150-ohm carbon resistors, one connected in each conductor of the transmission line.
3. Set the signal generator output (unmodulated) to develop two volts at the electronic voltmeter and adjust the five I-f

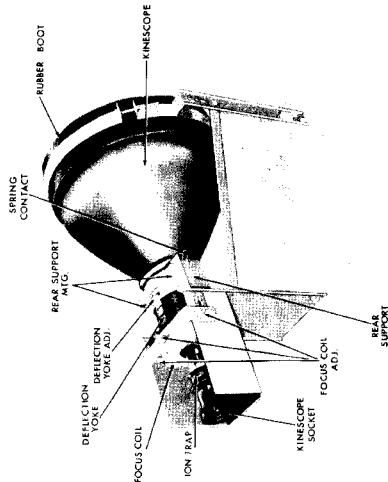

Fig. 10. Kinescope mounting detail.

INSTALLING THE KINESCOPE

1. Slip the RUBBER BOOT over the front rim of the kinescope and position the tube so that the anode contact is at the top and slightly to the right of the center as viewed from the screen of the tube.
2. Slip the tube through the front rim (socket first) and on through the REAR SUPPORT, DEFLECTION YOKE and FOCUS COIL and seat the tube firmly against the REAR SUPPORT. If the tube fails to slip into place smoothly, investigate and remove the cause of the trouble. Do not force the tube. Check

MODELS T64, 509, 510

4. Each channel may be aligned independently without affecting the alignment of the others. Alignment of the individual channels is carried out as follows:

- (a) Set the FINE TUNING control condenser in the center of its capacity range.
- (b) Press the channel button corresponding to the channel number to be aligned.
- (c) Set the "BFO" generator at 24.5 mc (No modulation).
- (d) Set the high frequency signal generator per the alignment chart. (No modulation).
- (e) Clip on a .01 mfd condenser between pin 2 of the

10BP4 kinescope (V-19) and pin 1 of the 6AU6 AUDIO AMP tube (V-17) and adjust the OSC. ADJ. trimmer corresponding to the channel being aligned for a rough audio beat note, using the speaker as a detector. The connection at pin 2 of the kinescope can be made at the terminal strip under the chassis provided for the socket leads of this tube.

(f) Disconnect the .01 mfd condenser, shut off the "BFO" signal generator, and adjust the MIXER ADJ. and RF AMP ADJ. trimmers for maximum d-c voltage as measured by the electronic voltmeter. Use just enough signal generator output to obtain approximately one volt at the electronic voltmeter. This completes the alignment of any one channel, and all others are to be treated in the same manner.

CHANNEL ALIGNMENT CHART

Channel No.	Channel Freq. (mc)	H.F. Signal Generator Freq. (No modulation)	Channel Freq. (mc)	H.F. Signal Generator Freq. (No modulation)
2	54-60	57 mc	180-186	183 mc
3	60-66	63 mc	186-192	189 mc
4	66-72	69 mc	192-198	195 mc
5	76-82	79 mc	198-204	201 mc
6	82-88	85 mc	204-210	207 mc
7	174-180	177 mc	210-216	213 mc

STATION CHANNEL ALIGNMENT

1. Due to the broad frequency response of the I-F amplifier, it is necessary to use a 24.5 mc signal generator or oscillator (unmodulated) as a beat frequency oscillator (BFO) in order to locate the center frequency of the I-F amplifier response for the correct local oscillator adjustment. This "BFO" generator should be loosely coupled by means of a wire from the generator output, placed in close proximity to the 6AL5 VIDEO DET. tube (V-8).

2. Connect the high frequency signal generator output to the receiver's antenna transmission line through the two 150-ohm carbon resistors, one connected in each conductor of the transmission line.

3. Connect the electronic voltmeter across resistor R-57 in the plate circuit of the 6AL5 VIDEO DET. tube (V-8) as for the I-F amplifier alignment.

amplifier coils, according to the following chart, for maximum d-c voltage as measured by the electronic voltmeter. Readjust the signal generator output as required to maintain the two volt potential at the electronic voltmeter.

I-F AMPLIFIER ALIGNMENT CHART

Signal Generator Frequency (No Modulation)	Adjustment (Refer to Fig. 11)	Stage Adjusted
26.2 mc	26.2 MC IF ADJ.	Mixer
23.5 mc	23.5 MC IF ADJ.	1st IF amp.
23.5 mc	23.5 MC IF ADJ.	2nd IF amp.
22.2 mc	22.2 MC IF ADJ.	3rd IF amp.
22.2 mc	22.2 MC IF ADJ.	Video detector

4. Set the signal generator at 26.2 mc. Reduce the signal generator output until the electronic voltmeter reads one volt and readjust the 26.2 MC IF ADJ. for maximum output voltage at the electronic voltmeter. Readjust signal generator output to maintain a one volt peak for this adjustment.

5. Check the I-F amplifier frequency response by tuning the signal generator from 21 mc through 26.25 mc and observing the change in d-c voltage at the electronic voltmeter. If the signal generator output is set for an electronic voltmeter reading of 1.5 volts at the peak I-F amplifier response, the d-c voltage should not drop below one volt between the two peaks normally obtained with this I-F amplifier. If the response is unsatisfactory, repeat steps 3 and 4 or try slight modifications of the recommended settings to obtain the desired response. Avoid retoning the coils with the iron core at the bottom end of the coil form. (Adjustment screw near limit of its travel.) Check the two carrier I-F responses, 21.75 mc and 26.25 mc. The 21.75 mc response will be approximately 20 db below the peak response (Approx. 0.15 volt) and the 26.25 mc response will fall approximately 8 db. below the peak (Approx. 0.4 volt). Refer to Fig. 12.

The average I-F amplifier sensitivity when feeding the signal generator output through the antenna input as described above will run approximately 600 to 3,000 microvolts for the one volt d-c peak measured across resistor R-57. (Receiver's oscillator operating on channel 6).

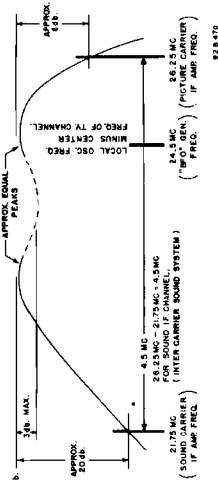

Fig. 12. I-F amplifier response.

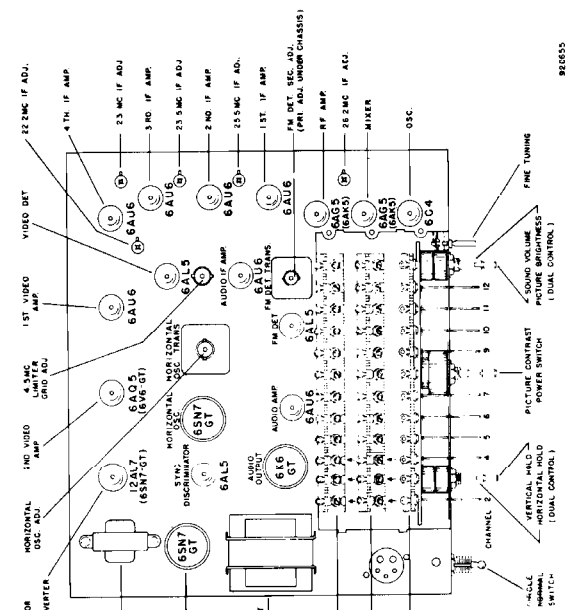

Fig. 11. Top view, alignment points.

The overall sensitivity for the receiver will run approximately 100 to 200 microvolts for one volt DC at resistor R-57 when measured in the above manner.

CARRIER vs I-F FREQUENCY CHART

Channel No.	Channel Freq. (mc)	Picture Carrier Freq. (mc)	Sound Carrier Freq. (mc)	Receiver Osc. Freq. (mc)	Picture IF Freq. (mc)	Sound IF Freq. (mc)	Picture IF less Sound IF (mc)
2	54-60	55.25	59.75	81.5	26.25	21.75	4.5
3	60-66	61.25	65.75	87.5	26.25	21.75	4.5
4	66-72	67.25	71.75	93.5	26.25	21.75	4.5
5	76-82	77.25	81.75	103.5	26.25	21.75	4.5
6	82-88	83.25	87.75	109.5	26.25	21.75	4.5
7	174-180	175.25	179.75	201.5	26.25	21.75	4.5
8	180-186	181.25	185.75	207.5	26.25	21.75	4.5
9	186-192	187.25	191.75	213.5	26.25	21.75	4.5
10	192-198	193.25	197.75	219.5	26.25	21.75	4.5
11	198-204	199.25	203.75	225.5	26.25	21.75	4.5
12	204-210	205.25	209.75	231.5	26.25	21.75	4.5
13	210-216	211.25	215.75	237.5	26.25	21.75	4.5

MODELS T64, 509, 510

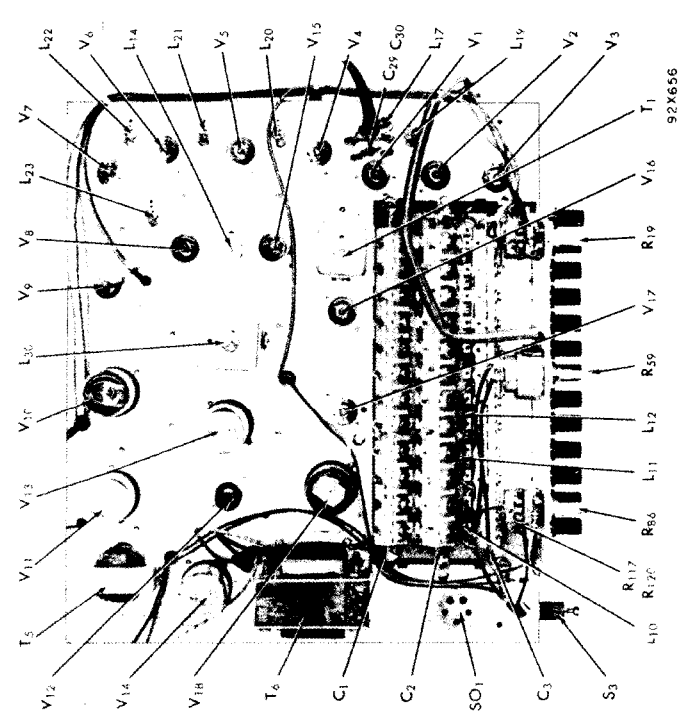

FIG. 13. Top view, receiver chassis, component location.

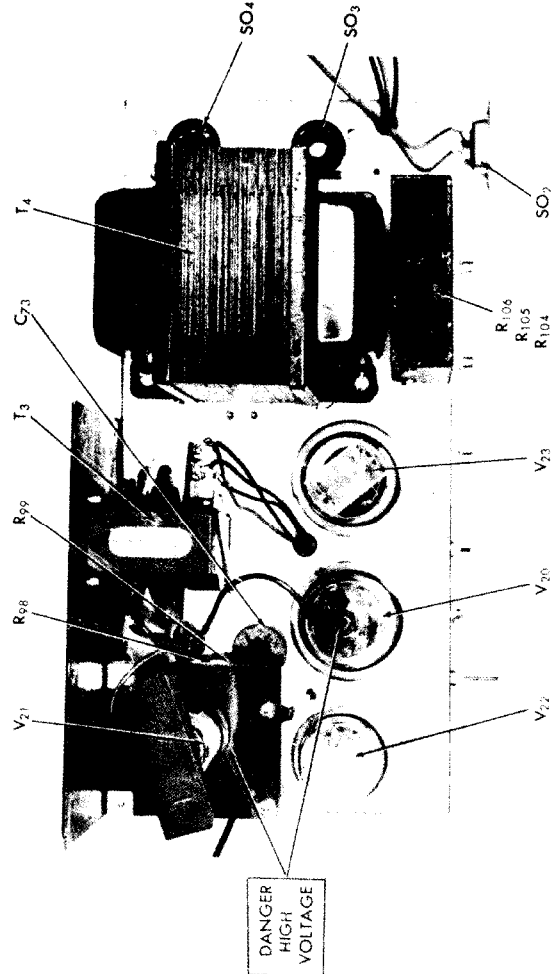

FIG. 14. Top view, power supply chassis, component location.

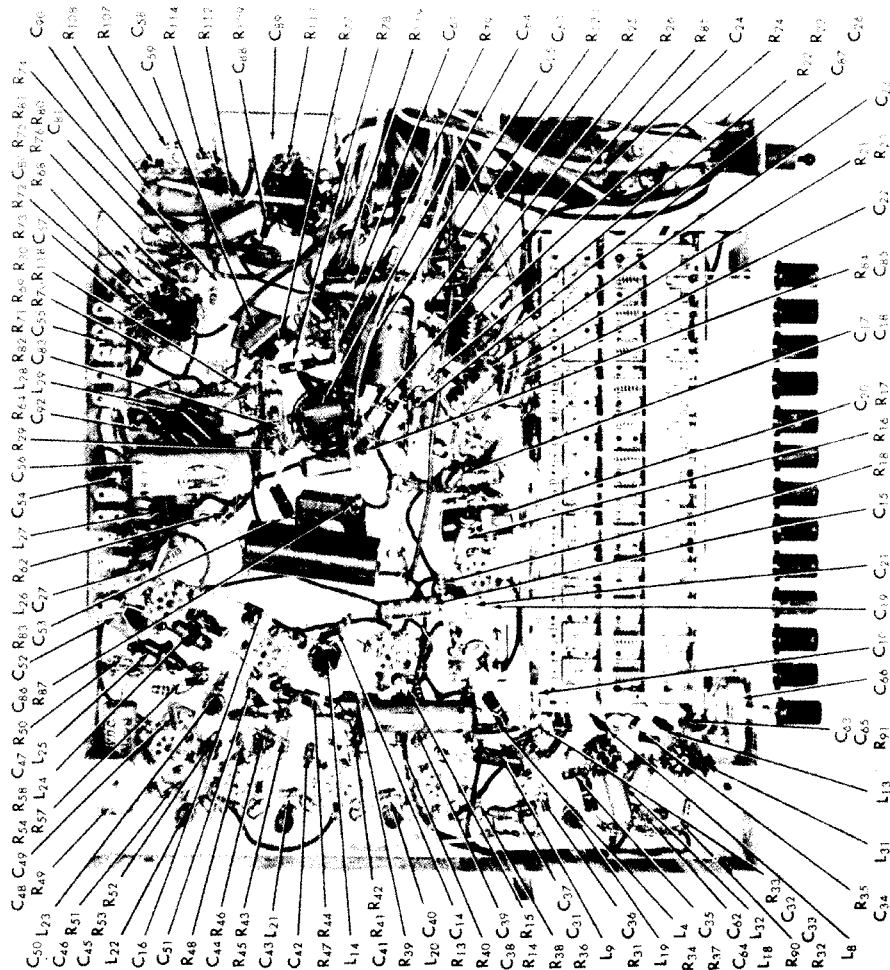

FIG. 15. Bottom view, receiver chassis, component location.

92X658

DANGER
HIGH
VOLTAGE

Ref. No.	Description	Hallcrafters Part Number
RESISTORS (Cont.)		
R-13	150,000 ohms 1/2 watt, carbon	RC20AE154K
R-14	12,000 ohms 1/2 watt, carbon	RC20AE123K
R-15,18	33,000 ohms 1/2 watt, carbon	RC20AE333K
R-16,17	10,000 ohms 1/2 watt, carbon	RC20AE103J
R-19	1 megohm/50,000 ohms, VOL-LINE/BRIGHTNESS control (dual)	25B737
R-20	330 ohms 1/2 watt, carbon	RC20AE331K
R-21	66,000 ohms 1 watt, carbon	RC30AE663K
R-22,113	2.2 megohms 1/2 watt, carbon	RC20AE225M
R-23,24,54,82	470,000 ohms 1/2 watt, carbon	RC20AE474K
R-25	660 ohms 1 watt, carbon	RC30AE661K
R-26	1000 ohms 1 watt, carbon	RC30AE102K
R-27,28	560 ohms 1/2 watt, carbon	RC20AE561K
R-29	160,000 ohms 1/2 watt, carbon	RC20AE164K
R-30,76	15,000 ohms 1/2 watt, carbon	RC20AE153K
R-31,32	150 ohms 1/2 watt, carbon	RC20AE151K
R-33	10,000 ohms 1/2 watt, carbon	RC20AE103K
R-34	15,000 ohms 1/2 watt, carbon	RC30AE153K
R-35,58,63,70,75	1 megohm 1/2 watt, carbon	RC20AE105M
R-36,39,44,47,77,78,92,106	100,000 ohms 1/2 watt, carbon	RC20AE104K
R-37	10,000 ohms 1 watt, carbon	RC30AE103K
R-38,91	22,000 ohms 1/2 watt, carbon	RC20AE223K
R-40,43,48	2500 ohms 1/2 watt, carbon	RC20AE222K
53,90	5600 ohms 1/2 watt, carbon	RC20AE562K
R-41,49,57,79	68 ohms 1/2 watt, carbon	RC20AE680K
R-42,46,51	8200 ohms 1/2 watt, carbon	RC20AE822K
R-45,52,80,81	220,000 ohms 1/2 watt, carbon	RC20AE244K
R-50	39,000 ohms 1 watt, carbon	
R-55	(Part of coil L24)	
R-56,61,65,66	1 megohm 1 watt, carbon (part of coils L25, 27, 28, and 29)	
R-59	2500 ohms, CONTRAST control (part of coil L26)	25B789
R-60	4700 ohms, 1 watt, carbon	
R-62	3300 ohms 1 watt, carbon	RC30AE332K
R-64	6700 ohms 1/2 watt, carbon	RC20AE672K
R-67	4700 ohms 2 watts, carbon	RC40AE472K
R-68,118	47,000 ohms 1/2 watt, carbon	RC20AE473K
R-69	27,000 ohms 1/2 watt, carbon	RC20AE273K
R-71,72,74	3600 ohms 1/2 watt, carbon	RC20AE362K
R-73,87	270,000 ohms 1/2 watt, carbon	RC20AE274K
R-83	6800 ohms 1/2 watt, carbon	RC20AE682K
R-84,97	1000 ohms 1/2 watt, carbon	RC20AE102K
R-85	50,000/1 megohms, HORIZONTAL, TAIL/VERTICAL control (dual)	RC20AE683K
R-86	47 ohms 1/2 watt, carbon	25B788
R-93	47 ohms 1/2 watt, carbon	RC20AE470K
R-94	56 ohms 1 watt, carbon	RC30AE560K
R-95	2200 ohms 2 watts, carbon	RC40AE222K
R-96	2200 ohms 2 watts, carbon	RC40AE221K
R-98	3.3 ohms 1/2 watt, carbon	RC20AE033M
R-99	1 megohm 2 watts, carbon	RC40-AE105-K
R-100	20 ohms 2 watts, HORIZONTAL CENTERING control	25B707
R-101	20 ohms 2 watts, VERTICAL CENTERING control	25B706
R-102	470 ohms 2 watts, carbon	RC40AE471K
R-103	2500 ohms 4 watts, FOCUS control	25B708
R-104	1000 ohms 20 watts, WW	24BH102D
R-105	1100 ohms 20 watts, WW	24BH112D
R-106	8200 ohms 10 watts, WW	24BG822E
R-107	6.8 megohms 1/2 watt, carbon	RC20AE685M

**DANGER
HIGH
VOLTAGE**

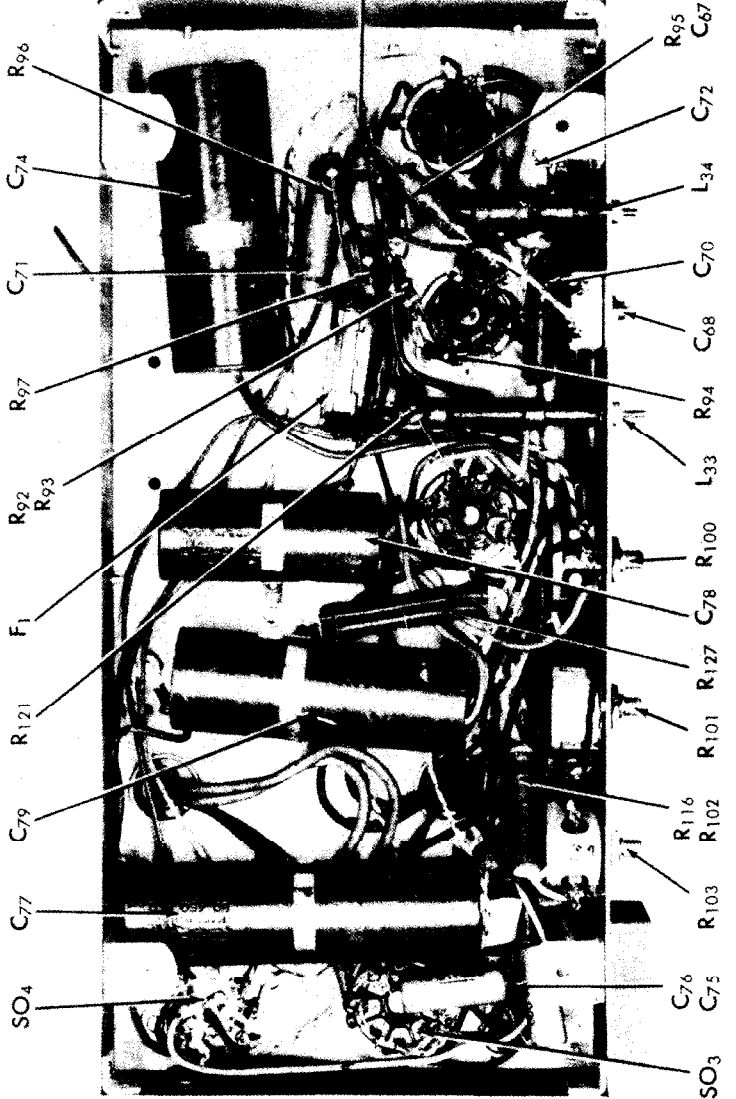

92X725

Fig. 16. Bottom view, power supply chassis, component location.

SERVICE PARTS LIST

Hallcrafters Part Number	Description	Component location
C-22,23,70,93	CONDENSERS	
C-24	500 mmf. 10,000 V., ceramic	46A Z 103J
C-25	40-40 mid. 450 V., electrolytic	45B135
C-26,92	.01 mid. 600 V., mounded paper	45A121
C-27	80 mid. 450 V., electrolytic	CM20A471M
C-28	250 mid. 10 V., 1000 mid.	46AU1041
C-34	6 V., electrolytic	47A160-1
C-38,48	30 mid. 250 V., electrolytic	46AT254J
C-49	.002 mid. 600 V., tubular	47A160-11
C-51	330 mmf. 500 V., mica	46AU5033J
C-52	6200 mmf. 500 V., mica	46AY5033J
C-53	220 mmf. 500 V., mica	46AY104J
C-54,57	4700 mmf. 500 V., mica	46AX254J
C-55,72,90	3300 ohms 1 watt, carbon	CM30A152K
C-56,89	(Part of coils L1,3,5, and 7)	46AY203J
C-58,59	2200 ohms 1 watt, carbon	46AZ502J
C-60,71	(Part of coils L2 and L6)	48A199
C-61,81,83,85	1 megohm 1/2 watt, carbon	
C-66	(Part of coils L4, 8 and 13)	
C-67	1 megohm 1/2 watt, carbon	47B20391K5
C-68	(Part of coils L10, 11 and 12)	44A361
C-20	5 mid. 50 V., electrolytic	45A109

MODELS T64, 509, 510

Hallcrafters' Part Number

Ref. No.	Description	Hallcrafters' Part Number
T-6	Transformer, vertical output	55C114
L-1,5	Coil, r-f amp. and mixer stages	51A1048
L-2	Coil, r-f amp. stage	51A1051
L-3	Coil, r-f amp. stage	51A1050
L-4	Coil, r-f amp. stage	51A1048
L-6	Coil, mixer stage	51A1047
L-7	Coil, mixer stage	51A1046
L-8,13	Coil, mixer and osc. stages	51A1041
L-9,31	Coil, r-f choke (Red color code)	53B008
L-10	Coil, osc. stage	51A1044
L-11	Coil, osc. stage	51A1043
L-12	Coil, osc. stage	51A1042
L-14	Coil, 4.5 mc. sound trap	51B1132
L-15	Coil, focus	51A1065
L-16	Coil, antenna	53B140
L-17	Coil, antenna	51A1039
L-18	Coil, r-f choke (Blue color code)	53A009
L-19,20,21,22,23	Coil, i-f amplifier	50A372-1
L-24	Coil, video peaking	51A1079
L-25	Coil, video peaking	51A1080
L-26	Coil, video peaking	51A1130
L-27	Coil, video peaking	51A1082
L-28	Coil, video peaking	51A1131
L-29	Coil, video peaking	51A1129
L-30	Coil, horizontal sweep osc.	50B411
L-32	Coil, heater choke (Tube V-3)	53A133
L-33	Coil, WIDTH control	51B1072
L-34	Coil, HORIZONTAL LINEARITY control	51B1071
*V-1,2	Type 6AG5; RF amp. and mixer	90X6AG5
V-3	Type 6C4; oscillator	90X6C4
V-4,5,6,7,9,15,17	Type 6AU6; 1st, 2nd, 3rd, 4th IF amp.; 1st video amp.; audio amp.; and audio amp. IF amp.; and audio amp.	90X6AU6
V-8,12,16	Type 6AL5; video det.; FM det.; and sync. disc.	90X6AL5
*V-10	Type 6AQ5; 2nd video amp. and sync. disc.	90X6AQ5
**V-11	Type 12AU7; sync. separator; DC restorer; and sync. phase inverter	90X12AU7
V-13,14	Type 6SN7GT; horizontal osc. and vertical osc. & amp.	90X6SN7GT
V-18	Type 6K6GT; audio output	90X6K6GT
V-19	Type 10BP4; kinescope	90X10BP4
V-20	Type 6BG6G; horizontal amp.	90X6BG6G
V-21	Type 1B3GT; high voltage rectifier	90X1B3GT
V-22	Type 5V4G; reaction scanning	90X5V4G
V-23	Type 5U4G; low voltage rectifier	90X5U4G
F-1	Fuse, 1/4 ampere, type 3AG	39A334

* Some sets use a type 6AK5 tube.
** Some sets use a type 6SN7GT tube.

PLUGS AND SOCKETS

Ref. No.	Description	Hallcrafters' Part Number
PL-1	Plug, speaker (Part of speaker ass'y)	10A300
PL-2	Plug, 10BP4 anode	87A1688
PL-3	Line cord and plug PL-4	10A239
PL-5	Plug, 8 prong (Power)	69A077
PL-6	Shell, plug (Used on PL-5)	10A299
PL-7	Plug, 9 prong (Power)	10A299
	Shell, plug (Used on PL-6)	10A324
	Plug, 2 prong (Focus coil)	10A301

TUBES, RECTIFIERS AND FUSES

Ref. No.	Description	Hallcrafters' Part Number
41X12103	Channel selector ass y complete (Includes PB switch, trimmers, coils, etc.)	41X12103
85C079	Speaker assembly (Includes connector PL-1)	85C079
16B138	Rubber strip, kinescope mounting (Model T-64)	16B138
16E137	Rubber boot, kinescope mounting (Models 509 & 510)	16E137
76D406	Clamp, kinescope mounting	76D406
67C860	Bracket, kinescope clamp support	67C860
67B885	Bracket, rear kinescope support	67B885
67C869	Bracket, focus coil housing	67C869
69A094	Shield, tube (V-18)	69A094
18A134	Insert, rubber (Focus coil)	18A134
21B083-2	Ion trap	21B083-2
8B823	Plate, bakelite (Mtg. for tube V-21)	8B823
22D249	Glass, safety (clear) (Model 509)	22D249
7D110	Escutcheon, Kinescope (Model 509)	7D110
22D232	Glass, safety (clear) (Model 510)	22D232
7C111	Escutcheon, panel (Model 509)	7C111
15B147	Knob, VERTICAL & VOLUME (Models T-64, 510)	15B147
15B147-2	Knob, VERTICAL & VOLUME (Model 509)	15B147-2
15B146	Knob, HORIZONTAL & BRIGHTNESS	15B146
15B148	Knob, CONTRAST	15B148
15B148-2	Knob, CONTRAST (Model 509)	15B148-2
17A041-2	Knob, pushbutton and FINE TUNING	17A041-2
60A347	Switch, toggle DPDT, NORMAL-CIRCLE	60A347

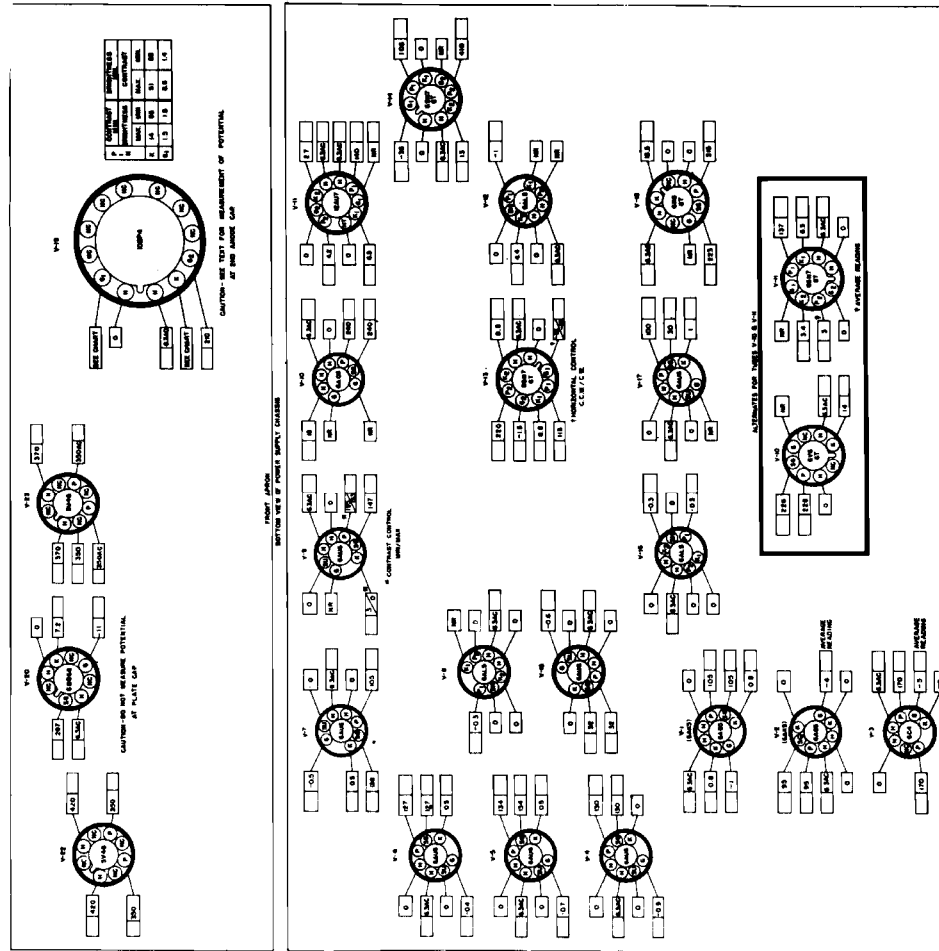

Fig. 17. Tube socket voltage chart.

SERVICE PARTS LIST (Cont.)

Ref. No.	Description	Hallcrafters' Part Number
R-115	2.5 megohms, HEIGHT control	25B788
R-116	2200 ohms 1 watt, carbon	RC30AE222K
R-118	4.7 megohms 1/2 watt, carbon	RC20AE475M
R-119	20 ohms 1 watt, carbon	RC30AE200J
R-120	390 ohms 1 watt, carbon	RC30AE391J
R-121	47 ohms 2 watts, carbon	RC40AE470K
R-122	47,000 ohms 1/2 watt, carbon	RC20AE473K
	TRANSFORMERS AND COILS	
	Transformer, ratio detector	50B406
	Transformer, audio output (Part of speaker assy.)	55C113-1
	Transformer, horizontal output	59C170-2
	Transformer, power	59C170-2
	Transformer, vertical osc.	55B115

MODELS T64, 509, 510

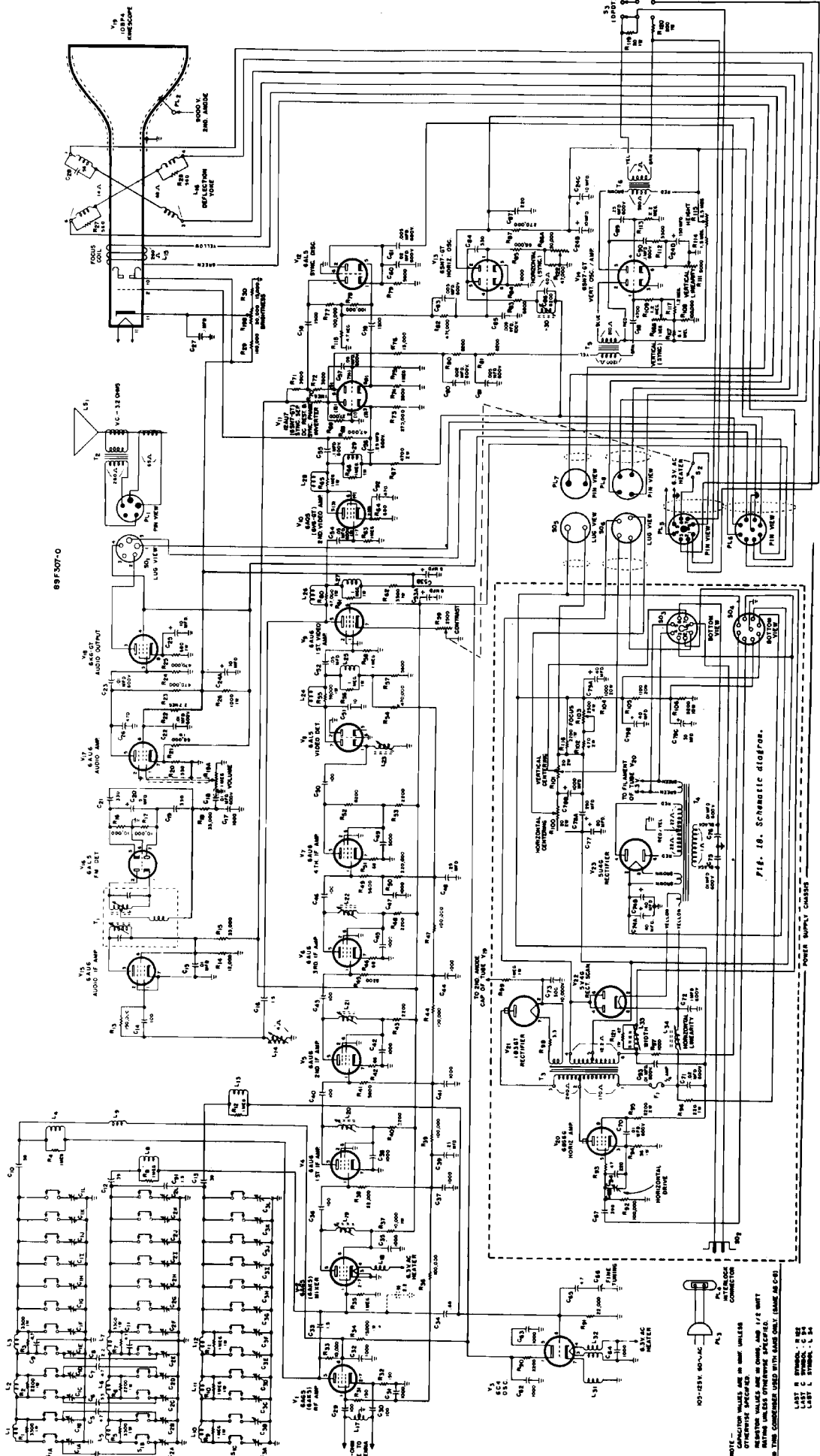

FIG. 18. Schematic diagram.

NOTE: CONDUCTOR VALUES ARE IN OHMS UNLESS OTHERWISE SPECIFIED.
 ALL CAPACITORS ARE OF THE 50V TYPE UNLESS OTHERWISE SPECIFIED.
 ALL TUBES CONSUMER USED WITH THIS SET ONLY (NAME AS C-8).

LIST B RESISTORS: 200
 LIST C RESISTORS: 100