

35/4002

SHOWING T 20. 9 M.W. 2 "CATHOVISOR" TUBE IN POSITION

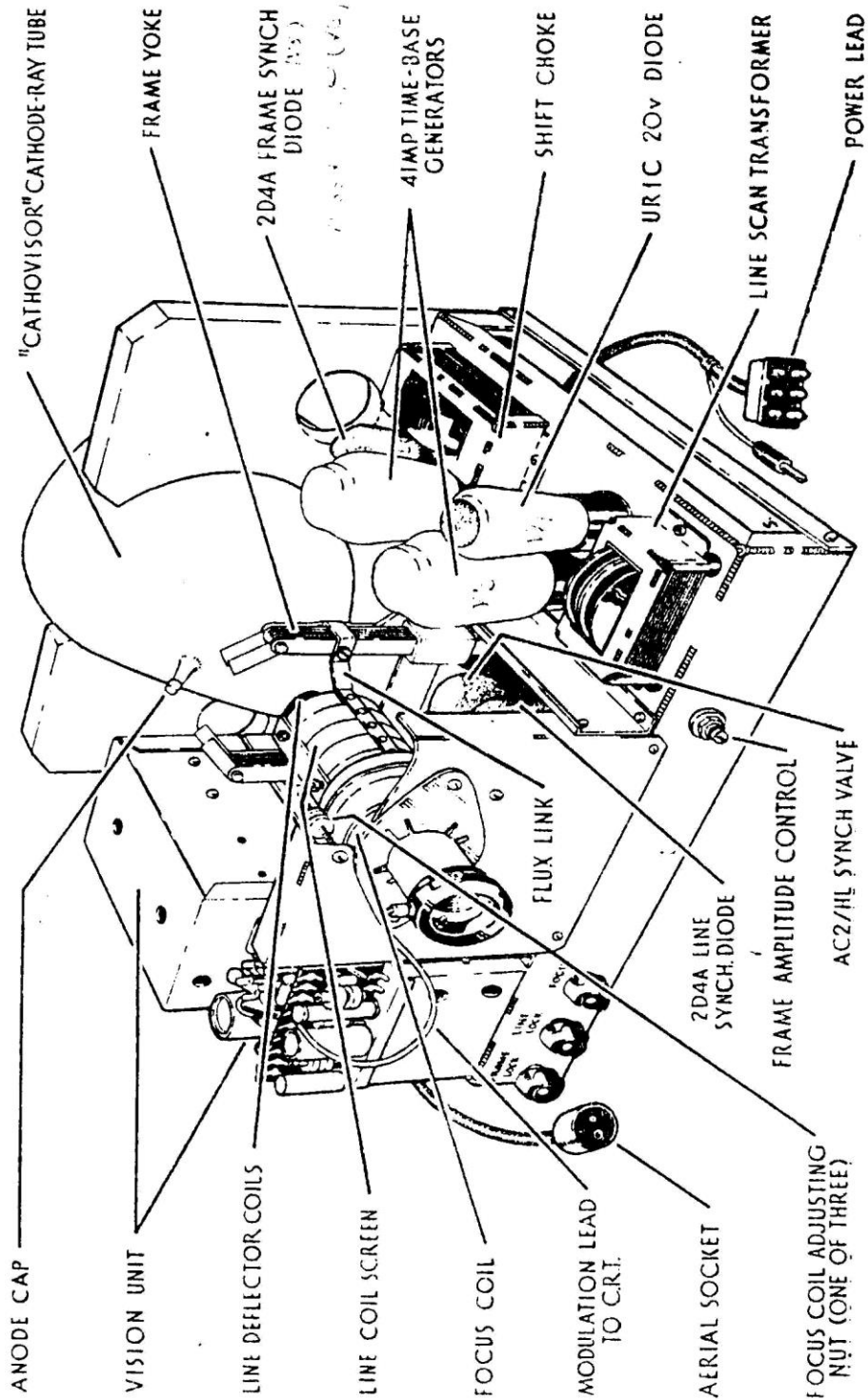

35/6001

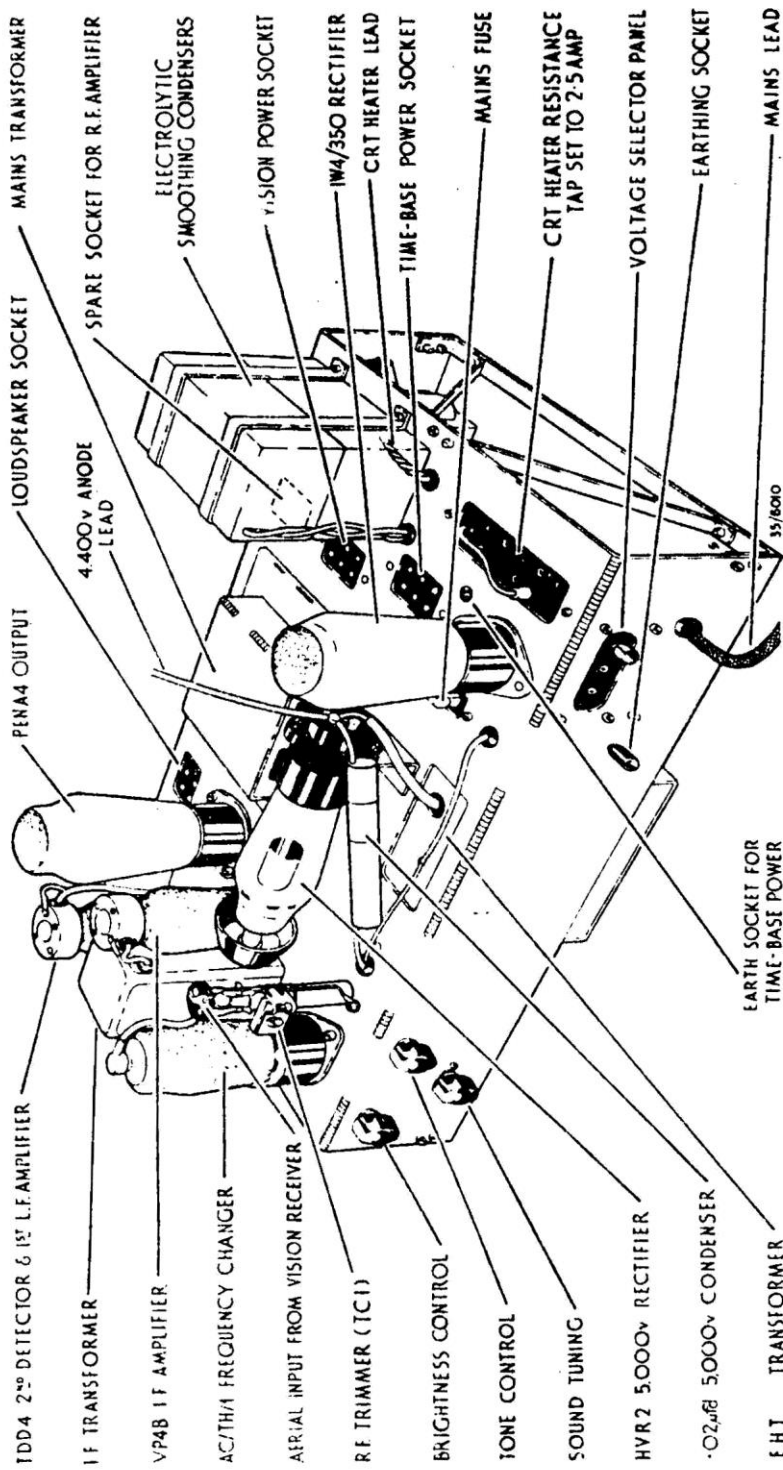

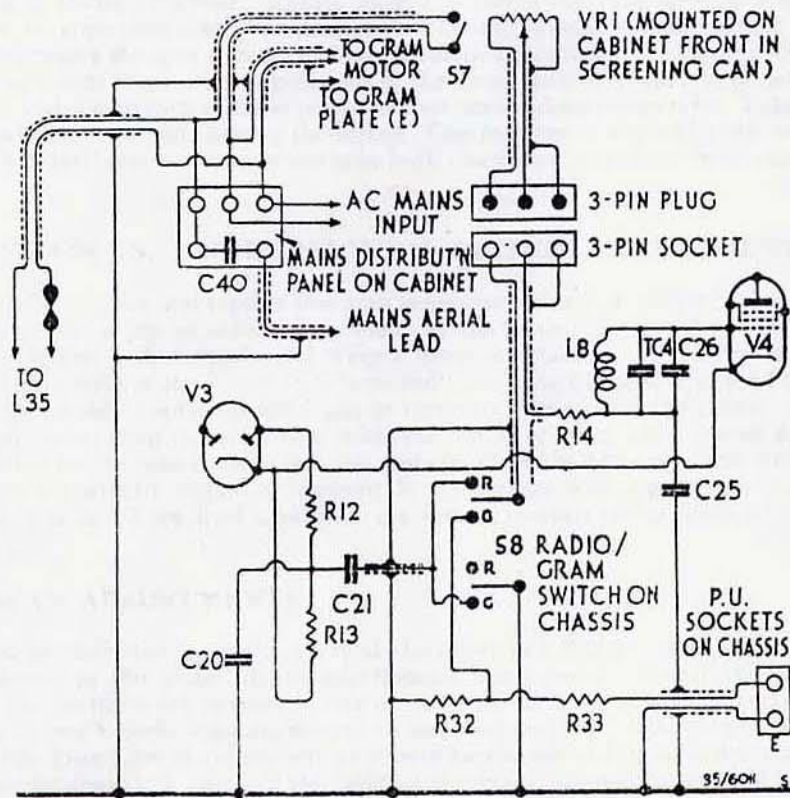
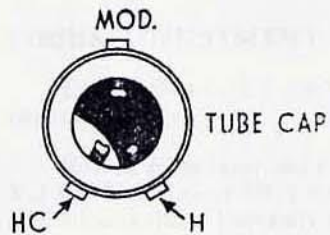
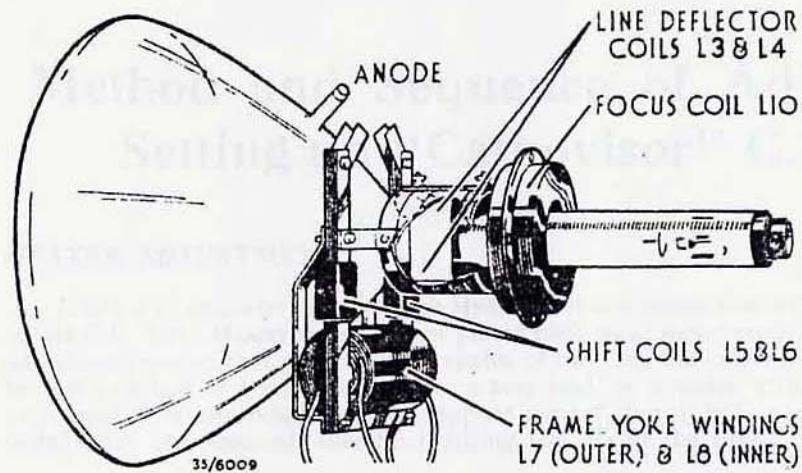

This diagram to be used in conjunction with T.18 sound diagram on Section 12 (3), additional components are:

- R.32. 100K $\frac{1}{2}$ w.
- R.33. 250K $\frac{1}{2}$ w.
- S.8. D.P./C.O. Switch
- C. 37 on Section 12 (3) deleted when used for T.21.

Method and Sequence of Adjustments in Setting up "Cathovisor" C.R. Tube

HEATER ADJUSTMENT

Insert A.C. ammeter in series with Heater lead and connection socket on base of C.R. Tube and adjust C.R. Tube Heater resistance on power pack until meter reads 2.5 amp. When making this adjustment ensure that a short lead capable of carrying the current is used, as .2 amp. can easily be lost in a bad or frayed connection, a long lead, or a meter with a high resistance, and under such conditions the reading would appear correct, but C.R.T. heater would be overrun when meter leads are removed, thereby reducing the life of the tube.

FOCUS ADJUSTMENT (SPOT)

Ensure that C.R.T. neck is in centre of focus coil by adjusting paxolin locating disc on focus support bracket.

Reduce *Brightness and Contrast* to minimum and remove Line and Frame scan generator valves V.3 and V.6. Insert 7K,4 watt resistor between V.3 anode and earth. (This to obtain focus current in the focus coil). Carefully turn Brightness up until spot is visible, adjust focus coil adjusting nuts until spot is in centre of screen. Rotate focus coil round the tube until spot is circular in shape when set to be approximately $\frac{1}{8}$ " in diameter. The spot should remain circular when focus control is turned and causes the spot to reduce in size through a minimum and then up again to $\frac{1}{8}$ " diameter. It will be found that there are two positions of the focus control where it is possible to obtain a spot $\frac{1}{8}$ " diameter, and it is to each of these positions that these adjustments refer. Take great care to keep the Brightness low to avoid burning the screen. Coil rotation is limited by the connecting wire, but approximately 180° movement is possible in both clock and anti-clock directions.

LINE SCAN FOCUS, AND HORIZONTAL PICTURE ADJUSTMENTS

Remove 7K resistor and replace line scan generator valve V.3. Adjust focus control until a thin fine horizontal line is traced across the screen. If the focus control will not give sufficient adjustment, vary the line lock control until correct focus is obtained. If the line is not of even width all over its trace, remove the Line Coil Screen and Flux Link Clamps, readjust Focus and Line Lock controls as previously explained until line is correctly focussed in the centre, and adjust the line deflector coils in relation to each other until the line is *of equal width overall and horizontal*. The correct position for the coils is when they are equally spaced in relation to each other. It is important that the line is correctly adjusted horizontally, or picture will appear twisted. Reassemble the Line Coil Screen and Flux Links, taking care not to disturb the position of the coils.

FRAME SCAN ADJUSTMENTS

The Frame deflection is in the vertical direction and it is not necessary to make individual focus adjustment in this plane, all the adjustments being concerned with the vertical shape of the picture. If the verticals are twisted in one direction, that is, both sides of picture parallel but not vertical, the Frame Yoke fixing nuts should be loosened and the whole yoke twisted in the required direction. The Flux Link clamping screws should be slackened first in order that the line deflector coils will not be disturbed. Should the limit of the yoke traverse be reached before the necessary vertical correction is obtained, secure yoke in its optimum position and make further adjustment by rotation of the line coil screen only (*not line deflector coils which must be left in their correct*

horizontal position). These adjustments can best be made by removing modulation and reducing line amplitude by altering Line Lock control until both sides of the screen are visible inside the mask. Should trapezoidal distortion be present (*i.e.*, the picture wider at the top than at the bottom or vice versa) the two pairs of arms on the top of the frame yoke should be adjusted until the distortion is removed. Finally, adjust Frame Amplitude control until picture height is in correct ratio to picture width.

PICTURE CENTRING

The picture should always be centred in the mask under transmission *picture conditions*. That is during a transmission in which the blackouts are in their correct ratio. It is not advisable to centre a picture on the cross test bar as the blackouts are too wide and differ from the normal transmission. Picture centring is accomplished by rotating the three Focus Coil Adjusting Nuts individually until picture is central in the mask.

FOCUS

The focus control should always be the final time base adjustment, and if it is not possible to obtain focus by rotation of control, first ensure that the correct main's tap is connected, and then check whether the focus control is at its maximum or minimum resistance.

Maximum resistance = Rotated clockwise from the back.

Minimum resistance = Rotated anti-clockwise from the back.

If control is at maximum resistance move the focus coil towards the back of the set. If at minimum resistance move coil towards the screen. (The focus coil needs more current to focus the electron beam when near the anode or gun, and less current when nearer to the screen. Focus control is a Variable resistance which takes more current through the coil when resistance is lowest). Picture must now be re-centred as described, if this adjustment is made.

SYNCHRONISING

When setting lock controls do so with low picture contrast as this is the worst receiving condition and synchs., will hold over the minimum to maximum contrast range.

Frame Lock should be set so that the picture locks when running upward.

Line Lock should be set in a hard lock position, which may be recognised by the whole picture moving from right to left when coming into the correct lock position.

Turn vision contrast control V.R.1 to left, thereby switching off the E.H.T. volts to avoid possibility of high voltage shocks.

Set volume control V.R.1 to maximum.

Set tone control V.R.2 to low (anti-clock from front).

Connect A.C. output meter (with condenser in series) between the anode of the output valve V.5 and chassis. The meter should be capable of giving a reasonable deflection at about 20 volts.

I.F. ALIGNMENT

Set the wavechange switch to television with the scale pointer on "Television."

Set the modulated signal generator to 2.5 megacycles and connect to the control grid (top cap) of the frequency changer valve V.1.

Adjust the television I.F. trimmers T.C.12 and T.C.15 for maximum output. (Coils L.21, L.24.)

Set the wavechange switch to medium waves and pointer to approximately 300 metres.

Set the signal generator to 465 kilocycles and feed into the control grid (top cap) of the I.F. valve V.2. Adjust carefully broadcast I.F. trimmers T.C.13 and T.C.14 for maximum output. (Coils L.22, L.23.)

Transfer generator output to the control grid of the frequency changer and trim T.C.6 and T.C.7. (Coils L.17, L.18.)

After the alignment of the broadcast I.F.'s switch back to Television and with generator at 2.5 megacycles re-check the television I.F. alignment T.C.12 and T.C.15.

R.F. ALIGNMENT (LONG WAVEBAND)

Set the signal generator and the scale pointer to 1,300 metres (230 kilocycles).

Feed the generator into the aerial and earth sockets through a standard dummy aerial.

Adjust oscillator trimmer T.C.10 and aerial trimmer T.C.3. (Coils L.16, L.6.)

Check calibration at 1,800 metres (167 kilocycles).

MEDIUM WAVEBAND

With generator and scale pointer at 200 metres (1,500 kilocycles) adjust oscillator trimmer T.C.9 and aerial trimmer T.C.2. (Coils L.14, L.4.)

Check at 300 and 500 metres (1,000 and 600 kilocycles).

SHORT WAVEBAND

Feed generator into aerial socket through a 400 ohm resistance. With scale pointer set to 20 metres (15 megacycles) adjust oscillator trimmer T.C.8 (Coil L.12) on the peak requiring the smaller trimmer capacity (*i.e.*, oscillator frequency high). Adjust aerial trimmer T.C.1 (Coil L.2). Check at 50 metres (6 megacycles).

TELEVISION

The television R.F. alignment must be carried out feeding the generator into the aerial lead to the vision receiver and *not* with the generator connected directly into the sound receiver.

A generator with an accurate frequency calibration at 41.5 megacycles and an output impedance of 75 ohms is essential.

A non-metallic trimmer screwdriver must be used.

If there be any doubt about the accuracy of the generator it is better to use the tuning signal of an actual transmission, preferably from a weak aerial.

Set the pointer in the middle of the word "Television."

Adjust oscillator trimmer T.C.1 (Coil L.20) on the peak requiring the *larger* trimmer capacity (*i.e.*, oscillator frequency *low*).

Adjust R.F. trimmer T.C.5 (Coil L.10) and aerial trimmer T.C.4 (Coil L.8) for maximum output.

Turn vision contrast control V.R.3 to left thereby switching off the E.H.T. volts and avoiding possibility of shocks.

Set volume control V.R.1 to maximum.

Set tone control V.R.2 to low.

Connect A.C. output meter, with condenser in series, between V.4 anode and chassis. A meter giving a reasonable deflection at about 20 volts should be used.

I.F. ALIGNMENT

Set the modulated signal generator to 2.5 megacycles and feed into the control grid of V.1.

Adjust the I.F. trimmer T.C.3 (Coil L.3) for maximum output.

Adjust the I.F. trimmer T.C.6 (Coil L.6) for maximum output.

R.F. ALIGNMENT

The R.F. alignment must be carried out feeding the signal generator into the aerial lead to the vision receiver, and *not* with the generator connected into the sound receiver.

A signal generator with an accurate and stable frequency calibration at 41.5 megacycles and an output impedance of 75 ohms must be used. Should there be any doubt about the generator accuracy it is advised that the B.B.C. Tuning Signal be used for R.F. alignment, preferably from an aerial giving a weak signal.

A non-metallic trimmer screwdriver must be used.

Set the tuning control T.C.5 approximately at half capacity and adjust T.C.2 (Coil L.4, L.5) for maximum output, on the peak requiring the larger trimmer capacity (oscillator frequency low). It may be found that there is only one peak position, if so this is the correct one.

Adjust R.F. aerial coil trimmer T.C.1 for maximum output.

AERIAL FEED

The aerial feeder cable which must be terminated in the non-reversible two-pin plug (Section 13 (1)) is plugged into aerial socket (Section 10 (2)) and the sound aerial plug from the vision unit is taken to the sound aerial socket on the power pack and sound unit (Section 10 (1) and (3)).

VISION UNIT

The unit comprises two tuned radio frequency band-pass coupled stages with three megacycle band-pass, diode detector and video amplifier, incorporating three Mullard TSE4 secondary emission valves and Mazda D1 special low capacity diode rectifier.

VISION SIGNAL

The radio frequency signal from the television aerial is fed via sound reject circuit L.1, V.C.1 to the grid circuit L.2, V.C.2, of the first R.F. valve V.1, amplified and applied to the second R.F. amplifier valve V.2 via band-pass coils L.3 and L.10 (L.8 coupling coil). The amplified output of V.2 is applied via similar band-pass coils L.11, L.13 (L.12 coupling coil), into low capacity diode rectifier and the video frequencies developed across the diode load resistance R.19 are applied to the grid of V.4 via L.14. Amplification at video frequency is given by V.4. Positive picture modulation voltages are developed at the anode of V.4 which is capacity coupled to the modulator electrode of the "Cathovisor" C.R. tube, by the flying lead from the end tag on the sub-assembly panel. The auxiliary cathode of V.4 gives output volts in the opposite sense for the time base synchronising selector circuit.

Picture contrast and R.F. sensitivity of the vision unit is controlled by V.R.3 (Sections 12 (3) and 15 (2)). Switches S.5 and S.6, which are ganged to V.R.3, switch "Cathovisor" Tube heater supply and the mains to E.H.T. transformer. S.5, S.6 operate to OFF when V.R.3 is turned anti-clockwise (low contrast), allowing television sound only to be used with economy.

TIME BASE UNIT

- AC2/HL. Triode synch. separator valve.
- 41.MP or AC₁P. Triode frame scan generator valve.
- 41.MP. Triode line scan generator valve.
- U.R.1.C. Diode line scan generator valve.
- 2D4A. Diode frame synch. coupling valve.
- 2D4A. Diode line synch. coupling valve.

SYNCHRONISING PULSE SELECTION

The voltages at the auxiliary cathode of V.4 valve (vision unit) are capacity coupled to the grid of the pulse selector valve (V.1 time base), which removes all modulation other than 50 and 10,125 cycle frame and line speed synchronising pulses. The selected pulses synchronise the scan generator valves V.3 and V.6, as later described.

LINE SYNCHRONISING

The 10,125 cycle pulses are fed from the anode of V.1 (time base) via condenser C.3 to cathode of diode valve V.2 which valve injects the line speed synch. pulses on to the grid of the line scan generator valve V.3.

LINE SCAN GENERATOR CIRCUIT

Electromagnetic principle is employed for line deflection.

V.3 valve with scan transformer coils L.1 and L.2 form an oscillatory circuit which develops a linear saw-toothed current waveform in the line deflector coils L.3 and L.4, which are connected

across L.2 and arranged round the neck of the "Cathovisor" C.R. tube. The current flowing through these coils forms an electromagnetic field which deflects the electron beam in the "Cathovisor" tube horizontally at the line frequency of 10,125 c.p.s. (405 lines per frame). The speed of the generator is controlled by V.R.1 (line lock) and limited by the value of R.7. The diode valve V.4 is connected to V.3 generator valve, anode to cathode and cathode to anode, this circuit arrangement increasing the efficiency of the generator. The diode cathode bring at V.3 anode potential a U.R.I.C. valve with 20v. heater is used as this valve has high voltage insulation between heater and cathode.

FRAME SYNCHRONISING

Synchronising pulses are fed from V.1 anode via resistor R.4 and line pulses filtered from the circuit by R.5 and C.4, which two components form a resistance capacity filter. The filtered 50 cycle pulses are coupled via diode valve V.5 which injects frame pulses on to frame scan generator valve, grid V.6.

FRAME SCAN GENERATOR CIRCUIT

Electromagnetic principle is also employed for frame deflection.

V.6 valve and oscillator transformer coils L.7 and L.8 form an oscillatory circuit, coils L.7, L.8 being integral with the deflector yoke. A linear 50 cycle sawtoothed current waveform is developed in L.8 winding of the frame yoke which deflects the beam vertically at frame speed. The speed is controlled by V.R.2, and the amplitude by preset control V.R.4. A magnetic shift is introduced to counteract the magnetic deflection caused by the direct current flowing in the anode winding L.7, by passing this same current through shift coils L.5 and L.6 which are also assembled on the frame yoke but arranged electrically in opposition to L.7. The shift choke L.9 prevents resistance loading of the oscillator circuit.

"CATHOVISOR" CATHODE RAY TUBE

The construction of the Baird "Cathovisor" Cathode Ray Tube has been greatly simplified. The internal assembly consists of the following electrodes :—

- | | | |
|---------------------------------|---|-----------------------------------------|
| (1) Heater and cathode combined | } | For cap connections see Section 10 (4). |
| (2) Modulator | | |
| (3) Anode | | |

The heater is A.C. fed and the current regulated to 2.5 amperes. The anode is at 4,800v. potential on Type 12 M.W.2, C.R. Tubes, 4,400v. potential Type 9 M.W.2. The high voltage connection to the anode is made on the side of the glass envelope. Picture modulation from V.4 anode (vision unit) is applied to the modulator electrode via C.25 and controls the electron beam, thereby varying the picture contrast according to the video frequency voltages developed by the vision unit. Brightness is controlled by a variable positive cathode bias voltage obtained from a variable potentiometer across the main H.T. supply V.R.4, Sections 12 (3), 15 (2). The modulator electrode is connected to earth via R.18 (Vision unit).

FOCUS

Focus of the electron beam is effected electro-magnetically. Anode current taken by valves V.3, V.6 through focus coil L.10 produces an approximately correct magnetic focussing field, L.10 being located round the neck of the "Cathovisor" tube. Accurate adjustment of focus is made by V.R.3 Focus Control, a limited variable resistance between L.10 and earth.

T.18 and T.21 POWER PACK AND SOUND UNIT

The four wave-band superheterodyne sound receiver is integral with the power pack chassis.

T.18 BROADCAST BAND SPECIFICATION

- V.1. TH4A or TH4B triode hexode frequency changer.
- V.2. VP4B. H.F. pentode intermediate frequency amplifier.
- V.3. 2D4A. Double diode second detector and A.V.C. rectifier.
- V.4. SP4B. Pentode audio amplifier.
- V.5. PEN. B4. Pentode output valve.

Radio frequency input from the aerial is coupled to triode hexode frequency changer valve V.1 with aerial coils L.1 to L.6 and R.F. signals amplified and converted to 465 kilocycles intermediate frequency. V.2 valve amplifies the signal at I.F. and double diode valve V.3 rectifies the I.F. signal giving rectified volts for A.V.C. and for amplification at audio frequency. Two stages of audio frequency amplification are employed, pentode amplifier V.4 and pentode output valve V.5. A.V.C. is fed to both V.1 and V.2 on medium and long wavebands; to V.2 only on short and television wavebands. Volume is controlled by V.R.1; audio frequency voltages developed across diode load resistors R.12, R.13 are fed via V.R.1 to grid of V.4. Tone control V.R.2, C.23 is connected between V.5 grid coupling condenser C.22 and earth.

T.18 TELEVISION SOUND WAVEBAND SPECIFICATION

- V.4. Reflex R.F. pentode amplifier.
- V.1. Triode hexode frequency changer.
- V.2. Pentode intermediate frequency amplifier.
- V.3. Double diode detector and A.V.C. rectifier.
- V.4. Pentode audio amplifier.
- V.5. Pentode output valve.

The same valves are employed for the television sound receiver as in the broadcast receiver, but the circuit arrangement and intermediate frequency used are different. Intermediate frequency on television band is 2.5 megacycles instead of 465 kilocycles, the audio amplifier pentode valve V.4 is used also as a reflex radio frequency amplifier. This arrangement alters the circuit specification adding an extra R.F. stage.

The television R.F. sound signal is fed from the aerial via R.1 (Vision unit), coupling coil L.7 and aerial coil L.8 to the grid of pentode valve V.4, amplified at R.F. and applied to the grid of the frequency changer valve V.1 which amplifies and converts the R.F. signal to intermediate frequency of 2.5 megacycles. The signal is amplified at 2.5 megacycles via I.F. coils L.21, L.24 and valve V.2.

Detector A.V.C. and audio amplifier circuit is the same as used on the broadcast bands. A special switching arrangement permits the use of television sound only. (See Vision Unit summary.)

LOUDSPEAKER

A special Rola loudspeaker with 300-ohm field winding and suitable output transformer is used. Section 13 (1).

T.21 RADIO-GRAMOPHONE

Section 10 (4) shows special circuit modifications when T.18 chassis is used for T.21 Radio-gramophone.

Signal voltages from the pick-up are applied to V4 Grid via R32 R33 and V.R.1. Potentiometer circuit R32 R33 reduces the signal voltage to avoid overloading of V.4. V.R.1 and S7 control is removed from the chassis to the front of the cabinet, and Radio Gramophone Switch S8 fitted in its place.

A special loudspeaker is used in the T.21 receiver and C.37 smoothing condenser is removed from the field winding.

POWER PACK

The power pack contains two separate power supplies. The main power for the receiver is supplied from one transformer and 1 W.4 350 rectifier valve V.7 and supplies 330 volts D.C. at 120 milliamps, 4 volts at 20 amperes for heater supplies and 20-volt heater supply for U.R.T.C. valve in the time base.

The 300-ohm loudspeaker field is used for smoothing; additional smoothing required for the vision unit and synch. selector valve is obtained from L.37. The 230-volt tap on the primary of the power transformer is used as an auto transformer to maintain a fixed voltage input to the E.H.T. transformer which gives 3,200 volts A.C. and 4-volt heater feed to an HVR2 half-wave rectifier V.6 which develops a D.C. potential of approximately 4,500 volts. This potential is connected in series with the main 330-volt D.C. power supply making a total effective voltage to the 12 M.W.2 "Cathovisor" tube anode of 4,800 volts.

The "On"/"Off" mains switch is ganged to V.R.1 sound volume control.

T.20 POWER PACK AND SOUND UNIT SOUND SPECIFICATION

Four-valve 7.23 metre superheterodyne receiver.

V.1. AC/TH1. Triode hexode frequency changer.

V.2. VP4B. Pentode I.F. amplifier.

V.3. TDD4. Double diode second detector A.V.C. rectifier and triode amplifier.

V.4. PEN/A4. Pentode output valve.

The television radio frequency sound signal is fed through R.1 (vision) and coupled to R.F. tuning coil L.2 with coupling coil L.1. The aerial feed from the vision unit is terminated in a non-reversible two-pin plug and must be connected to the appropriate socket on the L.1, L.2 coil (see Section 10 (3)), which is connected to the grid of frequency changer valve V.1. V.1 amplifies the R.F. signal and converts to I.F. of 2.5 megacycles. The triode portion of V.1 and coils L.4, L.5 form the oscillator circuit, which is tuned by T.C.2 and external pre-set T.C.5. I.F. amplification is given by V.1, L.3 and V.2, L.6. The double diode portion of V.3 rectifies the I.F. signal for audio amplification and A.V.C. I.F. signals from V.2 anode are rectified by V.3 then applied to V.2 grid via R.6, R.5, giving A.V.C. in the I.F. amplifier circuit.

Modulation voltages developed across diode load resistances R.9 and R.10 are coupled via C.14 and V.R.1 (volume control) to the grid of V.3 first stage audio amplifier. From V.3 anode C.17 couples the signal to the grid of V.4 pentode output valve. Tone control C.16 V.R.2 is connected between V.3 anode and earth.

A special switching arrangement permits the use of television sound only (see Vision Unit Summary).

LOUDSPEAKER

A special Rola loudspeaker with 300-ohm field winding and output transformer to match V.4 Pentode.

T.20 POWER PACK

The power pack consists of two separate power supplies. The main power for the receiver is supplied from one transformer and I.W.4 350 rectifier valve V.5, and supplies 330 volts D.C. at 120 milliamperes, 4 volts at 20 amperes for heater supplies, and 20-volt heater supply for U.R.I.C. valve in the time base.

The 300-ohm loudspeaker field is used for smoothing. Additional smoothing required for the vision unit and synch. selector valve is obtained from L.9. The 230-volt tap on the primary of the power transformer is used as an auto transformer to maintain a fixed voltage input to the E.H.T. transformer which gives 3,200 volts A.C. and 4-volt heater feed to H.V.R.2 rectifier V.6 developing a D.C. potential of approximately 4,400 volts.

The "On"/"Off" main switch is ganged to V.R.1 (sound volume control).

RESISTORS

K = X 1000
W = Wattage.
M = Megohm.

✓R.1.	1M	—	1/2w.
✓R.2.	150 ohms	—	1/2w.
✓R.3.	50K	—	1/2w.
✓R.4.	75K	—	1/2w.
✓R.5.	20K	—	2w.
✓R.6.	50 ohms	—	1/2w.
✓R.7.	50 ohms	—	1/2w.
✓R.8.	5M	—	1/2w.
✓R.9.	250 ohms	—	1/2w.
✓R.10.	100K	—	1/2w.
✓R.11.	10K	—	1/2w.
✓R.12.	250K	—	1/2w.
✓R.13.	1M	—	1/2w.
✓R.14.	50K	—	1/2w.
✓R.15.	300 ohms	—	1/2w.
✓R.16.	500K	—	1/2w.
✓R.17.	100K	—	1/2w.
R.18.	5K	—	1/2w.
R.19.	10K	—	1/2w.
R.20.	10K	—	1/2w.
✓R.21.	5K	—	1/2w.
✓R.22.	100K	—	1/2w.
✓R.23.	10K	—	1/2w.
✓R.24.	2M	—	1/2w.
✓R.25.	250K	—	1/2w.
✓R.26.	250 ohms	—	1/2w.
✓R.27.	80K	—	1w.
✓R.28.	400 ohms	—	3w.
✓R.29.	50 ohms	—	1/2w.
R.30.	.07. Eureka Wire.		
R.31.	300 ohms	—	1w.

CONDENSERS

T = Tubular.
E = Electrolytic.

C.1.	.0008 mfd.	
C.2.	0.5 mfd.	T
C.3.	.05 mfd.	T
C.4.	.05 mfd.	T
C.5.	100 P.F.	
C.6.	100 P.F.	
C.7.	556 P.F.	
C.8.	316 P.F.	
C.9.	100 P.F.	
C.10.	180 P.F.	
C.11.	180 P.F.	
C.12.	180 P.F.	
C.13.	180 P.F.	
C.14.	0.1 mfd.	T
C.15.	.05 mfd.	T
C.16.	.05 mfd.	T
C.17.	.05 mfd.	T
C.18.	.0001 mfd.	T
C.19.	.0001 mfd.	T
C.20.	.0001 mfd.	T
C.21.	.02 mfd.	T
C.22.	.02 mfd.	T
C.23.	.02 mfd.	T
C.24.	.001 mfd.	T
C.25.	50 P.F.	
C.26.	25 P.F.	
C.27.	0.25 mfd.	T
C.28.	.02 mfd.	T
C.29.	50 mfd.	E
C.30.	50 mfd.	E
C.31.	2 mfd.	E
C.32.	16 mfd.	E
C.33.	16 mfd.	E
C.34.	16 mfd.	E
C.35.	0.25 mfd.	T
C.36.	0.1 mfd.	T
C.37.	0.35 mfd.	T
C.38.	8 mfd.	E
C.39.	.02 mfd.	T
C.40.	.001 mfd.	T
C.41.	.05 mfd.	T

VARIABLE RESISTORS

V.R.1.	500.K Pot. Audio Volume Control. Ganged to S.7
V.R.2.	100.K Pot. Audio Tone Control
V.R.3.	5K. Vision Contrast Control
V.R.4.	10.K Pot. Brightness Control
V.R.5.	0.9 ohm. Tapped C.R. Tube Heater resistance

SWITCHES

S.1.	} 4-way Yaxley ganged wave change switches.
S.2.	
S.3.	
S.4.	
S.5.	C.R.T. Heater switch ganged to V.R.3. Vision
S.6.	E.H.T. Mains transformer, ganged to V.R.3. Vision
S.7.	Main On Off Switch ganged to V.R.1.

LOUDSPEAKER

Rola. Type F.6
D.C. resistance of field = 300 ohms
D.C. resistance of O/P Transf. Primary L25 = 250 ohms
D.C. resistance of O/P Trans. Sec. L26 = 0.3
Speech Coil Impedance = 2 ohms
L. S extension is in parallel with L.26. No transformer is required.

VARIABLE CONDENSERS

V.C.1.	} Ganged Tuning Condenser
V.C.2.	
	.0005 mfd.
	.0005 mfd.

POWER SOCKET

Power Sockets 6-way Carr.
Aerial Sockets 2 way Carr.

COILS

- L.1. S.W. Aerial Coupling Coil
- L.2. S.W. " Tuning "
- L.3. M.W. " Coupling "
- L.4. M.W. " Tuning "
- L.5. L.W. " Coupling "
- L.6. L.W. " Tuning "
- L.7. Tel. " Coupling "
- L.8. Tel. " Tuning Coil
- L.9. Tel. R.F. " "
- L.10. Tel. R.F. Coupling Coil
- L.11. S.W. Oscillator Secondary Coil
- L.12. S.W. " Primary "
- L.13. M.W. Osc. Secondary "
- L.14. M.W. " Primary "
- L.15. L.W. " Secondary "
- L.16. L.W. " Primary "
- L.17. 465. K.C. 1st I.F.T. Primary Coil
- L.18. " " Secondary Coil
- L.19. Tel. Oscillator Secondary Coil
- L.20. " " Primary "
- L.21. Tel. 2.5 mcs. 1st I.F. Coil
- L.22. 465 K.C. 2nd I.F.T. Primary Coil
- L.23. " " Secondary Coil
- L.24. Tel. 2.5 mcs. 2nd I.F. Coil
- L.25. L.S. O/P Transf. Primary
- L.26. " " Secondary
- L.27. E.H.T. Mains Transf. Primary
- L.28. " " 4V Rect. winding
- L.29. " " 3,200V E.H.T. Secondary Winding
- L.30. 4v. 20 amp. Heater Winding for Vis. T.B. and Sound
- L.31. 20v. winding for U.R.1.C. (V.4) Time Base
- L.32. C.R. Tube Heater winding
- L.33. 4 volt winding for 1W4/350 Rectifier V.7.
- L.34. H.T. Secondary 330-0-330
- L.35. Mains Transformer Primary
- L.36.
- L.37. Smoothing choke

VALVES

- V1 TH4A or B Mullard
- V2 VP4B "
- V3 2D4A "
- V4 SP4B "
- V5 PEN.B4 "
- V6 HVR2 "
- V7 1W4/350 "

LAMP

Flame Lamp. 240v. 15 w. Orange

PILOT LAMP

6.2V. 0.3 Amp.

MAINS FUSE

3 Amp. Bulgin

(Continued overleaf)

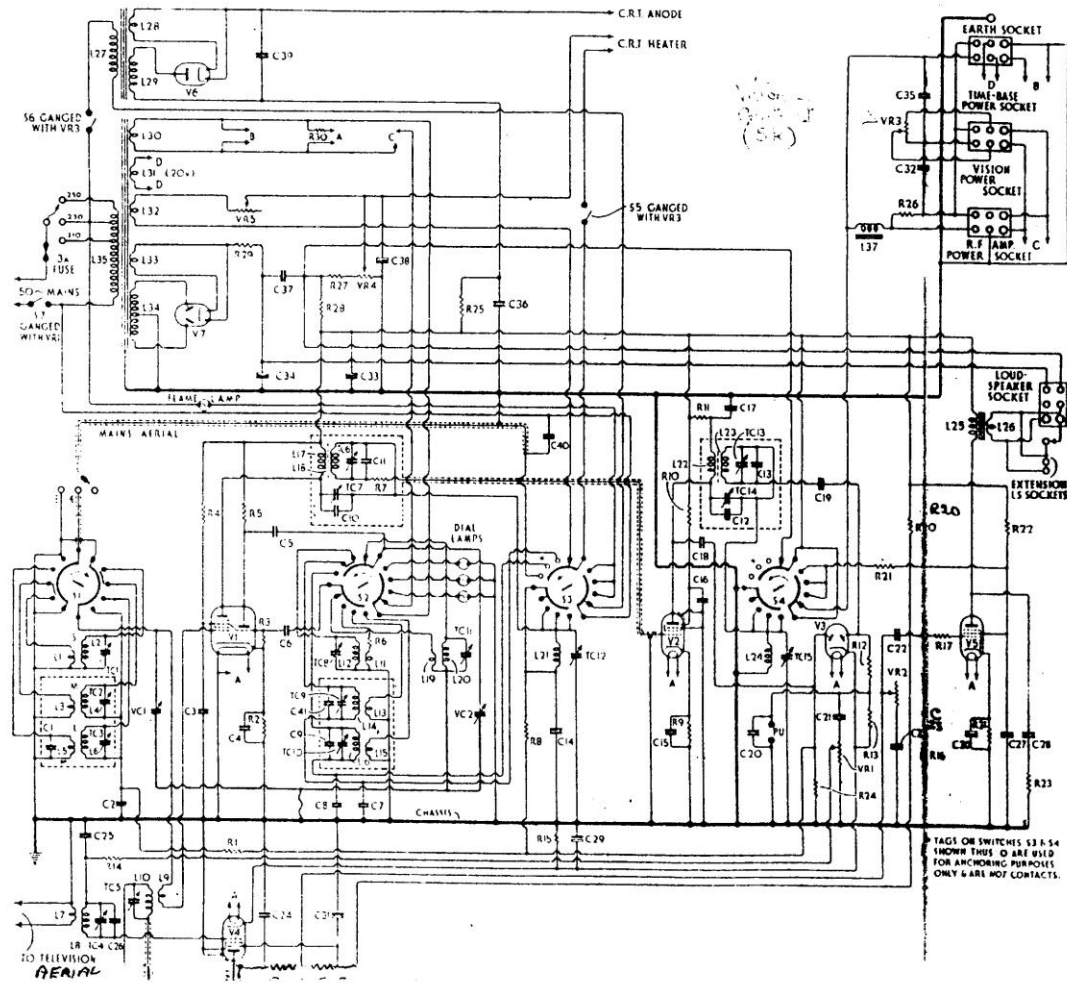

G
H F E
6 5 1
3 4 2

TAGS OR SWITCHES 13 & 54 SHOWN THIS WAY ARE USED FOR ANCHORING PURPOSES ONLY & ARE NOT CONTACTS.

T 18 AND T 20 AERIAL FEEDER CABLE PLUG CONNECTIONS

BRAIDING TO CASE
& SMALLER PIN

CENTRE CONDUCTOR
TO LARGER PIN

SOLDER

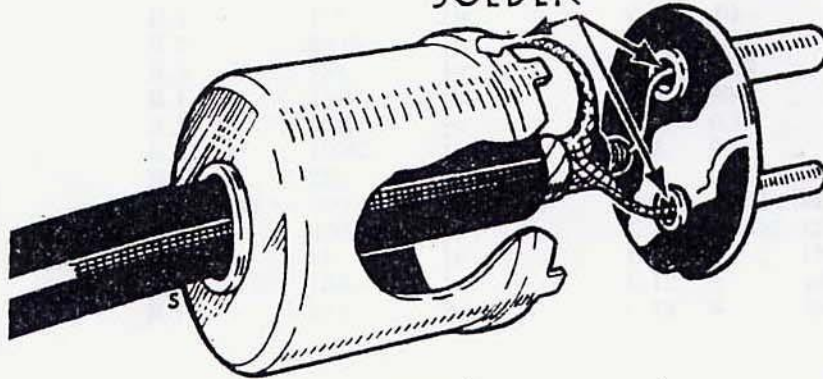

35,6003

T.18 AND T20 LOUDSPEAKER CIRCUIT DIAGRAM

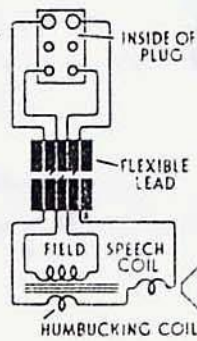

35,6004

RESISTORS

K = X by 1000
W = Wattage
M = Megohm

R.1.	1M.	1w.
R.2.	200K.	1w.
R.3.	15K.	1w.
R.4.	15K.	1w.
R.5.	50K.	1w.
R.6.	100K.	1w.
R.7.	2K.	2w.
R.8.	100 to 500 ohms	1w.
R.9.	0.5M.	1w.
R.10.	1K.	1w.
R.11.	19K.	1w.
R.12.	20K.	2w.

CONDENSERS

T = Tubular
E = Electrolytic

C.1.	0.1 mfd.	T.
C.2.	.01	" T.
C.3.	.001	" T.
C.4.	0.25	" T.
C.5.	50	" E.
C.6.	0.5	" T.
C.7.	0.5	" T.
C.8.	deleted	
C.9.	.0025 mfd.	2000 v.w.
C.10.	8 mfd.	120v.w. E.
C.11.	8	" 120v.w. E.
C.12.	8	" 450v.w. E.
C.13.	8	" 450v.w. E.

VARIABLE RESISTORS

V.R.1. = 2K.
V.R.2. = 2K.
V.R.3. = 50K.
V.R.4. = 20K.

VALVES

V.1. A.C.2/H.L. Mazda
V.2. 2.D.4.A. Mullard
V.3. 41.M.P. Cossor
V.4. U.R.1.C. Mullard
V.5. 2.D.4.A. Mullard
V.6. 41.M.P. Cossor or AC/P Mazda

H.
4 v.
4 v.
4 v.
20 v.
4 v.
4 v.

COILS

L.1. Line Scan oscillator transformer primary.
L.2. Line Scan oscillator transformer secondary.
L.3. Line Deflector coil on C.R.T.
L.4. " " " "
L.5. Shift coil on Frame deflector Yoke.
L.6. " " " "
L.7. Frame deflector oscillator transformer primary.
L.8. Frame deflector oscillator transformer secondary.
L.9. Shift Choke.
L.10. Focus Coil.

CATHODE RAY TUBE

T.18. "Cathovisor" Type 12.M.W.2
T.20. " " " 9.M.W.2

POWER LEAD

Power Lead terminated with 6-way Carr Plug and separate Earthing Plug

RESISTORS

K = X by 1000
W = Wattage

R.1.	75 ohms	—	1/4w.
R.2.	7.5K	—	1/4w.
R.3.	5K	—	1/4w.
R.4.	5K	—	1/4w.
R.5.	5K	—	1/4w.
R.6.	1250 ohms	—	1/4w.
R.7.	150K	—	1/4w.
R.8.	20K	—	1w.
R.9.	35K	—	1w.
R.10.	70K	—	1/4w.
R.11.	5K	—	1/4w.
R.12.	5K	—	1/4w.
R.13.	7.5K	—	1/4w.
R.14.	5K	—	1/4w.
R.15.	1250 ohms	—	1/4w.
R.16.	150K	—	1/4w.
R.17.	20K	—	1w.
R.18.	500K	—	1/4w.
R.19.	10K	—	1/4w.
R.20.	5K	—	1/4w.
R.21.	200 ohms	—	1/4w.
R.22.	5K	—	1/4w.
R.23.	70K	—	1/4w.
R.24.	20K w.w., tapped at 15K + 35 K 1/4w. paralleled		

CONDENSERS

C.1.	30 P.F.
C.2.	100 P.F.
C.3.	.002 mfd.
C.4.	.002 mfd.
C.5.	.002 mfd.
C.6.	.002 mfd.
C.7.	.002 mfd.
C.8.	.002 + .002 mfd.
C.9.	.002 mfd.
C.10.	0.1 mfd.
C.11.	.002 mfd.
C.12.	4 mfd. E
C.13.	.002 mfd.
C.14.	.002 mfd.
C.15.	.002 mfd.
C.16.	.002 mfd.
C.17.	.002 mfd.
C.18.	.002 mfd.
C.19.	.002 mfd.
C.20.	.002 mfd.
C.21.	.002 mfd.
C.22.	.002 mfd.
C.23.	.002 mfd.
C.24.	15 P.F.
C.25.	.02 mfd.
C.26.	.02 mfd.
C.27.	.002 mfd.
C.28.	.002 mfd.
C.29.	200 mfd. E.
C.30.	4 mfd. E.

COILS

L.1.	Sound R.F. Rejector Coil (Capacity tuned)
L.2.	Vision R.F. Grid Coil (Capacity tuned)
L.3.	Vision R.F. Band Pass, Anode Coil (Inductance tuned)
L.4.	R.F. Choke. H.T. Supply 1st valve
L.5.	R.F. Choke. V.1. Screen
L.6.	R.F. Choke. Heater supply V.1.
L.7.	R.F. Choke. Heater supply V.1.
L.8.	R.F. Band Pass, V.2. coup- ling coil
L.9.	R.F. Choke. V.2. Screen
L.10.	R.F. Band Pass, V.2. Grid coil (Inductance tuned)
L.11.	R.F. Band Pass Anode Coil V.2. (Inductance tuned)
L.12.	R.F. Band Pass V.3. Coup- ling Coil
L.13.	R.F. Band Pass V.3. Diode Coil (Inductance tuned)
L.14.	R.F. Choke V.4. Grid
L.15.	R.F. Choke Heater supply V2. V.3
L.16.	R.F. Choke Heater supply V2. V.3
L.17.	R.F. Choke V4. Anode
L.18.	R.F. Choke V4. Auxiliary Cathode

VALVES

V1.	TSE4 Mullard	H
V2.	TSE4 Mullard	H
V3.	D1 Mazda	H
V4.	TSE4 Mullard	H

17-516
 sign Contract

VISION DIAGRAM

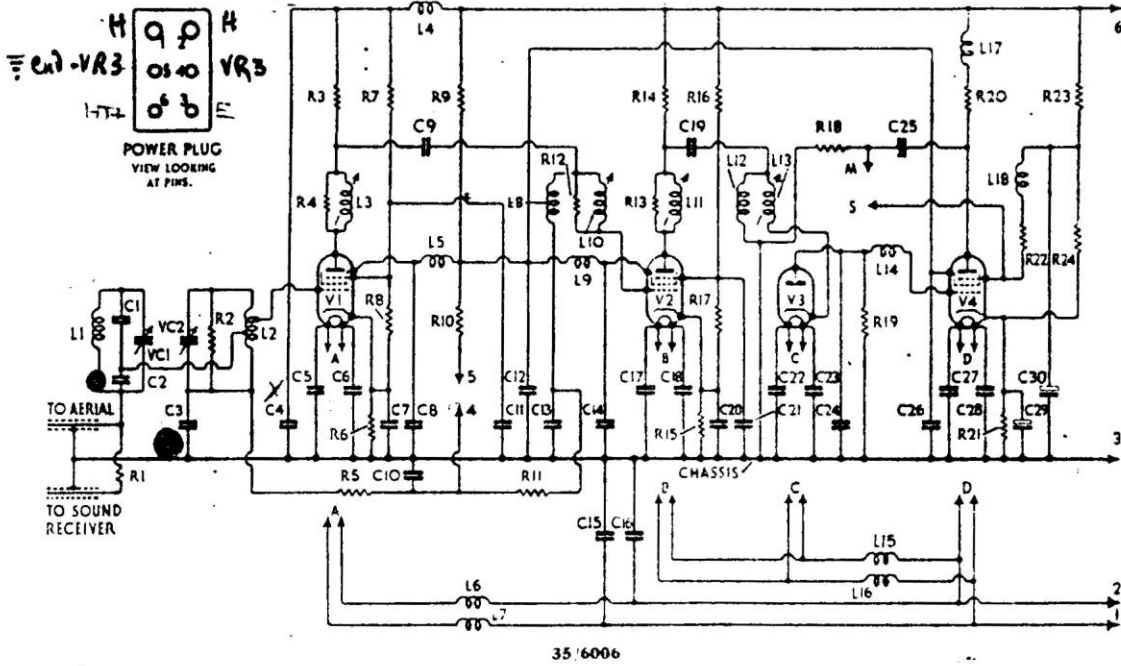

TIME BASE DIAGRAM

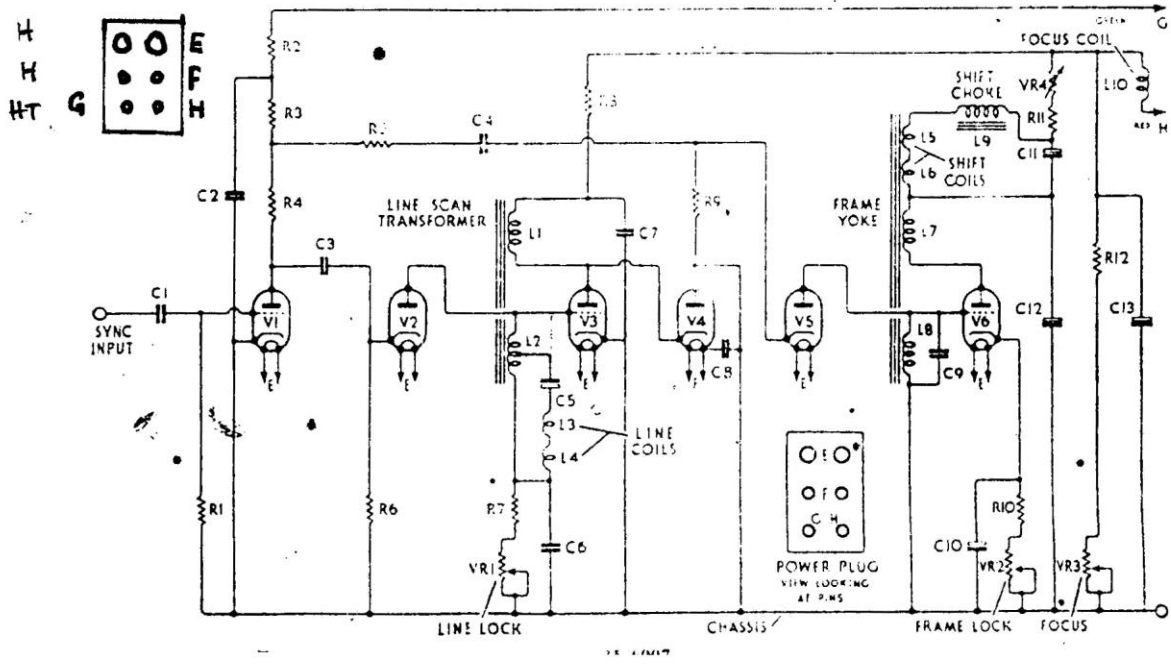

RESISTORS

M = Megohm.
K = X by 1000.
W = Wattage.

- R.1. 50 K. 1.w.
- R.2. 150 ohms $\frac{1}{2}$ w.
- R.3. 50.K. $\frac{1}{2}$ w.
- R.4. 20.K. 2w.
- R.5. 1 M. $\frac{1}{2}$ w.
- R.6. 5 M. $\frac{1}{2}$ w.
- R.7. 100K. $\frac{1}{2}$ w.
- R.8. 100 ohms $\frac{1}{2}$ w.
- R.9. 100K. $\frac{1}{2}$ w.
- R.10. 1 M. $\frac{1}{2}$ w.
- R.11. 500 ohms $\frac{1}{2}$ w.
- R.12. 50K. $\frac{1}{2}$ w.
- R.13. 20K. $\frac{1}{2}$ w.
- R.14. 500K. $\frac{1}{2}$ w.
- R.15. 100K. $\frac{1}{2}$ w.
- R.16. 300 ohms $\frac{1}{2}$ w.
- R.17. 10K. $\frac{1}{2}$ w.
- R.18. 80K. 1w.
- R.19. 250 ohms $\frac{1}{2}$ w.
- R.20. 50 ohms 4w.
- R.21. .07 ohms 20 s.w.g. Eureka.
- R.22. 50K. $\frac{1}{2}$ w.
- R.23. 2 M. $\frac{1}{2}$ w.

VARIABLE RESISTORS

- V.R.1. 500 K. Audio Volume Control
- V.R.2. 100 K. „ Tone Control
- V.R.3. 5 K. Vision Contrast Control
- V.R.4. 10 K. C.R. Tube Brightness control

CONDENSERS

T = Tubular.
E = Electrolytic.

- C.1. 25 P.F.
- C.2. .01 mfd. T.
- C.3. .001 mfd. T.
- C.4. 50 P.F.
- C.5. 50 P.F.
- C.6. 50 P.F.
- C.7. 100 P.F.
- C.8. 0.1 mfd. T.
- C.9. .01 mfd. T.
- C.10. .01 mfd. T.
- C.11. 50 P.F.
- C.12. 50 P.F.
- C.13. .0001 mfd. T.
- C.14. .01 mfd. T.
- C.15. .001 mfd. T.
- C.16. .02 mfd. T.
- C.17. .01 mfd. T.
- C.18. .01 mfd. T.
- C.19. 2 mfd. E.300 v.w.
- C.20. 50 mfd. E.12 v.w.
- C.21. 50 mfd. E.12 v.w.
- C.22. .35 mfd. T.
- C.23. 16 mfd. E.450 v.w.
- C.24. 16 mfd. E.450 v.w.
- C.25. 16 mfd. E.450 v.w.
- C.26. 8 mfd. E.120 v.w.
- C.27. .02 mfd. T.5000 v.w.
- C.28. 0.1 mfd. 400 v.w.T.
- C.29. 0.1 mfd. 400 v.w.T.

VARIABLE CONDENSERS

- T.C.1. 30. P.F. R.F. Grid Coil Trimmer
- T.C.2. 30. P.F. Osc. Tuning Preset
- T.C.3. 20. P.F. I.F. Trimmer
- T.C.4. 20. P.F. „ „
- T.C.5. 25. P.F. Osc. Tuning Sound
- T.C.6. 30. P.F. I.F. Trimmer

VALVES

- V.1. AC/TH1. Mazda. Frequency Changer
- V.2. VP4.B. Mullard. I.F. Amplifier
- V.3. TDD4. Mullard. Detector, A.V.C. Rectifier and Audio Amplifier
- V.4. PEN.A.4. Mullard. Pentode Output Valve
- V.5. IW4/350. Mullard. H.T. Rectifier
- V.6. H.V.R.2. Mullard. E.H.T. 5,000v. Rectifier

COILS

- L.1. Aerial Coupling Coil
- L.2. R.F. Grid Coil
- L.3. 1st I.F. Coil 2.5 m/cs.
- L.4. R.F. Osc. Transf. Secondary
- L.5. R.F. Osc. „ Primary
- L.6. 2nd I.F. Coil. 2.5 m.cs.
- L.7. Audio Output Transformer Primary
- L.8. Audio Output Transformer Secondary
- L.9. Smoothing Choke. H.T. Supply
- L.10. 4.v. A.C. Rectifier Heater Winding
- L.11. 330-0-330. V.A.C. Rectifier Secondary Winding
- L.12. 20.v. A.C. Heater Winding
- L.13. 4.v. 20 amp. A.C. Heater Winding for Sound Time Base and Vision
- L.14. C.R.T. Heater Winding
- L.15. Mains Transformer Primary
- L.16. E.H.T. A.C. Secondary 3,200v.
- L.17. E.H.T. 4.v. Heater Winding
- L.18. E.H.T. 4.v. Heater Winding Primary

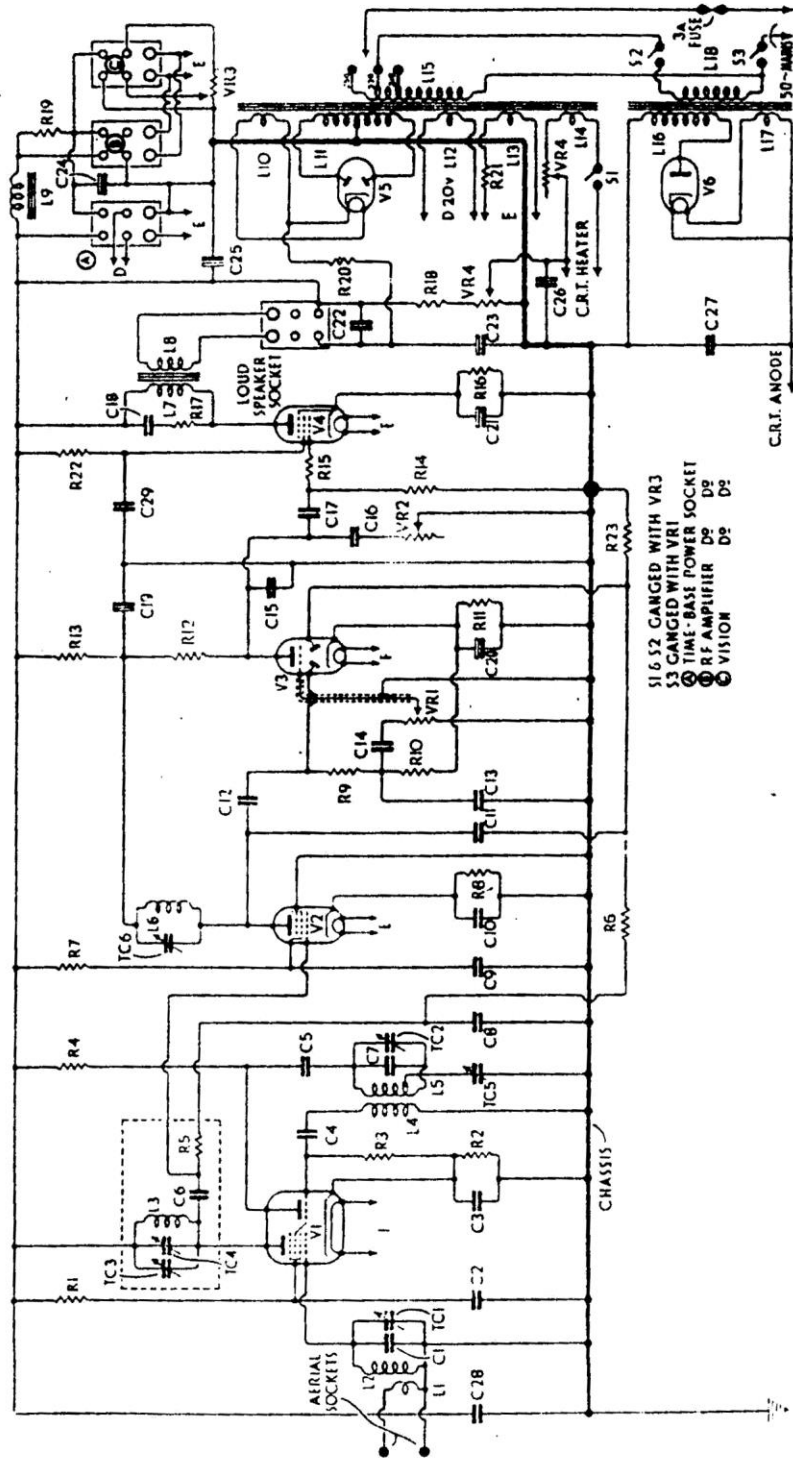

S1, S2 GANGED WITH VR3
 S3 GANGED WITH VR1
 TIME-BASE POWER SOCKET
 RF AMPLIFIER
 VISION

35/6005