

DIAMOND POWER SPECIALTY CORPORATION
INDUSTRIAL TELEVISION EQUIPMENT

Instruction Book for "Utiliscope" Model 300

This equipment provides an indispensable "eye" for hazardous and routine observation.

Important Design Features

1. Long Life and Practical freedom from pick-up failure.
2. Simplicity of circuit
3. Minimized number of tubes
4. Ease of adjustment and set-up
5. Stability and Dependability
6. Non-critical to temperature-change and vibration
7. Portability: compact, and light in weight
8. Safety and convenience
9. 115 volt a-c, 60-cycle, 250-watt operation
10. Master control of camera from Monitor, up to 1000 feet of separation, without use of booster amplifiers.
11. Lens turret for telefocal and ordinary observation
12. Low-cost and low-maintenance

TABLE OF CONTENTS

I DESIGN

1. Factors Contributing to Design
2. Standards
 - 2.1 Scanning
 - 2.2 Resolution and Sensitivity
 - 2.3 Physical Specifications

II DESCRIPTION

III OPERATION

1. Camera
 - 1.1 Lens
 - 1.2 Dissector
 - 1.3 Dissector Coil-System
 - 1.4 Video Preamplifier
 - 1.5 Main Chassis and Case
2. Power Unit
 - 2.1 Power Supply
 - 2.2 Horizontal Deflection and High Voltage Supply
 - 2.3 Vertical Deflection Circuit
 - 2.4 Blanking Mixer and Sync Output
 - 2.5 Chassis and Case
3. Monitor
 - 3.1 General
 - 3.2 Horizontal Deflection and High Voltage System
 - 3.3 Vertical Deflection System
 - 3.4 Sync System
 - 3.5 Power Supply
 - 3.6 Video Amplifier
 - 3.7 Chassis and Case

IV INSTALLATION

V SERVICE NOTES

1. Wave Shapes
2. Voltage Measurements
3. Caution

FIGURES

- Figure 1. Photograph of a resolution chart actually shown on the Monitor
2. Photograph of girl's picture on the Monitor
3. Photograph of complete equipment
4. Block Diagram of Complete Equipment
5. Camera Schematic
6. Power Unit Schematic
7. Monitor Schematic
8. Photograph of the Dissector, Type D30LL
9. Dissector response curve
10. Service photograph of Dissector Coil Assembly
11. Service photograph of camera preamplifier (Bottom view)
12. Schematic of camera preamplifier
13. Frequency response curve of camera preamplifier
14. Multiplier Saturation Curve
15. Service photograph of power unit (Top View)
16. Service photograph of power unit (Bottom View)
17. Photograph of Horizontal deflection transformers (Power Unit and Monitor)
18. Service Photograph of Monitor (Top View)
19. Service Photograph of Monitor (Bottom View)
20. Monitor Video-Amplifier Response Curve
21. Installation Diagram
- Appendix 1 Specifications
- Appendix 2 Wave Shapes

I
DESIGN

The design of the U-300 was undertaken to provide an industrial television system of great serviceability in field operations.

1. FACTORS CONTRIBUTING TO DESIGN:

The "Utiliscope" was designed for industrial uses after careful evaluation of the following factors:

1. Simplicity of operation
2. Dependability
3. Freedom from service requirements
4. Life
5. Performance
6. Cost
7. Portability

The proper evaluation of these seven factors requires that each factor be compromised in favor of all the others, in order to arrive at a product which is useful in the applications for which an industrial television system is usually employed.

It is necessary to understand that in the present state of the television art there are some things which can be accomplished easily by means of television, but some things can be accomplished only with great difficulty.

A Television system is an electro-optical device. In optical devices the combination of high resolution, high sensitivity, broad spectral-response, and exact contrast range are incompatible unless at the expense of extreme complexity, high cost, operational difficulties, constant maintenance, and bulkiness. In electronic devices the service problems are

proportional to the number of tubes, the number of components, the complexity of circuit functions, and the limitations of operating conditions, including: temperature, vibration, stability of adjustment and portability.

Consideration of all of these facts, indicates that the use of a cold-cathode pick-up tube of rugged construction, long life, high signal-level, and non-critical adjustment would be preferable to a short-lived, critical tube of higher sensitivity and greater resolution.

The Farnsworth Image Dissector is the only cold-cathode tube which meets these requirements. At the same time, this tube lends itself to great simplification of circuit arrangement.

Accordingly, the Dissector was chosen as the basis of the "Utiliscope" system. Some dissectors have been in operation for more than ten years. All dissectors are guaranteed for one year (except for mechanical damage) either in continuous or intermittent operation. There is actually nothing to wear out in a cold-cathode tube, and nothing critical about the adjustment. The tube is rugged in construction; but it can be mechanically damaged, since it is made of glass structure. Rate-of-leakage tests indicate that the vacuum in the dissector is good for at least 15 years, before any noticeable deterioration in performance should be encountered.

The choice of the Dissector allowed many circuit simplifications such that only seventeen (17) vacuum tubes (including the Dissector and a 10" cathode-ray viewing tube) are required for operation of the three

units comprising the "Utiliscope". These three units are compact, portable, rugged, and very stable.

1. Camera (3 tubes)
2. Camera Power Unit (6 tubes)
3. Monitor (8 tubes)

The camera may be operated by cable connection up to 1,000 feet from the Monitor. This equipment may be turned on and off day after day, without readjustment, unless changes are made in the optical set-up. In such a case, the adjustment is simple, and can be made by non-skilled operators.

2. STANDARDS

2.1 Scanning:

The "Utiliscope" provides 60 sequential frames per second at approximately 350 lines per frame. The vertical deflection frequency is 60 cycles, synchronized with the power line frequency. The horizontal deflection frequency is 21,500 cycles, approximately, and is not synchronized. The use of interlaced scanning has been avoided as being incompatible with stability, and critical of maintenance.

2.2 Resolution and Sensitivity:

Three hundred (300) lines of television resolution are provided in the vertical and horizontal directions at the center of the picture. 300 foot-candles of scene illumination, either sunlight or 2870° - K temperature of tungsten light is required for a good picture, when using the f/1.4 lens. A usable picture, with a much lower light-level, can be obtained with the equipment under most conditions.

~~This equipment is equally sensitive to integrated, dark light,~~

~~level, can be obtained with the equipment under most conditions.~~

This equipment is equally as sensitive to integrated, dark light, in the near infra-red spectrum, as it is to the integrated light in the visible part of the spectrum. It is sensitive to monochromatic radiation at the same energy level as that of the visible radiation. The spectral response is panchromatic, and peaks between 7000 and 8000 angstroms, as shown in Figure 9.

Contrast in the resolved parts of the image is linear in range and good in quality. An overload control is provided to prevent crushing of the contrast range in cases of excessive scene illumination up to 10,000 foot candles. This corresponds to a manual adjustment of electrical iris, although a simple optical iris (not provided) can be used to secure increased depth-of-focus when high levels of illumination are available.

2.3 Physical Specifications:

- (1) Weight of all units combined is 118 pounds.
- (2) Power consumption is 240 watts at 115 volts r.m.s. 60 cycles.
- (3) Number of adjustments required for usual operation of equipment.
 - (a) Camera, 2
 - (b) Monitor, 3
- (4) Set-up Adjustments
 - (a) Camera, 2
 - (b) Monitor, 6
 - (c) Camera Power Unit, 4
- (5) An f/1.4 5-element lens, having a 90mm focal length is provided. This is a coated lens, with resolution in excess of 20 lines per mm, and is sufficient for

the system.

(6) Tube Complement

- (a) 1 Dissector D30LL (4.5" diameter by 12.5" long, approximately)
 - (b) 1 10FP4 Cathode-ray Tube
 - (c) 4 1B3 GT
 - (d) 2 6L6
 - (e) 2 6AC7
 - (f) 1 5693
 - (g) 1 6J5
 - (h) 5 6SN7GT
- 17 TOTAL

- (7) Equipment will withstand shake-test of plus or minus 1/16" from zero to 300 cycles, or 20-watt audio blast up to 10,000 cycles, with ^{out} microphonic disturbances.
- (8) Ambient temperatures of operation are from 0°F to 150°F if precautions are taken to prevent frosting of optical surfaces.
- (9) Equipment is guaranteed for 8750 hours of continuous operation or one year, including dissector, but excluding receiving-type and cathode-ray tube failure. The 10FP4 cathode-ray tube is guaranteed for six months.

II

DESCRIPTION

Figure 3 is a photograph of the complete equipment. The model U-300 "Utiliscope" is a wired television equipment designed to be used wherever the application requires remote viewing of an object or objects. Figure 1 and 2 show - actual pictures of a test chart and a girl taken from the monitor screen. Appendix No. 1 sets forth the specifications of the complete equipment. Figure 4 shows the complete equipment in block diagram, which includes, for the sending end, a Camera Unit and a Power Unit, and for the receiving end a Monitor Unit.

Referring to Figure 3a, and to the block diagram of Figure 4, the Camera Unit is placed near the object to be viewed. This unit is connected through a single multiple-conductor cable to the Power Unit, which may be separated from the Camera by a maximum of 100 feet, shown in Figure 3b.

The Camera is connected also by a single, multiple-conductor cable to the Monitor, shown in Figure 3c. The monitor may be separated from the camera by a distance of one thousand feet, maximum, without the use of auxiliary signal boosters. The two cables transmit the video signals, the blanking pulses, the sync pulses, and the deflection waves from sending to receiving stations. (One or more cameras and one or more monitors may be used.)

Since simplicity of operation and freedom from service are of extreme importance in the applications for this kind of equipment,

it is felt that the use of single, small-diameter, identical cables is well justified, despite expense.

To understand briefly the operation of the equipment a study of Figure 4 is imperative. Service personnel should become thoroughly familiar with the circuit, principles of operation, and limitations in the use of the "Utiliscope".

The image is focused optically on the cathode of the Dissector (pick-up) tube V201, Figure 5. Horizontal and vertical deflection-power, focusing power and multiplier voltages are supplied to the Dissector from the Power Unit. The video signal from the Dissector collector (output electrode) is fed to an automatic black-level setter, V203a. Blanking pulses are supplied also to V203 from the Power Unit. The television output signal from the camera is amplified by V202 and transferred to the line, through V203b, which matches the line by cathode-follower transformation.

Referring to the Power Unit, schematic, Figure 6, V101 supplies vertical deflection power to the Camera Unit, as well as vertical sync pulses for the Monitor, and vertical blanking pulses. V103 is the horizontal oscillator (known as a "beam relaxor".) This tube supplies horizontal-scanning power to the Dissector, and horizontal blanking pulses to V102. V102 mixes, clips and shapes the horizontal and vertical blanking pulses. The beam relaxor, V103 also supplies horizontal sync pulses to the Monitor. V106 is a cathode-follower which isolates the vertical blanking pulses from the sync pulses, which are fed to the Monitor via cable connections thru the camera.

The beam relaxor supplies high-voltage pulses which are rectified by V104 and V105. These two tubes are in parallel, to provide greater immunity to H-V rectifier failure. Either tube will carry the load alone. The rectifiers supply the multiplier voltages and other voltages to the Dissector, at a nominal level of 2,300 volts negative-to-ground.

In reference to the Monitor, Figure 7, the vertical sync pulses trigger V301 which supplies vertical-deflection power to the cathode-ray tube. The horizontal-sync pulses, from the Power Unit, are amplified by V304 which synchronizes the monitor beam relaxor, V305. This circuit supplies horizontal-deflection power to the monitor tube, as well as high-voltage pulses to V306 and V307. The two rectifiers supply positive potential at a level of approximately 7.5 KV to the picture-tube (anode of the 10FP 4.) The video signal from the Camera is amplified by V302 and V303 before being applied to the grid of the picture tube. A 1N34 is used in the circuit of the DC restorer, to supply proper background brilliance according to the black-level adjustment at the camera.

The U-300 has a standard aspect ratio of 4:3. The resolution of the system is 300 lines, both horizontally and vertically, at the center of the picture, with 300 foot-candles of illumination on the scene.

TECHNICAL SECTION
OPERATION

III
OPERATION

The operation of the various circuits, will be discussed in detail. Figure 5 is a schematic of the Camera; Figure 6 is a schematic of the Power Unit; and Figure 7, of the Monitor.

1. Camera

The Camera consists of five main units as follows:

- 1.1 Lens
- 1.2 Dissector
- 1.3 Dissector Coil-System
- 1.4 Video Preamplifier
- 1.5 Main Chassis and Case

1.1 The Lens

The lens is used to focus an optical image of the object to be viewed on the translucent photo-cathode of the Dissector. This lens is a Miller Optical Company model U-L-3 with a 90 mm focal length and a speed of F/1.4 or better (actually F/1.38.) The lens is coated for 7000 angstrom peak-transmission. The mounting uses a rack-gear and pinion type of focus adjustment. The angle of coverage for a 2" horizontal dimension of image is approximately 32°. The optical focus adjustment will focus on objects as close as 18" in front of the lens, and as far away as infinity. With an adaptor, such as that in the lens housing used on Model 300N, objects as close as 3" can be brought into focus.

1.2 The Dissector

1.21 The Dissector, type D30LL, shown in Figure 8, is a new type of pick-up tube, in that it uses a translucent cathode instead of an opaque cathode, as previously used. Figure 9 shows a typical response curve for this type of Dissector. The peak sensitivity is in the near infra-red portion of the spectrum.

1.22 Photo-Cathode

The cathode connection is brought out to a cap connector (which is painted yellow) on the front of the tube, at one edge of the window. Directly behind the cathode there can be seen five, concentric rings. Each ring is brought out through a terminal to the front of the window, and these terminals are numbered in the order of placement of the rings behind the cathode. Immediately behind the five rings is a nickel wall

coating on the anode. There is an overall voltage between cathode and anode of approximately 400 volts. The rings are connected to a voltage divider between the cathode and anode and have various potentials between them as shown in the circuit diagram of Figure 5. The purpose of these rings is to improve the shape of the electric field in the vicinity of the cathode and decrease the amount of "S" distortion.

1.23 Multiplier

An eleven-stage multiplier is mounted at the rear of the tube. The electron-signal aperture, which is a 30-mil, square hole, is located on the front side of the multiplier shield. The maximum potential which should be applied between multiplier stages is 200 volts. The gain-per-stage varies with the square root of the stage potential difference. The overall gain (11 stages) is between one million and ten million (at maximum of video overload control with 180 volts per stage.)

1.24 Sensitivity

The photo sensitivity is approximately 20 micro-amperes per lumen. There is approximately 6×10^{-10} amperes of signal-current entering the 30-mil aperture at any instant when the illumination is 20 foot-candles on the cathode. This current is multiplied by approximately 1,000,000 in the electron multiplier, which has an average potential of 180 volts, applied between successive stages, so that the output current from the collector is roughly 0.6 milliamps for picture elements having an illumination of 20 foot candles.

1.3 Dissector Coil System

Figure 10 is a photograph of the dissector coil-assembly. This assembly contains the horizontal-deflection coil, vertical-deflection coil, and focus coil. The features of this coil assembly are listed below:

1. Simple construction
2. Horizontal coil inductance 1.2 mh; horizontal coil resistance 7 ohms
3. Vertical coil inductance 2.5 mh; vertical coil resistance 1 ohm
4. Focus coil-turns 2,900; focus coil-resistance 210 ohms
5. Electron-image magnification approximately 4.5

Referring to Figure 10, the horizontal coil is the inner coil and is approximately nine inches long. The vertical coil is a toroidal coil, approximately one inch long. The wire is wound on a toroidal form. This coil fits snugly on the horizontal coil and is directly behind the focus coil. These two deflection coils are rotated 90°, electrically, with respect to one another. The focus coil is semi-layer wound and is placed directly over the dissector cathode in the coil-assembly housing. The coil assembly is supported by three studs on the front of the focus coil. These three studs extend through slots in the bakelite front plate of the coil-housing and are secured with thumb nuts. The coil assembly can be rotated through the range of these slots to align the picture electrically with the optical picture on the dissector cathode, so that the horizontal dimension of the reproduced picture is in a horizontal direction. The coils have been adjusted properly, and should not have to be readjusted.

1.4 Camera Video - Preamplifier

Figure 11 shows a bottom view of the video chassis, and Figure 12 shows a schematic of this portion of the camera circuit. This preamplifier unit is connected by three plugs and can be removed readily without the use of a soldering iron. The function of this unit is to mix the blanking pulses with the video output signal from the Dissector collector. It provides also a semi-automatic, black-level setting. A composite signal composed of video signals and return-beam blanking signals, is created in this preamplifier, and is applied to the camera-output line (93-ohm transmission impedance) thru a cathode follower.

Referring to Figure 12, V202A is the automatic black-level setting. The operation of this tube is as follows: relatively large, blanking signals are fed to the cathode of V202A in series with the video signal from the Dissector collector, which is developed across R231 in the Dissector-collector load (1,000 ohms.)

The DC voltage developed across the Dissector-collector load resistor, due to random noise in the Dissector, will remain at a constant value. Any light which strikes the Dissector cathode will cause a corresponding increase in collector current, hence an increased negative voltage of the collector. Since more light causes electrons to flow to the collector, the collector becomes more negative with respect to ground as the illumination increases. The video-signal input to the preamplifier is approximately 0.6 volts peak-to-peak, when cathode illumination is 20 foot-candles.

The clipping level of the black-level setter can be properly adjusted by applying just enough positive voltage to the cathode (pin 6) to allow only a very small peak of the blanking pulses to come through V202A. This is accomplished by varying R234 to give the proper potential. R223 is an isolating resistor to minimize the capacitance across the collector load.

Any light on the Dissector cathode will cause a higher negative voltage to appear at the cathode of the clipper, V202A, which makes the diode conduct during the negative, white-level excursion of the blanking pedestal, and creates, itself, a positive pulse at this point of the circuit. No video signal can ever extend below the black-level, where the diode is non-conductive.

Again referring to Figure 12, V203 is used as the video amplifier and has a gain of approximately 18. R224 has been made large to minimize "bounce" due to line surges. Decreasing the value of this resistor will increase the gain; however, if this is done the picture "bounce" due to line voltage surges becomes objectionable. R226 and C205B are inserted in the circuit also to minimize the video "bounce" due to sudden line surges.

V202B is used as a cathode follower to provide a low impedance output for the video line. R222 and R230 have been designed to give maximum linear output without exceeding the tube rating. The gain of the cathode-follower tube, with the line properly terminated is approximately 0.3 (actually a loss.) Figure 13 gives the overall frequency-response curve of the video unit.

1.5 Main Chassis

To understand the operation of the components on the camera main chassis refer to Figure 5, the Camera Schematic. ²¹⁰ P205 plugs into the video unit. The Dissector multiplier voltage-divider is shown in the upper left-hand portion of the schematic. The overall voltage across the multiplier is approximately 2000 volts, or 180 volts per stage. C206 and C207 are necessary to improve the low-frequency response of the multiplier due to the high impedance of the multiplier divider. Without these capacitors, a scene which has a very black area against a white background will be followed by trailers. R202 is the width control. Actually this width control is an overall size-control in that it changes the cathode-anode voltage. An increase in this voltage will decrease the width of the scanned image and also the height of the image. The nominal setting for this control is such that the cathode-anode voltage is 400 volts when measured with a voltmeter having a resistance of 20,000 ohms per volt. The scanned picture is then 2" wide, and this is the correct amount of scan. A greater width of scanned picture will increase the geometrical distortion.

1.51 Video Overload Control

R208 constitutes the video overload control. Actually this controls the gain of a middle stage in the multiplier. Such a control is necessary, due to variations in Dissector tubes, and to extreme light conditions which may be encountered. It will be necessary to operate the multiplier at the maximum gain when the light level is quite low.

Under such conditions, the picture is very noisy. If, however, the light-level is high it will be necessary to reduce the gain of the multiplier; should the gain not be reduced, the last stages of the multiplier will be operating in an overloaded condition. Since this overload problem concerns only the last two or three multiplier stages, the overload control has been used in conjunction with stage #6, which is considerably ahead of the collector.

Figure 14 shows the overload saturation of the multiplier a little more clearly. Referring to the figure, the X coordinate shows the light on the photosensitive cathode while the Y coordinate shows the collector current for varying amounts of light. Curve "A" is a plot of the cathode current, as this varies with light-level. If there is no multiplier saturation, the collector current should follow the same characteristic as does this curve. Curve "C" illustrates the saturation of the multiplier when using 200 volts per stage on a particular Dissector. It will be noted that saturation occurs at a low value of light flux, as determined by a variac-control of the light source, when the line-volts output of variac is only approximately 30 volts. Curve "B" shows the collector current reduced by dropping the voltage between multiplier stage #7 and #6. It will be

noted also that this curve is relatively linear up to the maximum, line voltage from the variac. Referring again to the curve, it can be seen that if the light on the cathode varied between 50 and 100-volt settings of the variac, the actual collector current-change would be only about 0.3 ma. With the gain decreased in stage #6, the collector current change would be approximately 1.2 ma, or four times the normal video output. If the light were to swing between the values obtained with the variac at approximately 20, and 80 or 90, it can be seen that the points which correspond to maximum light on the cathode would be crushed, and the picture would have a washed-out appearance.

If the multiplier is operating in the overloaded condition, the automatic blacklevel setter will not operate properly.

1.52 Camera Magnetic Focus

R232 on the Camera, Figure 5 schematic, is the magnetic focus control. R232 is simply a variable resistor in parallel with the focus coil to provide the proper current through the coil.

2. Power Unit

Figure 15 shows a photograph of the Power Unit with the case removed. The function of the Power Unit is to deliver heater voltage, B voltage, multiplier voltage, scanning power and blanking signals to the Camera Unit. This is done through a single, multi-conductor cable. The Power Unit also supplies vertical-sync pulses and horizontal-sync pulses to the Monitor.

The Power Unit draws approximately 100 watts.

Figure 6 shows a schematic of the Power Unit. An analysis of the various circuits in the Power Unit includes:

- 2.1 Power Supply
- 2.2 Horizontal-deflection and high-voltage supply
- 2.3 Vertical-deflection circuit
- 2.4 Blanking mixer and sync output

2.1 Power Supply

The nominal power-supply voltage is plus 275 volts above ground, after filtering. The a-c ripple voltage after filtering is 0.7 RMS. A bridge rectifier circuit is used which utilizes eight, 200 ma selenium rectifiers. The selenium rectifiers and bridge circuit were chosen for their ability to give trouble-free operation for extremely long periods of time. These rectifiers are operated far below their normal ratings.

2.2 Horizontal-Deflection and High Voltage Supply

A single 6L6 tube operated in a "beam relaxor" circuit is used to provide horizontal-deflection power for the Camera as well as to supply high-voltage pulses to the rectifiers. The beam relaxor is a self-oscillating current - blocking - oscillator, a circuit chosen for its durability and high efficiency. This is a free-running oscillator which operates at a frequency of approximately 21.5 KC. The beam relaxor has a high degree of frequency stability over long periods of time. The frequency is controlled by the adjustable cathode resistor R120. The correct setting of this resistor should be made by setting an external, calibrated oscillator at 21,500 cycles, and coupling this signal in thru the top of the camera to plug P20⁴~~5~~ (green wire) after removing this from the jack X20⁴~~5~~.

The resistor, R120, is adjusted until only one vertical, black bar appears on the monitor raster. This resistor should never be reduced below 25 ohms as that would cause improper operation of the blanking mixer. The cathode pulse of the 6L6 is used to feed the horizontal blanking to the blanking mixer. The control is not critical and will vary slightly from one transformer to another. It should never be necessary to adjust this resistor unless the transformer has been replaced.

Figure 16 shows a close-up of the horizontal-deflection transformer. This transformer consists of a grid-winding approximately 100 turns. The plate winding which consists of 500 turns is wound in pi sections to reduce the capacitance of the winding. The high-voltage winding consists of extra turns connected in auto-transformer fashion to the plate winding. A considerable amount of development went into the design of this transformer, in that it must serve three functions, and these functions are interdependent. The transformer must provide: (1) the proper deflection-power to the Camera; (2) the proper high voltage for the Dissector; and (3) the return time must be slightly faster than the blanking return time, so that the retrace of the electron beam on the monitor will be blanked out. These conditions must be met with satisfactory deflection linearity.

The return time of this transformer is 5.7 microseconds, 12% of the H-deflection period. The positive pulse derived from the horizontal-deflection transformer is rectified by the two 1B3 rectifiers which operate in parallel. This provides a negative voltage of approximately 2300 volts on the high-voltage lead to the camera. Since the current drain very nearly approaches the current rating of a single 1B3, two are used in parallel. This is done as an added precaution against failure of rectifiers in field operations.

2.3 Vertical-Deflection Circuit

The vertical-deflection circuit, which includes the dual triode V101, must supply vertical-deflection power to the Camera, vertical blanking pulses to the blanking mixer and vertical-sync pulses to the Monitor. One-half of the 6SN7 (V101) is used as a blocking oscillator.

The frequency-determining time constant is C104 and R104. This has been selected for 60-cycle operation. The lower end of the blocking-oscillator transformer is returned to the 6.3-volt, heater winding on the power transformer, in order to synchronize the number of pictures per second at 60, which is the power-line frequency. The capacitor C105 on the plate of the vertical oscillator as well as the shielding of leads to the height potentiometer, are necessary items to remove horizontal pick-up which occurs during the retrace

of the beam relaxor. This pick-up will cause "jitter" or a "bounce" in the scanning amplitude.

A resistor, R105, is inserted in the cathode circuit of V101. A positive pulse is developed across this resistor, and is used for blanking and for Monitor synchronization. C106 reduces the horizontal pick-up on this lead. The second section of V101 is used as a conventional, vertical amplifier. R118 is the vertical linearity control, while R119 is the height control. T102 is the vertical-output transformer. This transformer is necessary in order to present the proper plate-load impedance for the vertical amplifier.

2.4 Blanking Mixer and Sync Output

Referring once again to Figure 6, V102 is the blanking mixer. One section of this tube is used to mix the horizontal and vertical blanking pulses while the other section is used as a cathode follower. A positive, vertical pulse is fed to the cathode of the blanking mixer. A negative, horizontal pulse from the beam-relaxor cathode is injected on the grid of the blanking mixer. A very low, plate voltage is used, hence the blanking pulses cause very early plate-saturation of the tube. This causes the base-line of the blanking pulses to be absolutely flat which is extremely important, otherwise at low light levels a shading component will appear.

V106 is a cathode follower to isolate the cathode of the Camera vertical oscillator from the Monitor vertical oscillator. If this is not done a large pulse is fed back to the Power Unit from the Monitor vertical oscillator. This pulse, if applied across the cathode resistor of the Power Unit vertical oscillator, will be slightly out of phase with the cathode pulse generated at the Camera, and will make it impossible to derive a clean vertical blanking-pulse from this point.

3. Monitor

The Monitor is quite conventional and will not be treated in too much detail. The Monitor will be broken down under the following headings:

- 3.1 General
- 3.2 Horizontal-Deflection and High-Voltage System
- 3.3 Vertical-Deflection System
- 3.4 Sync System
- 3.5 Power Supply
- 3.6 Video Amplifier

3.1 General

Figure 17 shows a top view of the Monitor with the case removed. The Monitor is so constructed that the cathode-ray tube and all other tubes may be shipped in place. A small clamp is used to keep the 6L6 tube in its socket. Figure 18 shows a bottom view of the Monitor. All controls are

available from the front. Brilliance, contrast and focus controls are available as "knob" adjustments. Other focus controls are located behind the hinged door on the front panel. A meter is used to indicate proper setting of the width control, for any given line voltage between 105 and 135 volts. This meter can be seen when the door on the front panel is open. The meter has a green shaded area on its face. The width control should be set up so that the scanned raster just completely fills the mask. If the equipment is functioning properly, with the correct amount of horizontal scan, the meter pointer should be somewhere within the green shaded area.

3.2 Horizontal-Deflection and High Voltage System

A 6L6, V305, is used in a circuit identical to that of the Power Unit beam relaxor. This circuit provides horizontal deflection and high voltage for the picture tube. The Monitor transformer, however, is different from that of the camera, as shown in Fig. 17b. Synchronization is controlled by injecting the horizontal-sync pulse from the Power Unit on to the screen of the 6L6 and by properly setting the frequency by means of the variable, cathode resistor, R329. The beam relaxor circuit will remain in sync over a rather large range of the frequency control. As this control approaches one end of its "lock-in" range the picture width will decrease. The proper setting of this control is near the other end of the "lock-in" range. The controls on the Monitor are not too critical; however, after the equipment is set up in

proper fashion, the line voltage should be varied over approximately a 20 volt range with a variac to make sure the Monitor will remain in synchronization, if a variac equipment is available. A slight readjustment of the horizontal sync control should be made to make sure the Monitor will remain in sync over at least this range of line voltage.

Basically the beam-relaxer transformer T303 is similar to the Power Unit beam relaxer transformer, but with the addition of two heater windings for the 1B3 rectifiers. This transformer is designed to match a $2\frac{2}{3}$ millihenry deflection coil. The transformer is also designed to provide 7500 volts for the 10FP4 cathode-ray picture-tube, and the return-time is 5.7 micro-seconds or 12% of the H-deflection period.

The 1B3 tubes are used in a voltage doubler circuit to provide the picture tube with a positive polarity of high voltage. The voltage-doubler circuit was chosen to reduce the operating voltages on the transformer and to provide a more efficient performance where power drain and return-time are of great importance.

3.3 Vertical Deflection System

The vertical-deflection system is very similar to the Camera vertical-deflection system. C303 and R305 are the frequency determining elements. These fixed elements were chosen to hold the oscillator in sync, even when there are large variations of line voltage and other parameters.

3.4 Sync System

The vertical sync from the Power Unit is injected directly into the vertical oscillator.

The horizontal sync is amplified and injected, after a relatively high level of amplification by both sections of V304. The grid, cathode and plate time-constants were carefully chosen for the horizontal-sync amplifier to properly phase the triggering of the beam relaxor with respect to the occurrence of the blanking pulse.

3.5 Power Supply

The Monitor power supply is very similar to the supply used on the Power Unit for the camera, except that the DC output through the filter is 350 volts. The ripple voltage appearing at this point is 0.6 volts RMS.

3.6 Video Amplifier

A two-stage video amplifier is used. V302 is a type 5693, known as a red tube. This tube is the same as the 6SJ7 except that it is of the ruggedized, long-life type. The 5693 is relatively free from microphonics. A 6AC7 is used as the second video amplifier. R314, R316 and C306 are used to reduce "bounce" due to line-voltage surges. Figure 19 shows the overall response curve of the Monitor video system. A 1N34 is used as a partial, D-C restorer.

In the event that a higher value of video amplification is required for any special application, the 5693 tube, V302, may be removed and a 6AC7 may be substituted therefore. This change should result in an increased gain of the order of two-to-one.

IV

INSTALLATION

1. CAMERA

Select a location at which no direct light will fall on the Camera lens. The height of the object being televised determines the distance of the Camera to the object. If it is desired to have the height of the image such that it will approximately fill the Monitor screen, then the distance between object and lens should be about three times the height. The lens should be at the same level as the centerline of the object viewed. See Figure 21.

2. POWER UNIT FOR CAMERA

This unit is installed within 25 feet of the Camera, but not in a position which will interfere with cables or adjustments on the Camera Unit. In case that the Power Unit cannot be located within 25 feet of camera, it will be necessary to use Model 300N, which allows a hundred-foot separation between these units. A 115-volt outlet should be reasonably close to the Power Unit.

3. ILLUMINATION

Install two, swivel light sockets about as shown in Figure 21. Two 150-watt spotlights or one spotlight and one 300-watt flood-light are generally satisfactory. Certain locations may cause reflections from the object right into the Camera lens. If this is so, the offending light must be relocated.

4. CONNECTING CABLES

The cable connections are shown in Table I, page 31. Connect the three units together with the two cables before turning on the equipment.

5. MONITOR

This unit is installed wherever the picture image is desired and at the best viewing level. Do not place the Monitor where random light will fall on the face of the picture tube, as this will decrease the Image detail, and may wash-out the contrast. (The covers, cables and adjustments must be accessible after the Monitor and the Power Unit are in place.)

6. SUPPLY VOLTAGE

Line receptacles are required at the two installation locations, for Monitor and Power Unit, unless a power line is run in the conduit, from the Monitor location to the Power Unit location for remote-control purposes. A receptacle should be placed at the site of the Camera Unit, however, for service work. The Monitor should be free to be moved to the Camera site.

TABLE I
U-300 CABLES

| CAMERA to MONITOR | POWER UNIT to MONITOR | CAMERA to MONITOR |
|-------------------------------|-----------------------------|------------------------------|
| <u>Female Connectors:</u> | <u>Male Connectors:</u> | <u>Male Connectors:</u> |
| X-108 | Coax #2 | Coax #1 |
| X-208 | V-Sync | Video |
| 9 wire Cable | Coax #3 | |
| Pin 1 Ground | H-Sync | Maximum length: 1000 feet |
| 2 Blanking | | |
| 3 B-Plus | | |
| 4 Heater (6.3 V a.c.) | Maximum length: | |
| 5 H-V (-2300 V) | 1000 feet | |
| 6 | | |
| 7 V-deflection Wave | | |
| 8 H-deflection Wave | | |
| 9 Focus | | |
| 10 Heater Return | | |

Length: 25 feet, normal
Can be supplied to 100
feet on engineering advice.

This is necessary when telephone communication is not provided, in servicing the equipment. It is convenient to provide some line receptacles at each location for use with test equipment. The 60-cycle supply voltage may be from 95 to 135 volts. If line voltage varies more than plus or minus 2.0 volts, a regulating transformer should be used to insure optimum performance.

7. ADJUSTMENT PROCEDURE AFTER INSTALLATION

Connect power cables to Monitor and Power Unit, and turn the Monitor switch to "on". Allow to warm up for a period of two minutes. Turn on the lights. Adjust the brilliance at the Monitor, for a visible raster. Adjust the Monitor focus until lines in raster are sharp. Turn on the Power Unit. Allow to warm up for two minutes. Adjust the horizontal-synchronization at the Monitor until horizontal-synchronization of the raster occurs. V sync requires no adjustment. Turn the contrast control knob to the fully clockwise position. Further adjustment will be necessary later. Adjust the video overload control for peak brilliance on the Monitor raster. Place the lens into position for viewing the object illuminated by lights. Adjust the lens focus to an approximate best. Readjust the lens focus, readjust the camera focus. Adjust the Monitor contrast to a desired level.

Adjust the brilliance, and readjust the Monitor focus. Readjust the Camera focus, both optical and magnetic. Adjust the video overload control and then readjust the contrast for best picture.

When changing the video overload adjustment, or the brilliance adjustment, the contrast adjustment should usually be changed also. This adjustment is made in relation to one another, when first setting up; that is, vary first one then the other, going back and forth from one to another until the best picture is obtained.

SERVICE NOTES

1. MAINTENANCE1.1 SAFETY NOTICE

High voltage is used in this equipment and may be dangerous to life if personnel should come in contact with certain parts, or connections. The Operator should use discretion while making adjustments or repairs. Power should always be turned OFF before changing tubes or making any internal adjustments.

1.2 CLEANING

The "Utiliscope" should be cleaned regularly. Dusting and blowing with dry air is recommended. The screen of the Cathode-ray tube should receive the same attention as the Camera lenses. These should be wiped with lens paper, or with a clean, very soft cloth, taking care not to scratch them. The light bulbs at the Camera location should be wiped to remove dust. Check all cables for cuts or damage and tighten all cable connections finger tight. Take the lens off once in a while and examine the photo-sensitive face-plate of the Dissector, to see if this requires dusting.

1.3 TUBE REPLACEMENT

The 15 auxiliary tubes, all except the Camera Tube, the 1B3 and the Cathode-ray Tube, 10FP4, have a life expectancy of 2000 hours. The 1B3 has a life expectancy of 1300 hours. The Dissector has a 10,000 hour life expectancy and the 10FP4 has a 4000 hour life expectancy.

When it becomes necessary to change any tubes, be sure that the power switch is OFF. Remove the tops of the cases, and take care to place the tubes in their correct sockets, and to clip on the plate caps where used. The Cathode-ray tube, altho it has a life expectancy of about six months, may last for years. This tube can easily be replaced with proper precaution in the following manner:

1.31 TO CHANGE THE CATHODE-RAY TUBE

Remove the cover of the Monitor case by removing machine screws, loosen the clamp at the front-end of tube, take socket from base and take off cap on side, remove tube. To reinstall, reverse the above procedure.

1.32 TO CHANGE THE DISSECTOR OR CAMERA TUBE

To change the Dissector tube requires: remove the camera case. Remove the high-voltage caps from the Dissector contacts around the window and remove the tube socket from the Dissector base. Unscrew the rear plate bakelite piece. Remove the Dissector by pulling out through rear end of bakelite housing. Then install the new Dissector by reversing the above procedure.

1.4 CORRECTING TROUBLES

Remove the case (or a portion of case) of the unit suspected to be **causing the trouble**. If there is no smoke or arcing, before any service work is done on this equipment, all cables must be in place and power supplies turned on. The voltages to be found in this equipment are on the schematics. Check all Cathode potentials to see if any tubes are burned out.

1.41 No image, trace or pattern on Cathode-ray Tube

With brilliance control in a full clockwise position. Change V302, V303, V305 and V307 in sequence (on Monitor chassis.) See that the cap and socket of Cathode-ray Tube are in place. See that 10FP4 heater is lighted. If the horizontal trace is present, but there is no vertical scan, change V301. For insufficient raster width at Monitor, check line voltage and horizontal centering, or change V305. For insufficient raster height at Monitor, check the height, vertical-linearity and vertical-centering controls, or change V301.

1.42 Raster correct, but no video

Change V202 and V203 in camera, in sequence, and check the socket on the Dissector base. Check the ring-connectors on the front of the Camera tube. Change V302 and V303 in Monitor. Change V103, V104, V105 (in sequence) in the Power Unit.

1.43 Raster present, no horizontal synchronization

(Steady in vertical direction, but with horizontal tearing.) Adjust the horizontal, synchronization control of Monitor. If this does not clear up the trouble, change V304, V305 in Monitor. As a last resort, change V102, V103 in the Power Unit.

1.44 Image not linear in vertical direction

Turn contrast down, brilliance control up, on Monitor. Check adjustment of height control and vertical-linearity control for equal spacing of horizontal-sweep lines. Adjust height and vertical linearity controls in Camera.

1.45 Image not linear in horizontal direction

Change 6L6 in Power Unit. Change 6L6 in Monitor, **Check** R126 in Power Unit. This adjustment must be made with caution, and may require readjustment of R120. Unless the adjustment is proper, portions of the vertical retrace lines will show thru the picture on the Monitor raster. An oscilloscope connected across the video input terminal to the Monitor will show that horizontal pulses of uneven amplitude are breaking thru the frame blanking level during the frame retrace interval.

1.46 No vertical Synchronization

Change V101 in Power Unit, change V301 in Monitor. Check C302 in Monitor.

1.47 Image lacks brightness

Check high-voltage at Camera, Power Unit and Monitor. Adjust contrast, video overload, and brightness controls. Check Camera Pre-amplifier tubes and Monitor Video tubes. Replace 10FP4.

1.48 Geometrical Distortions

There is always some geometrical distortion in present-day television images. Usually these are of the S-distortion type or key-stone type. S-distortion has been minimized in the "Utiliscope" by introduction of the potential rings in the region of the cathode of the pick-up tube. Unless the corners of the optical image fall between terminals for these rings, a key-stone distortion may be produced. This is because the camera sweep along the diagonal of the image comes too close to the distorted field around the terminals. In general, if the width adjustment at the camera is greater than two inches wide, **the** trapezoidal, or key-stone distortion becomes excessive.

The proper mounting for the Dissector to minimize this distortion is as follows:

Cathode terminal (yellow) must be downward toward bottom plate of camera assembly, and centerline thru cathode terminal (yellow) and silver - Evaporator terminal (red) (see Figure 8) should be about 10° to 15° rotated clockwise from vertical position as viewed from front (window) end of the Dissector.

If the V-coil (Figure 10) is not concentric or is skewed with the H-coil, there will be a key-stone distortion. External magnetic fields, or electric fields of high intensity, can produce distortions in the shape of the raster. Soldering irons, electric clock, motors and transformers are particularly bad in this respect. All magnetic material should be as far removed from the camera as is possible.

1.5 WAVE SHAPES

Appendix 2 attached to this report presents the wave shapes which should be obtained at various points of the Circuit. These wave shapes correspond to the points on the schematic diagrams, as marked. For example, P2 shows an exaggerated wave shape at a point, P2 in the Power Unit. Referring to the Power Unit schematic, Figure 6, the point P2 can be found. Several of these points are indicated also in the photos. These wave shapes shown were taken with equipment in normal operating condition, while viewing an average scene as regards balance of black and white areas.

1.6 VOLTAGE MEASUREMENTS

DC voltage-measurements are shown on the three schematic diagrams. These voltage measurements were taken with a Simpson Model 260, 20,000-ohm-per-volt meter. Voltages were taken under normal operating conditions.

1.7 CAUTION

Considerable design effort has been expended on this equipment. It has been pointed out that many factors are interdependent. Should any trouble occur in the equipment, this trouble should be remedied by finding the source of the trouble and returning the equipment to its proper operating conditions. A trouble which develops should never be corrected by a redesign of any portion of the equipment. This can lead to other troubles, which may be more difficult to find. For example, an incorrect remedy for failure of Monitor vertical synchronization might allow the vertical sync to work properly; but blanking trouble, either in blanking-pulse amplitude or width, might occur.

As an additional word of warning, no work should be done on the Camera Unit with the power turned on, unless the trouble-shooter has broad experience in television, as there are many points which have potentials greater than 2 KV in this unit.

1.8 CORNER CUTTING

If any corner of the picture is dark (shaded) the focus coil is probably out of adjustment on the Monitor. Loosen screws (Figure 18) and rotate, or tilt, this coil until shading is corrected.

General:

1. Number of Units (3)

- 1.1 - Camera Pickup
- 1.2 - Camera Power (Sending end)
- 1.3 - Monitor -(Receiving end)

2. Maximum Separation Between Units

- 2.1 - Camera Pickup Unit to Camera Power Unit: 100 Feet
- 2.2 - Single 17 Conductor Interconnecting cable
- 2.3 - Sending and to Receiving end: 1000 Feet
- 2.4 - Three RG62U connecting cables

3. Operation - Continuous or Intermittent4. Maximum Ambient Temperature

- 4.1 - Camera Pickup and Camera Power Unit: 65°C.
- 4.2 - Monitor: 50°C.

5. Lens

- 5.1 - Miller Optical Company F1.4 (coated) - 90 MM Focal length
- 5.2 - Focus Adjustment 20 inches through infinity

6. Illumination Required

- 6.1 - Minimum object illumination required, about 300 foot candles of sunlight, or 2870° Kelvin tungsten-lamp light.

7. Power Requirements

- 7.1 - Nominal 115 volt AC (60 cycle only)
- 7.2 - Camera Power, 100 Watts
- 7.3 - Monitor Power, 125 Watts

8. All Controls Available From the Front (except clipping level control and camera width-control)9. Available Controls

- 9.1 - Camera Pickup Unit - None
- 9.2 - Camera Power Unit - None
- 9.3 - Monitor Unit - Three
 - a. Focus
 - b. Brilliance
 - c. Contrast
- 9.4 - Monitor Remote Control of Camera - Four
 - a. Lens Focus
 - b. Lens Shift
 - c. Magnetic Focus
 - d. Video Overload

10. Pre-set Controls

- 10.1 - Camera Pickup Unit - Two
 - a. Scan size (width)
 - b. Clipping Level
- 10.2 - Camera Power Unit - Four
 - a. Height
 - b. Vertical Linearity
 - c. Line Voltage
 - d. Horizontal Linearity
- 10.3 - Monitor - Six
 - a. Width
 - b. Height
 - c. Vertical Linearity
 - d. Horizontal Centering
 - e. Vertical Centering
 - f. Horizontal Sync

11. Tube Complement - Total Seventeen

- 11.1 - Camera Pickup Unit - Three
 - a. Dissector - One
 - b. Receiving Tubes - Two
- 11.2 - Camera Power Unit - Six
 - a. Receiving Tubes - Four
 - b. Rectifiers - Two
- 11.3 - Monitor - Eight
 - a. Cathode Ray Tube - One
 - b. Receiving Tubes - Five
 - c. Rectifiers - Two

12. Accessable Plug Termination on Monitor for Video Line13. Each Power Transformer is Fused

Electrical Specifications:

1. Direct Horizontal & Vertical Synchronization of Monitor2. Scanning Frequencies

- 2.1 - Horizontal - 21,500 cycles (free running)
- 2.2 - Vertical - 60 cycles synchronous with power line frequency
- 2.3 - Non-interlaced

3. Aspect-Ratio - 4/3
 - 3.1 Monitor Picture Width - 8-1/4"
 - 3.2 Scanned Image on Dissector - 2 inches Wide Nominal;
1-7/8" minimum
4. Resolution (center of picture)
 - 4.1 - Horizontal - 300 lines
 - 4.2 - Vertical - 300 lines
5. Video Bandwidth - 4MC
6. Video Gain
 - a. Camera - 2 volts
 - b. Monitor - 80 volts
From Dissector to Cathode-ray 160 volts
7. Maximum Overall Scanning Distortion
 - 7.1 - Horizontal - 15%
 - 7.2 - Vertical - 10%
 - 7.3 - "S" Distortion - 10%
8. Design Center Line Voltage - 115 volts
 - 8.1 - Operating Line Voltage Center 105 volts to 130 volts
9. Picture Tube Anode Voltage: 7500 volts Nominal
10. Dissector Multiplier Voltage: 1900 volts Nominal

Mechanical

1. Size
 - 1.1 - Camera Pickup Unit - 9 3/4" Wide x 8 1/2" High x 17 1/2" Deep
 - 1.2 - Camera Power Unit - 9 3/4" Wide x 8 1/2" High x 17 1/2" Deep
 - 1.3 - Monitor - 13" Wide x 16 5/8" High x 20 3/8" Deep
2. Weight
 - 2.1 - Camera Pickup Unit - 47 pounds
 - 2.2 - Camera Power Unit - 37 pounds
 - 2.3 - Monitor - Approximately 60 pounds

3. Mounting Provisions - Shock Mounts
4. Line Power Input Plugs - Locking Type
5. Appearance - Rugged and Reliable but Cost a Major Consideration

Pickup Tube - Translucent Dissector Type D30LL

Miscellaneous

1. Picture Tube - Type 10FP4 (aluminized)

APPENDIX 2

WAVE SHAPES - Page 1

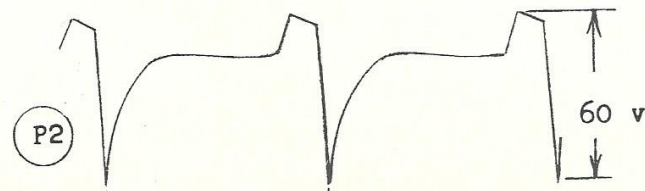
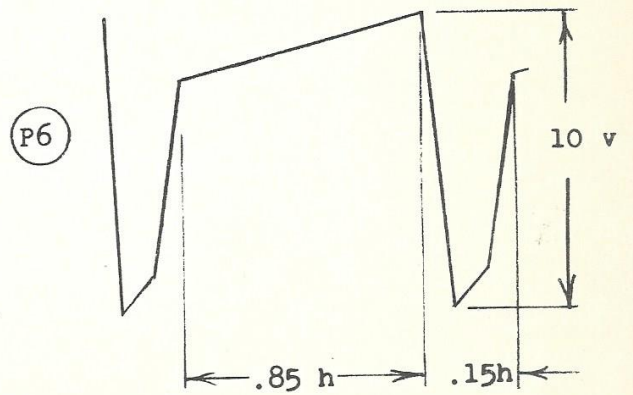
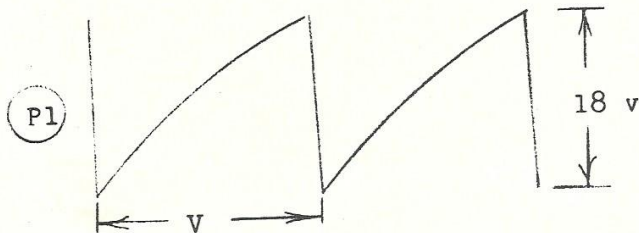
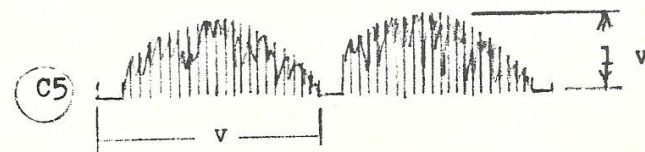
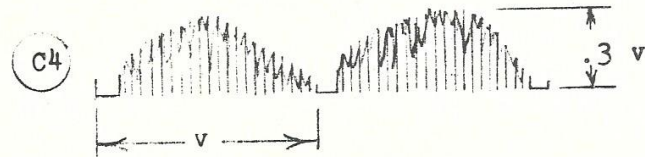
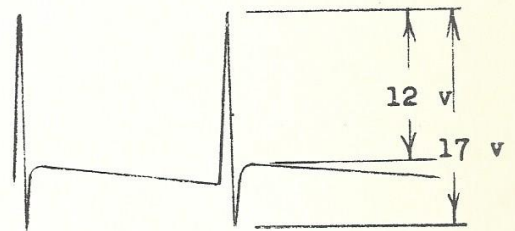
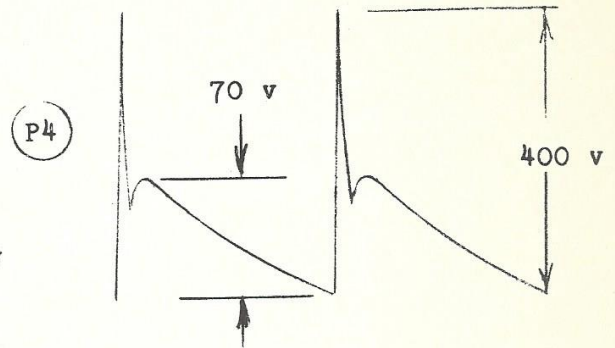
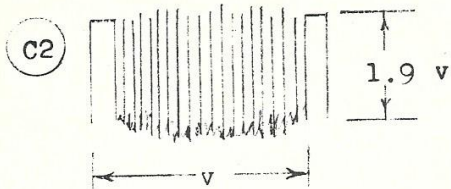
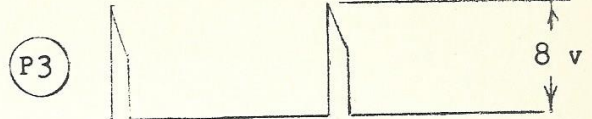
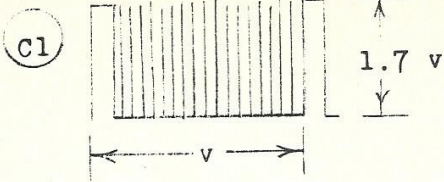

WAVE SHAPES - Page 2

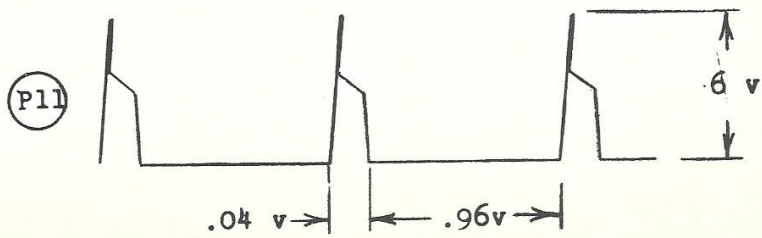
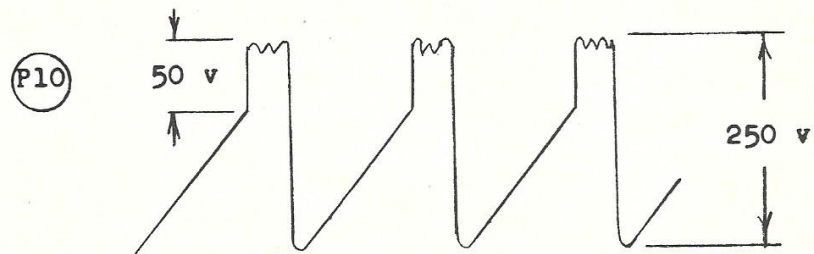
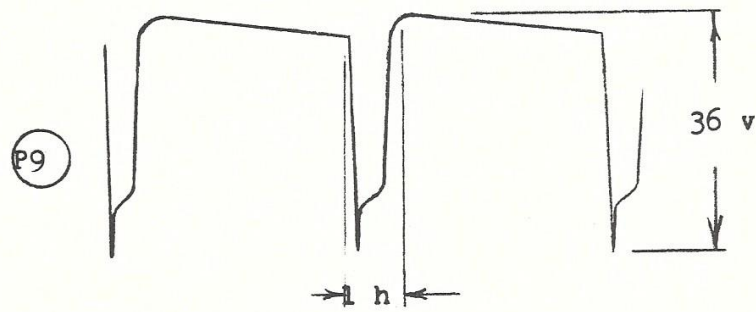
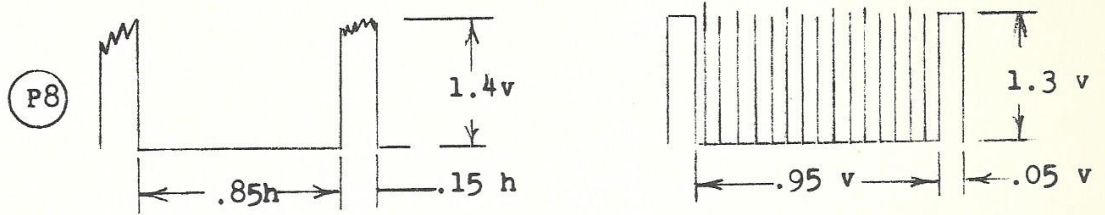
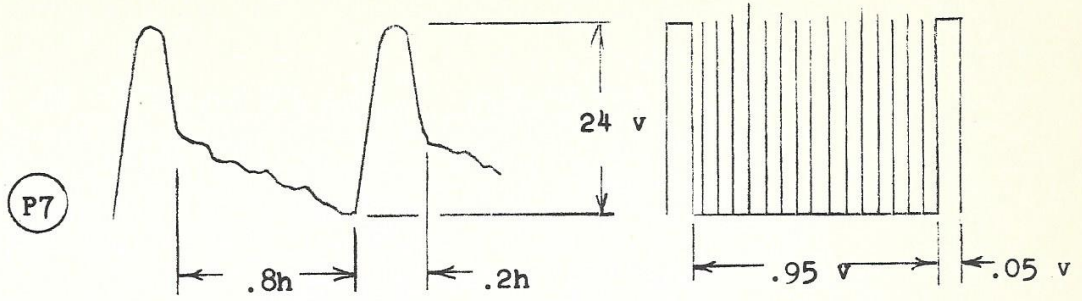

WAVE SHAPES - Page 3

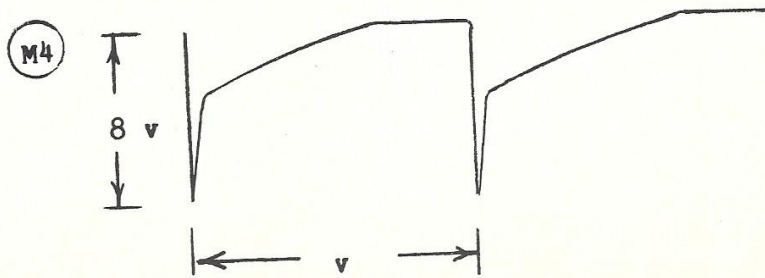
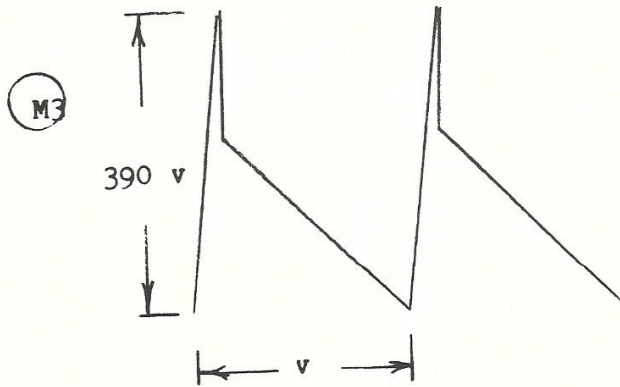
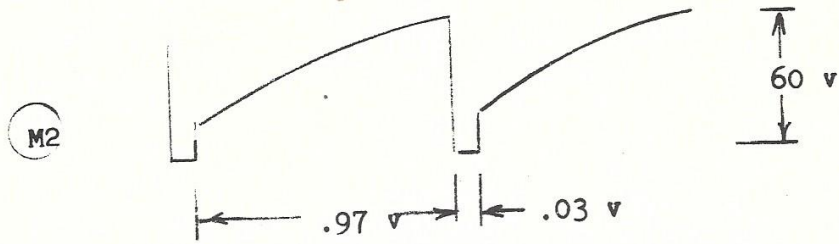
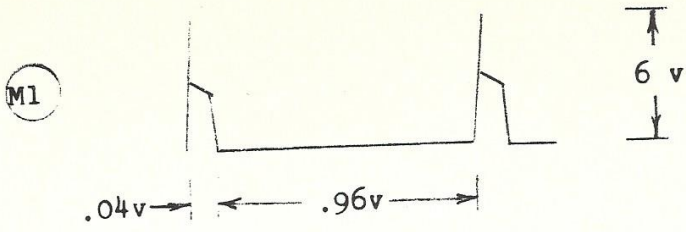

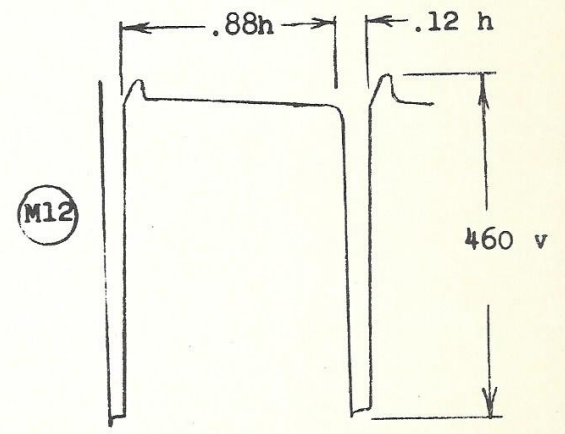
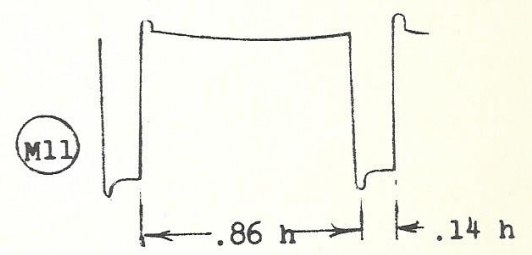
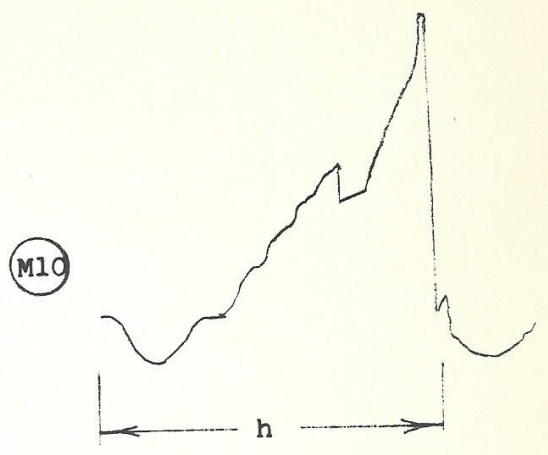
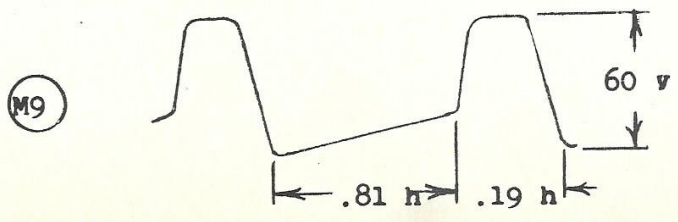
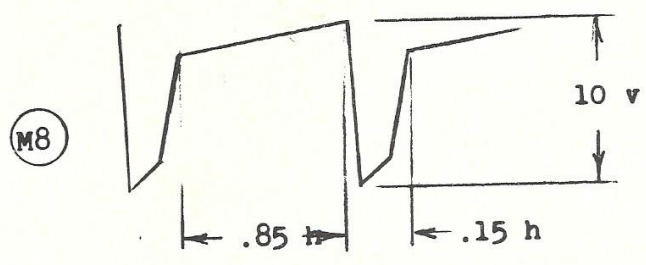
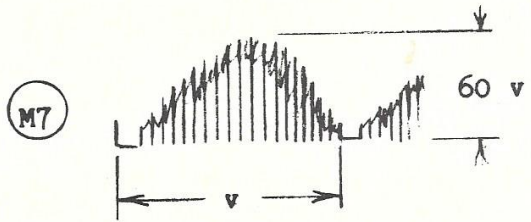
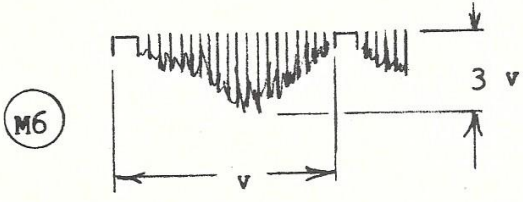
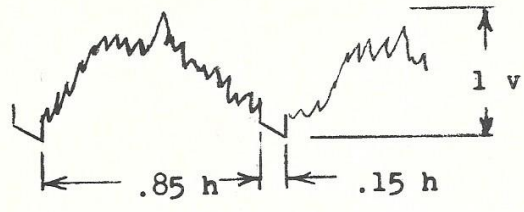
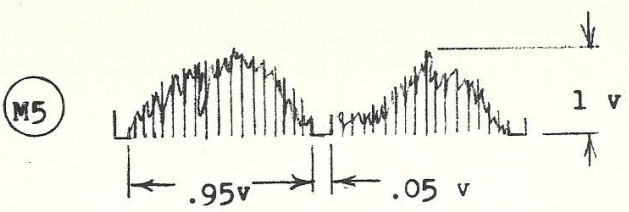

M10

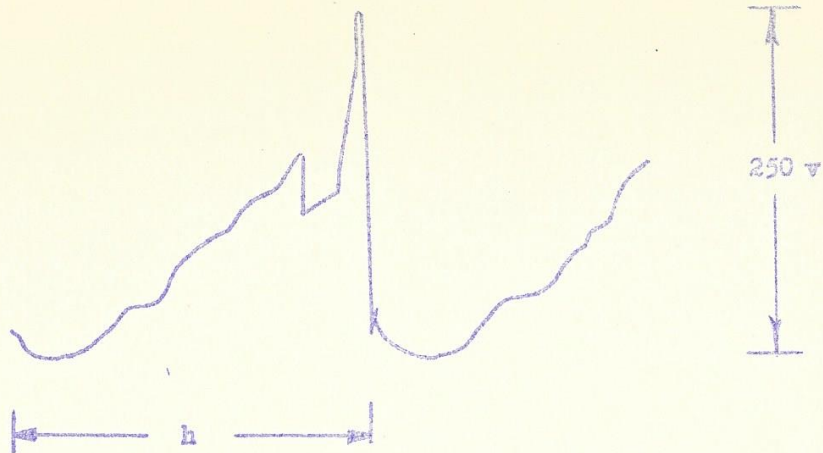

M11

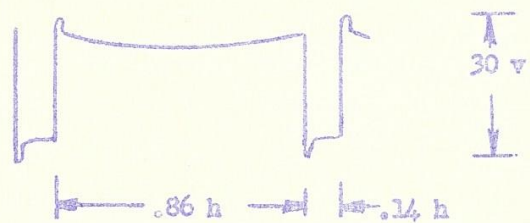

M12

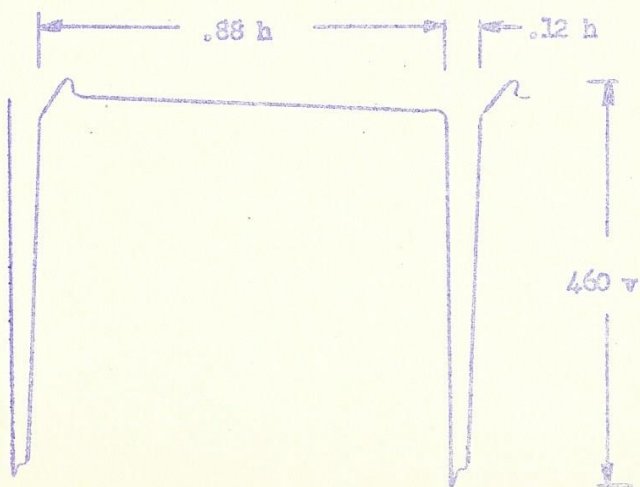

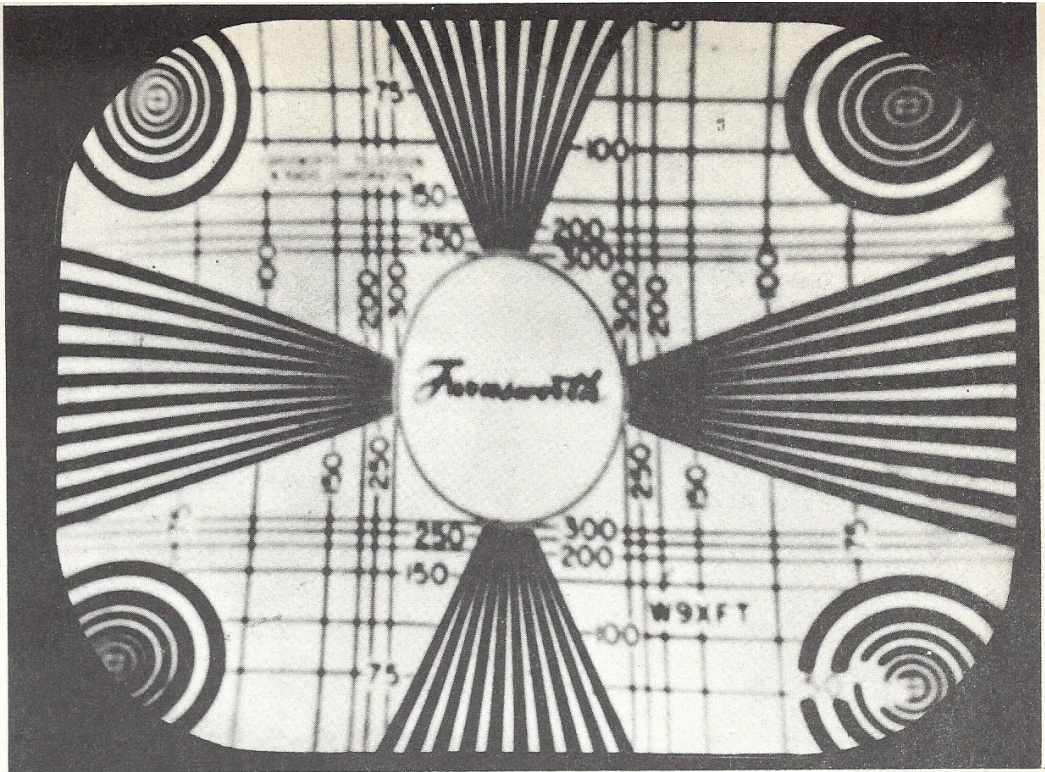
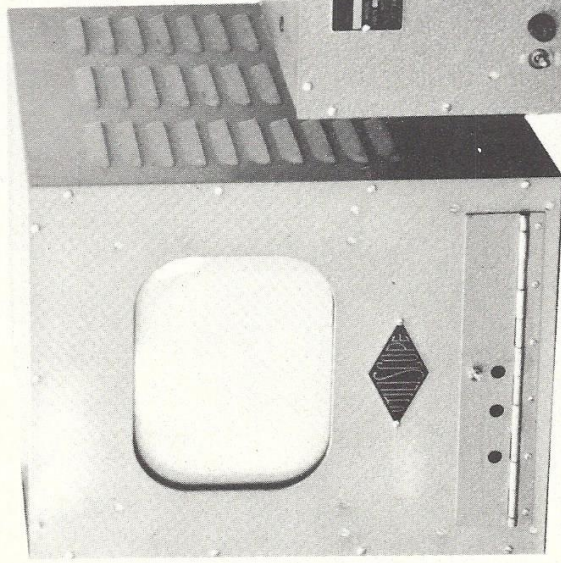

FIGURE 1



FIGURE 2

(C)



MONITOR

(B)

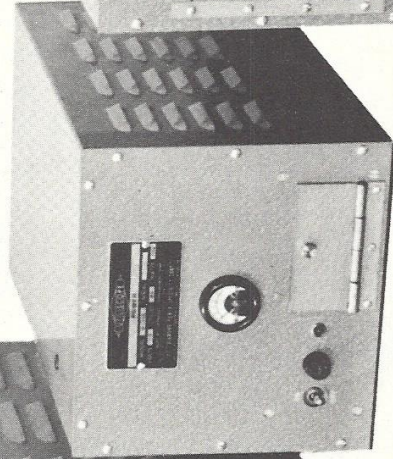

POWER UNIT

(A)

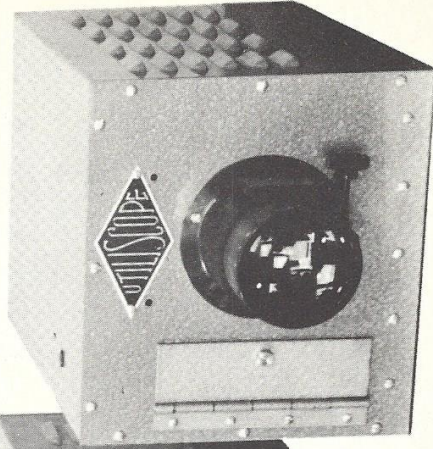

CAMERA

FIGURE 3

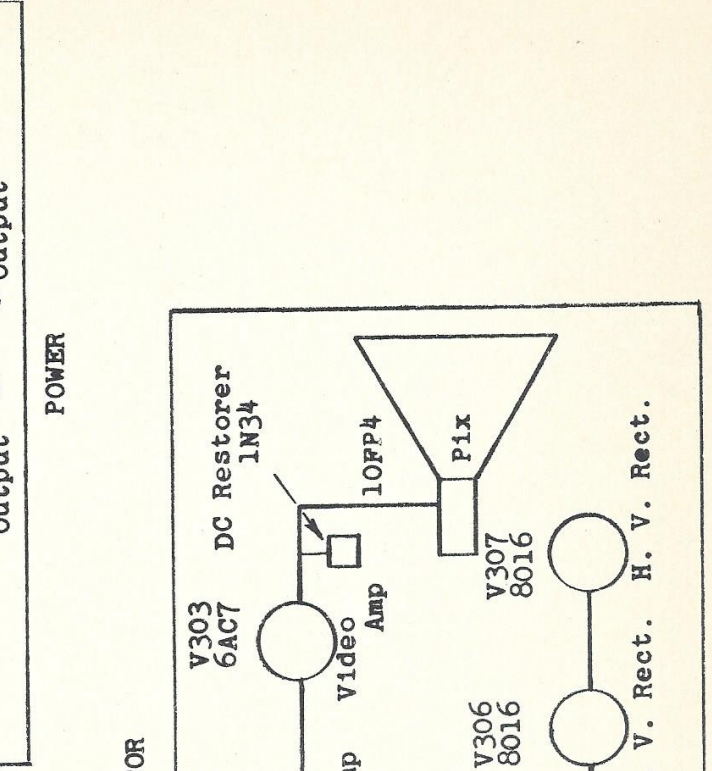
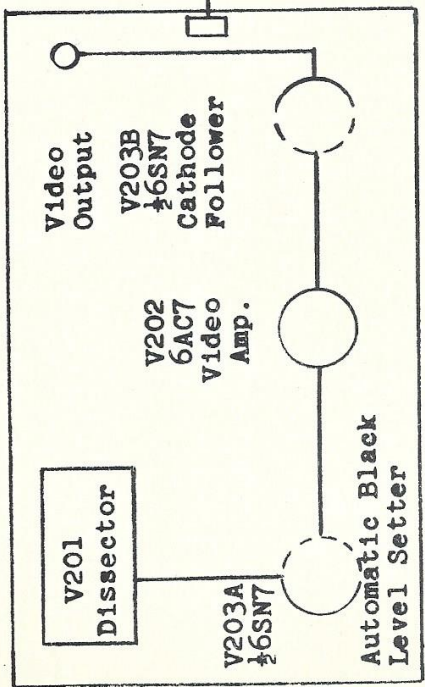
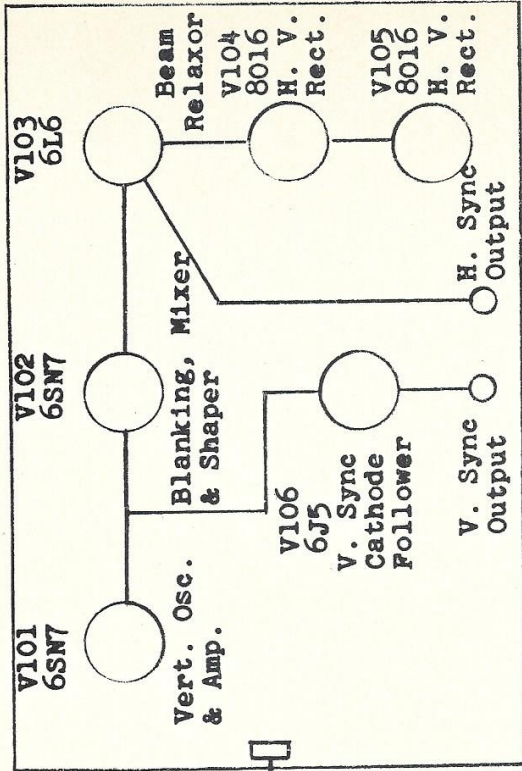

Figure 4

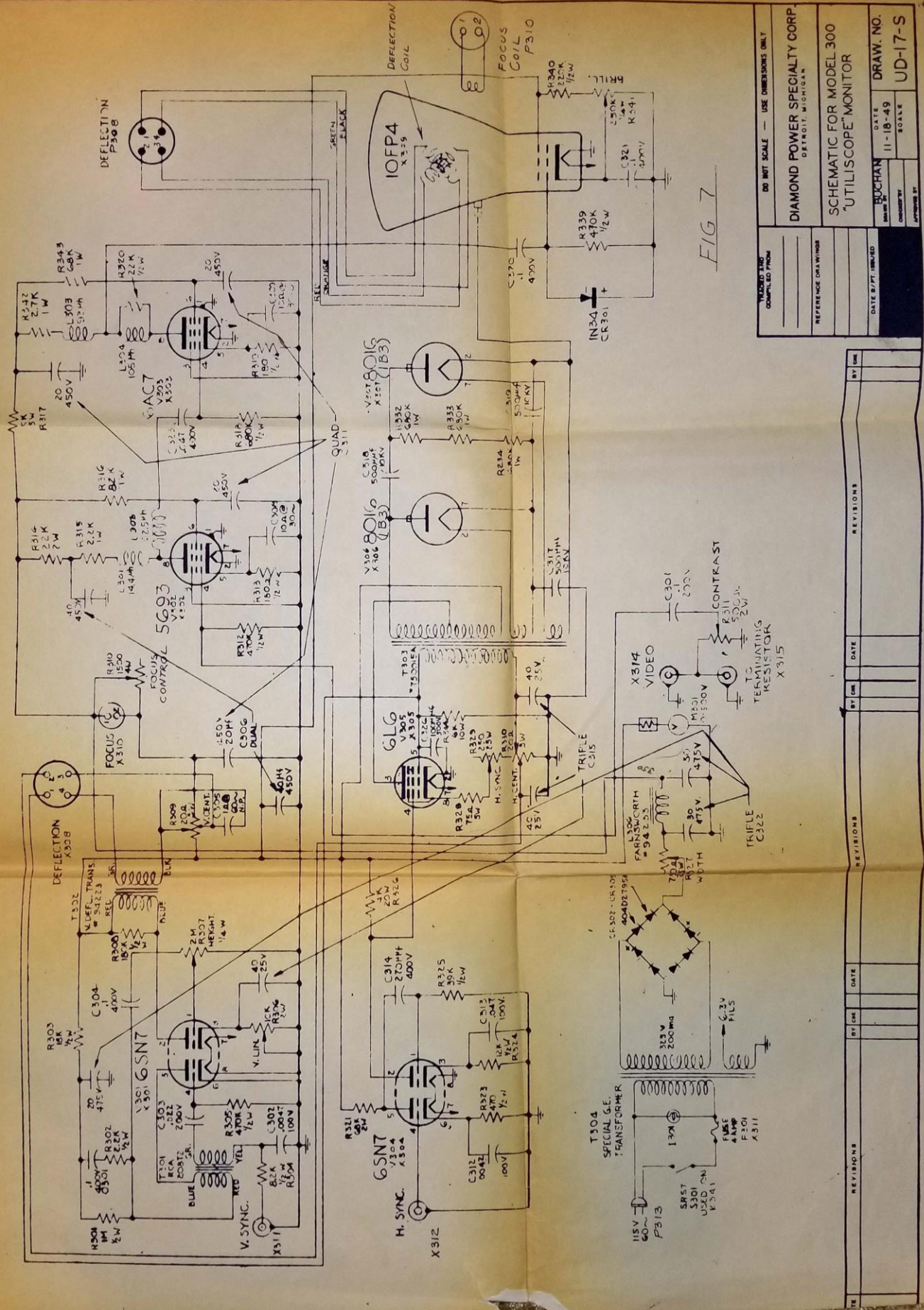

FIG 7

DO NOT SCALE - USE DIMENSIONS ONLY

RECORD THE COMPARED FROM

REFERENCE ORA WITH/MS

DATE B/PT/MS/AD

DIAMOND POWER SPECIALTY CORP.
DETROIT, MICHIGAN

SCHEMATIC FOR MODEL 300
"UTILISCOPE" MONITOR

DATE 11-18-49
DRAW. NO. UD-17-S

| REV. | BY | CHK | DATE | REVISIONS |
|------|----|-----|------|-----------|
| | | | | |
| | | | | |
| | | | | |
| | | | | |
| | | | | |

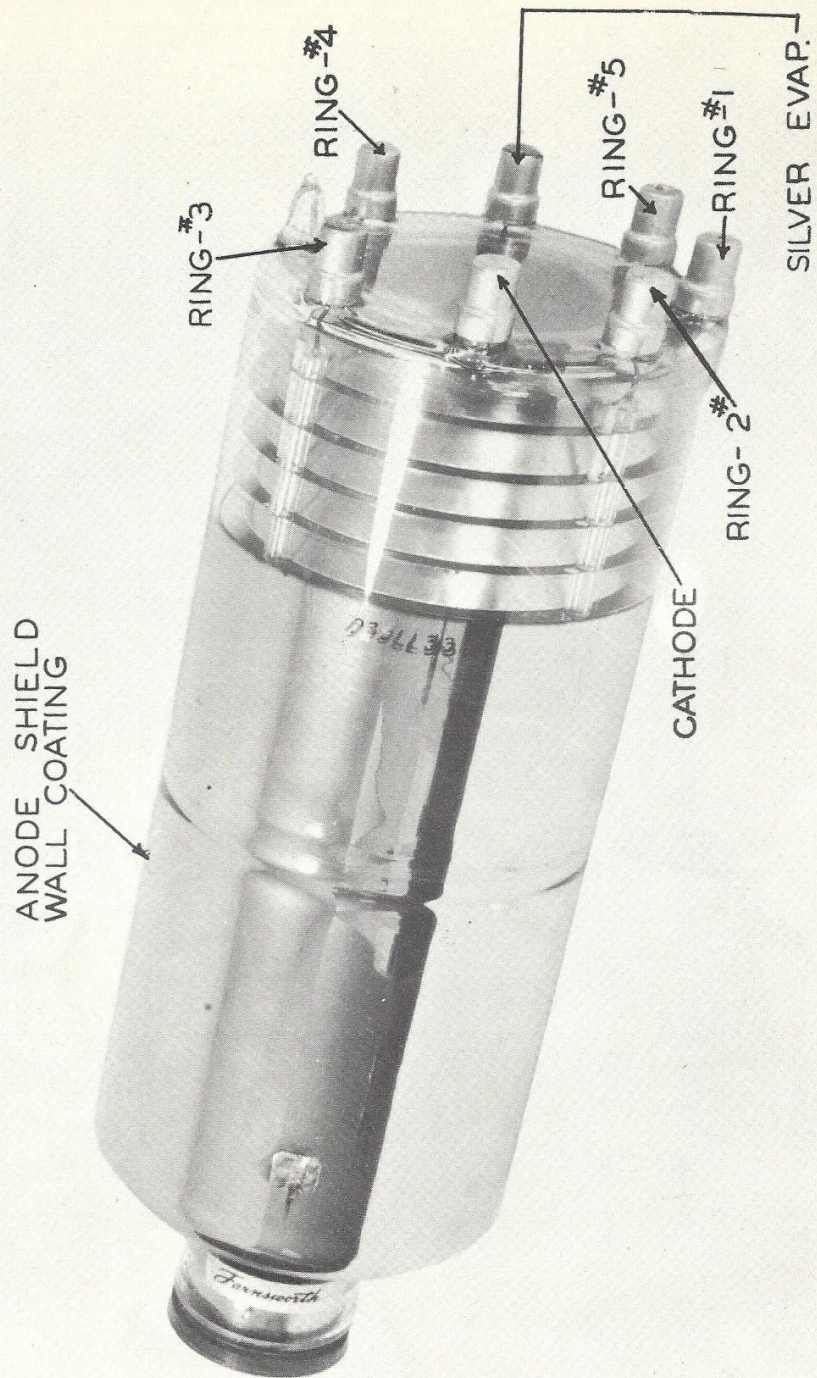
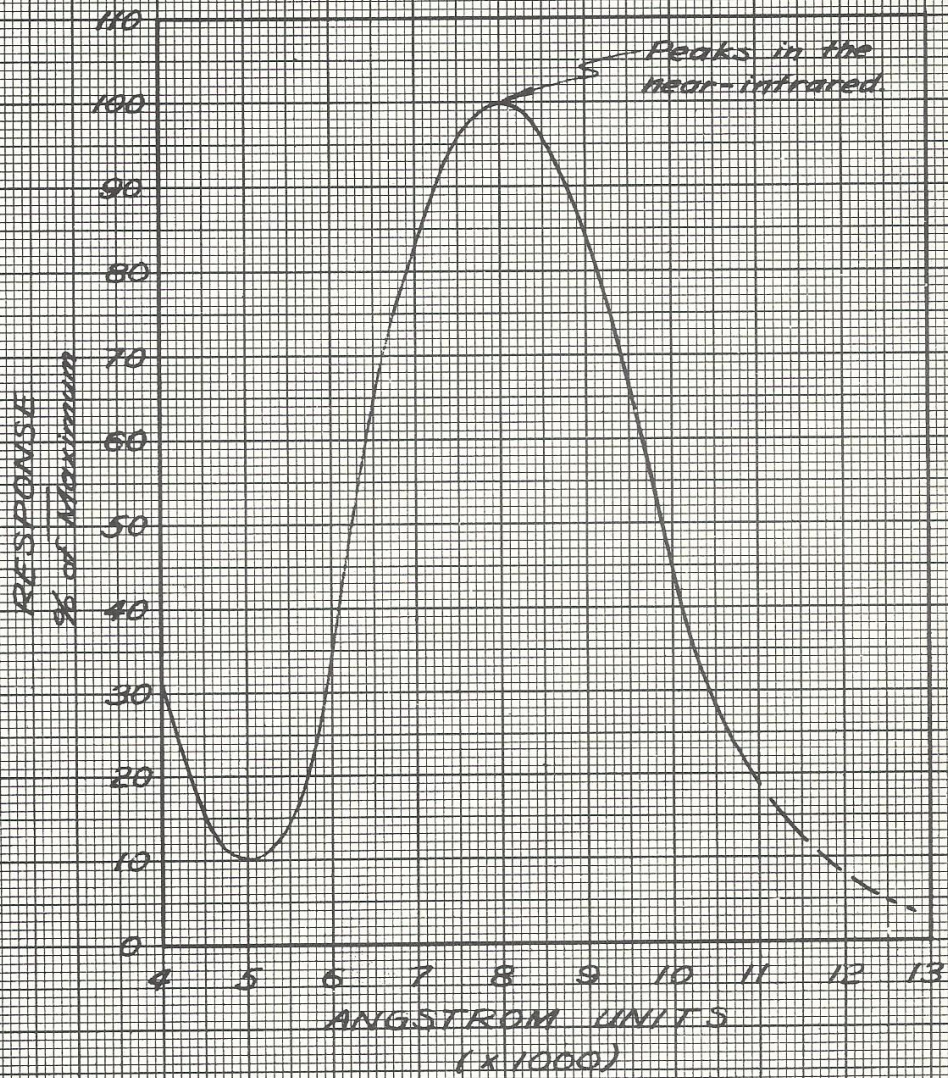
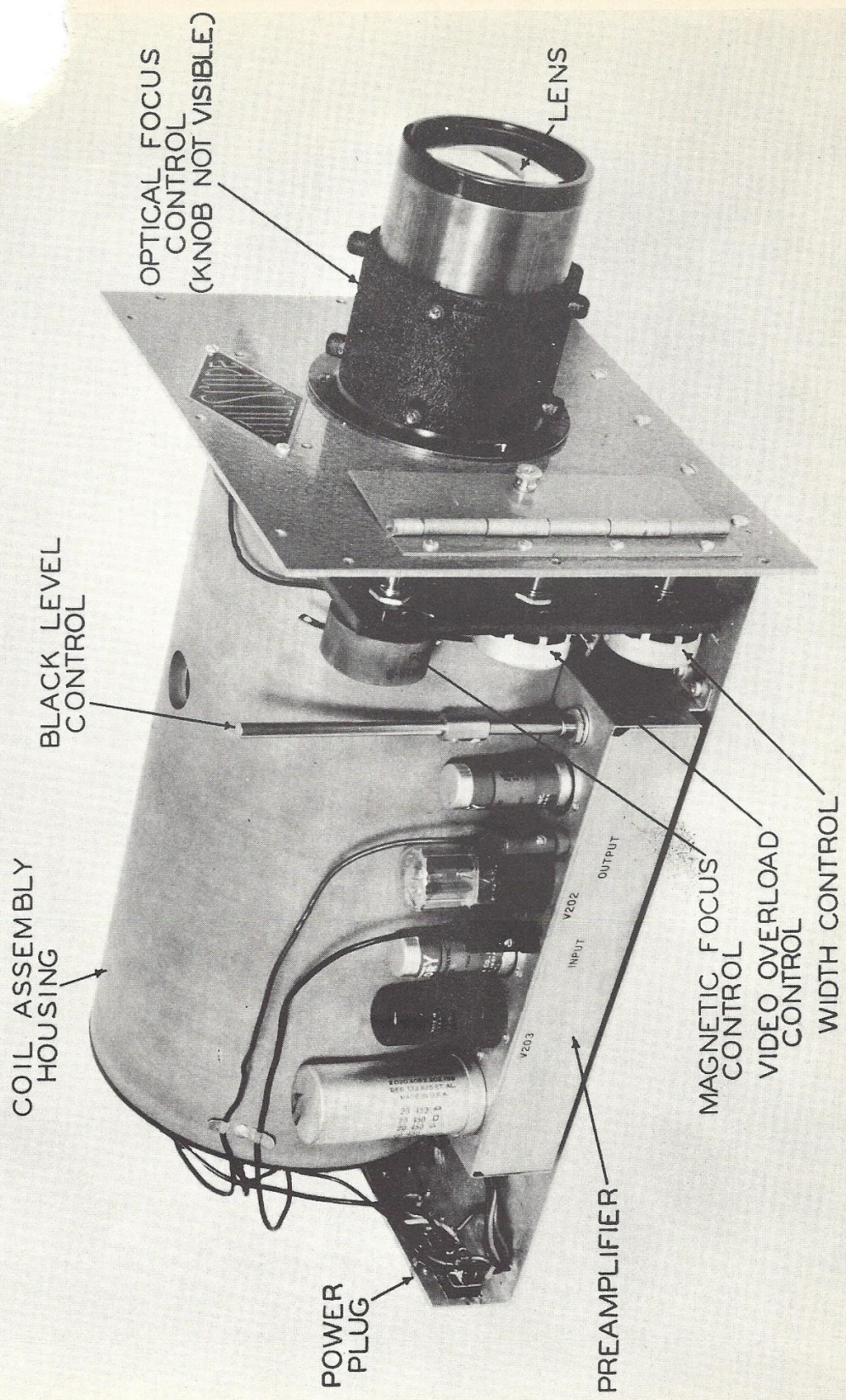

FIGURE 8



SPECTRAL RESPONSE
OF
IMAGE DISSECTOR TUBE

FIG. 9



COIL ASSEMBLY IN CAMERA

FIGURE 10-A

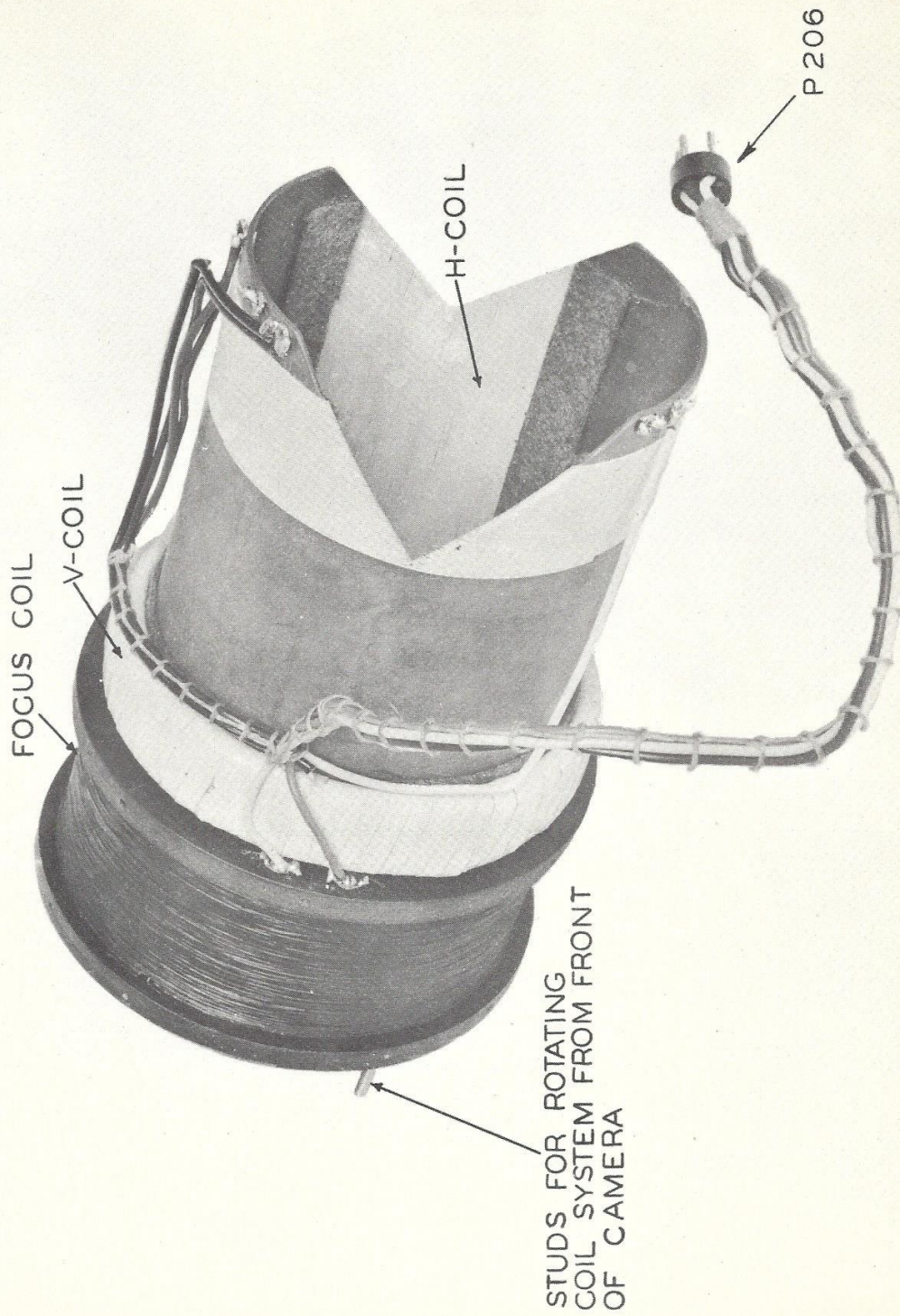
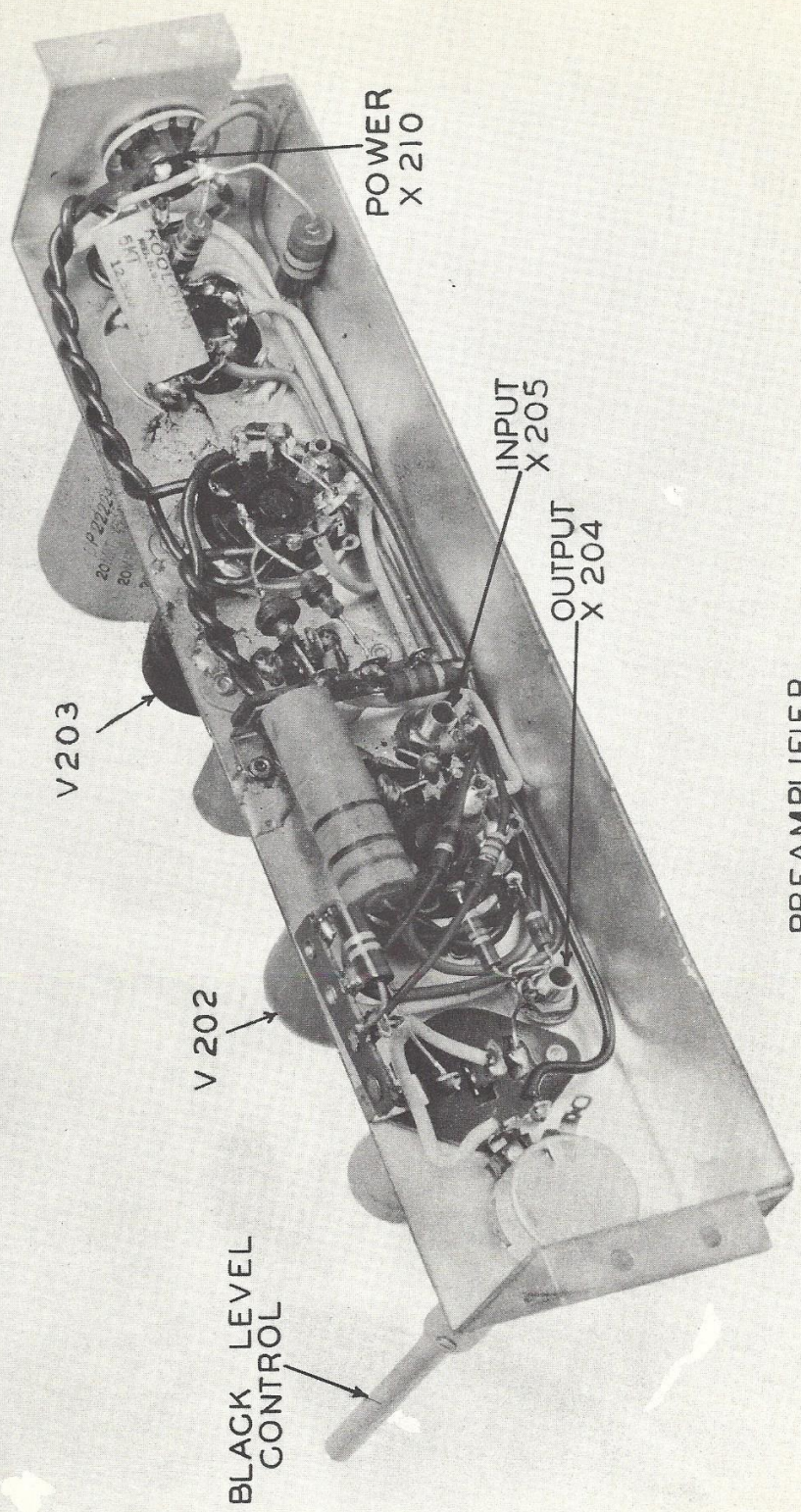
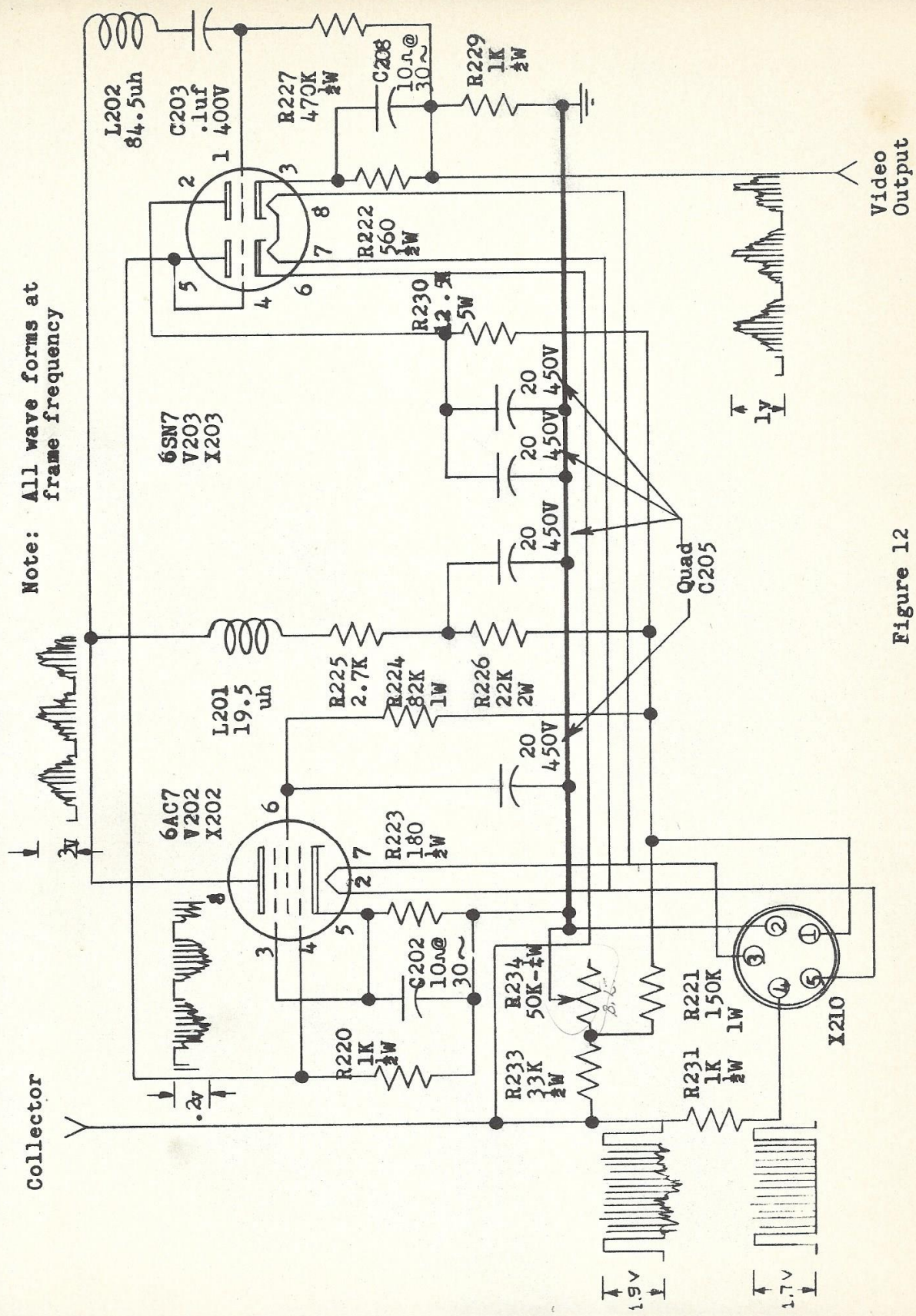

FIGURE 10-B



PREAMPLIFIER

FIGURE II



Note: All wave forms at frame frequency

Figure 12

CAMERA VIDEO AMPLIFIER RESPONSE

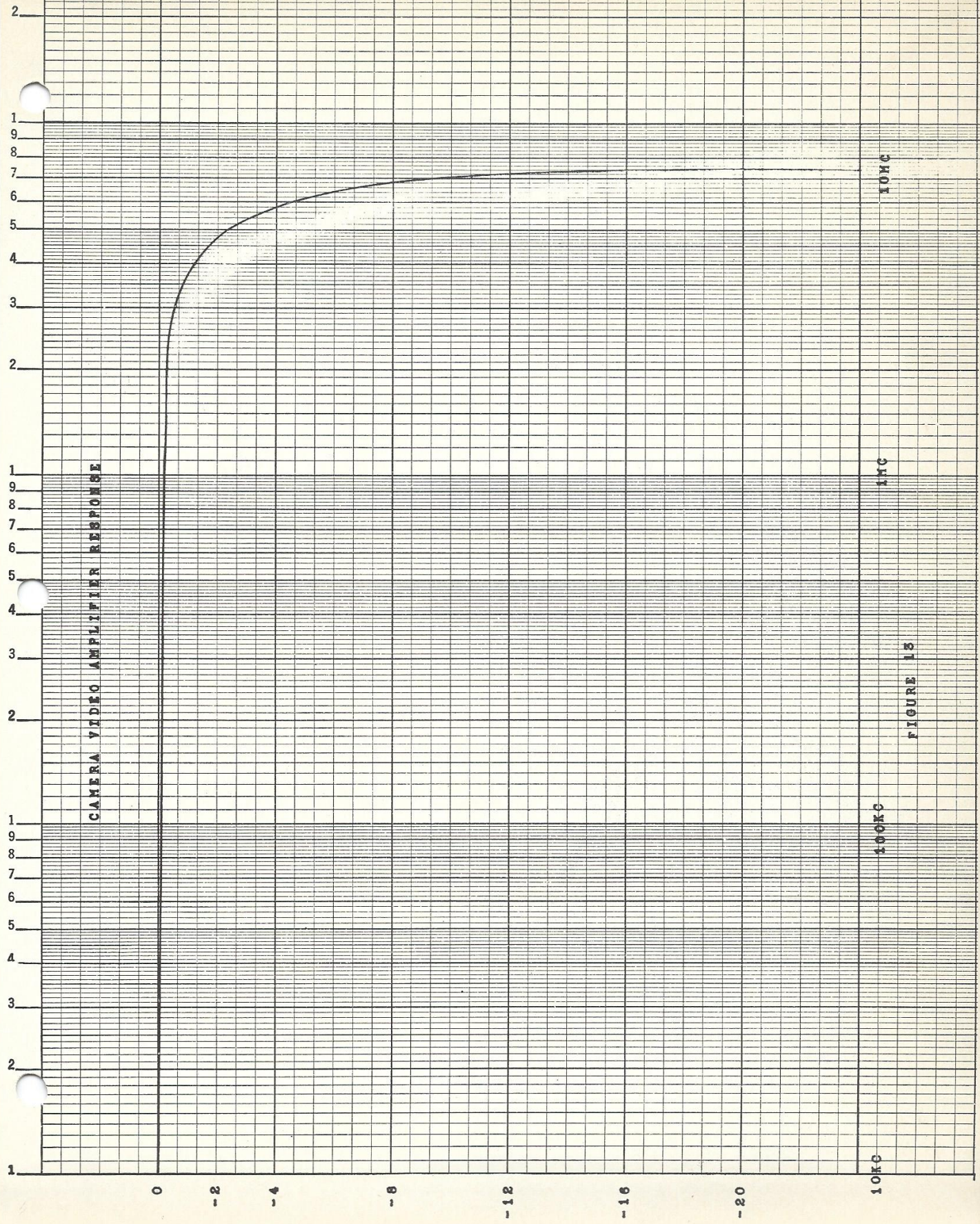

10KC

1MC

FIGURE 13

100KC

10KC

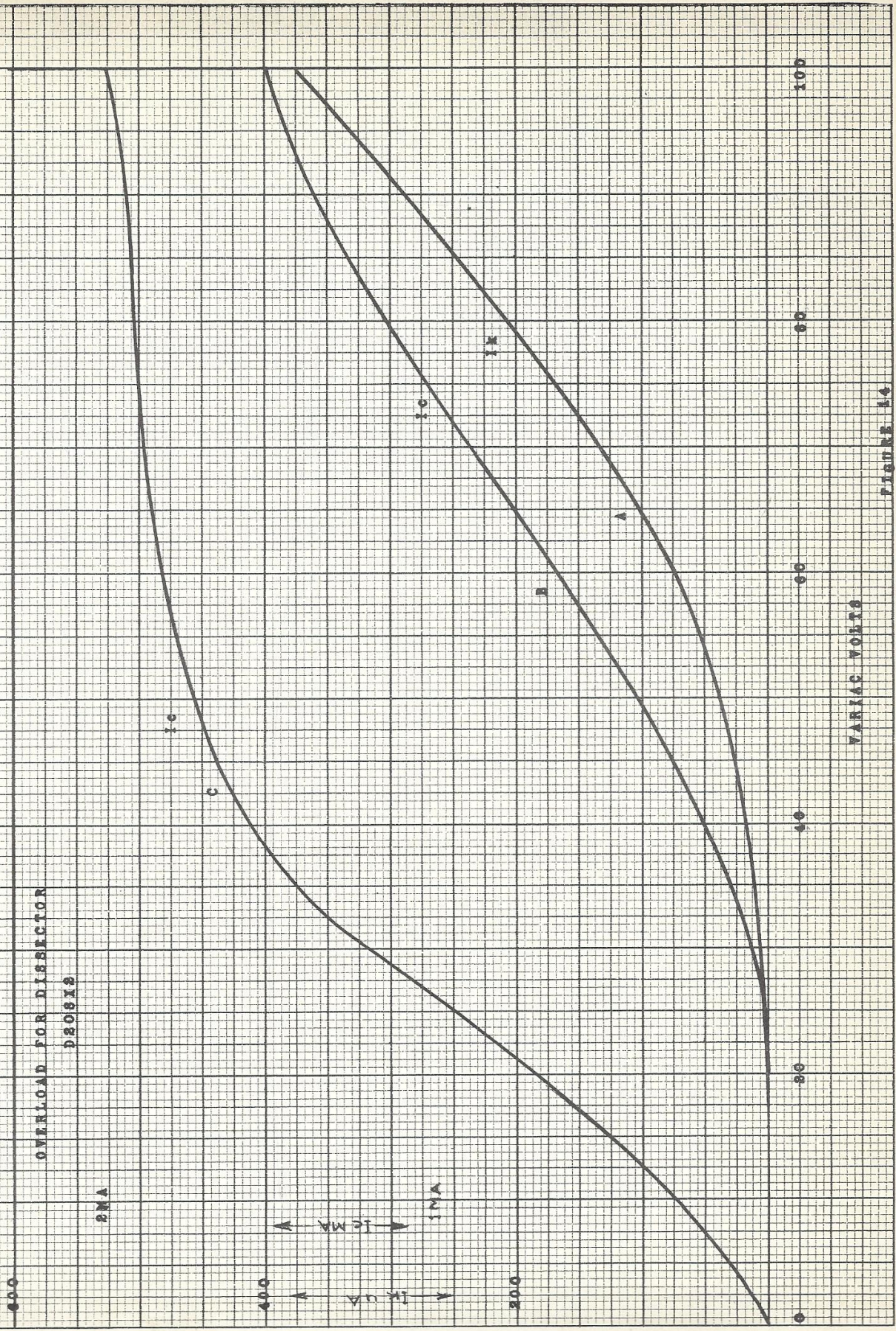

OVERLOAD FOR DISSECTOR
 200X12

2MA

400 V
 100 V
 100 V
 100 V
 100 V

VARIAC VOLTS

FIGURE 14

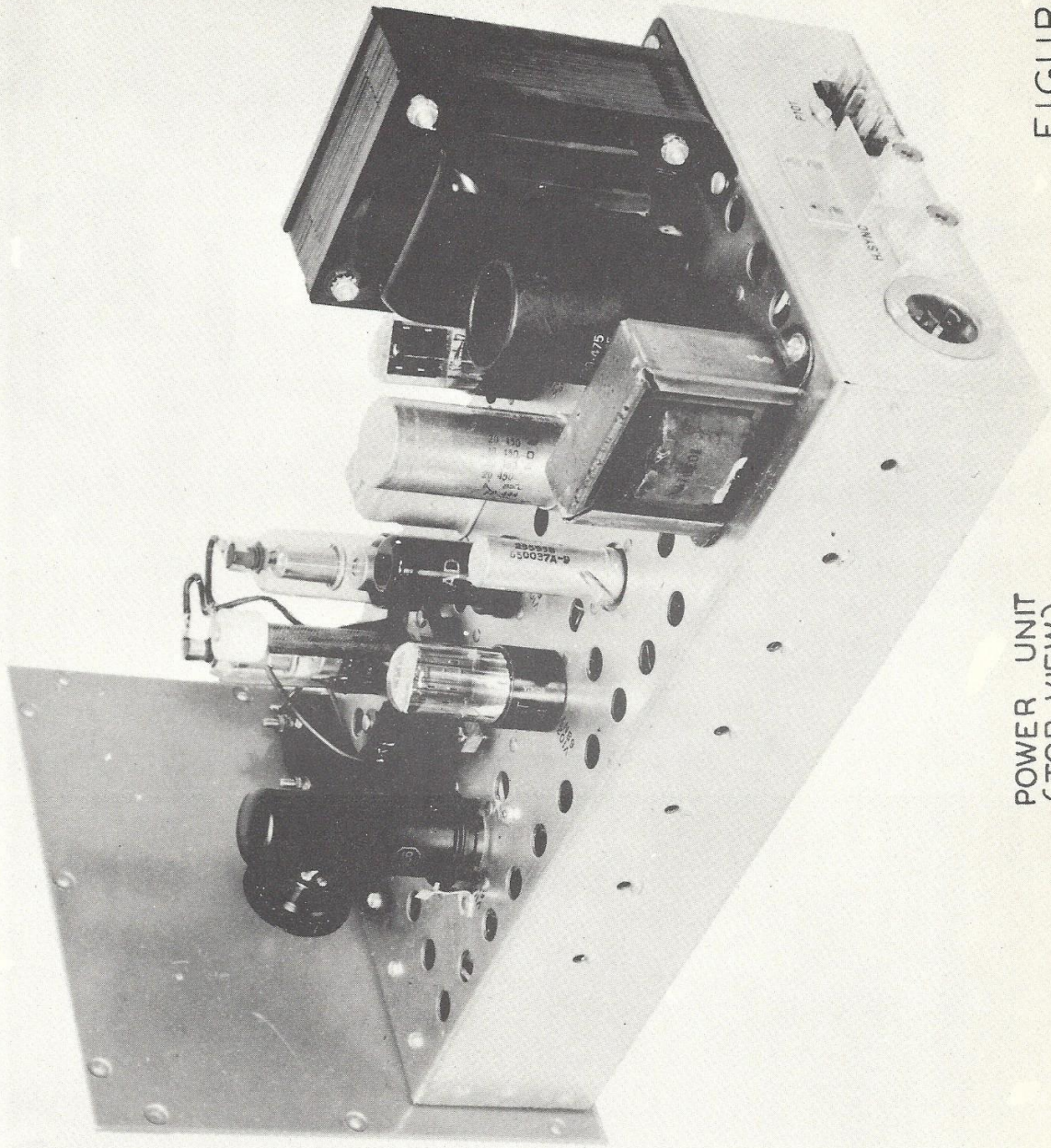

POWER UNIT
(TOP VIEW)

FIGURE 15

B+ (RED TERMINAL)
275V NOMINAL

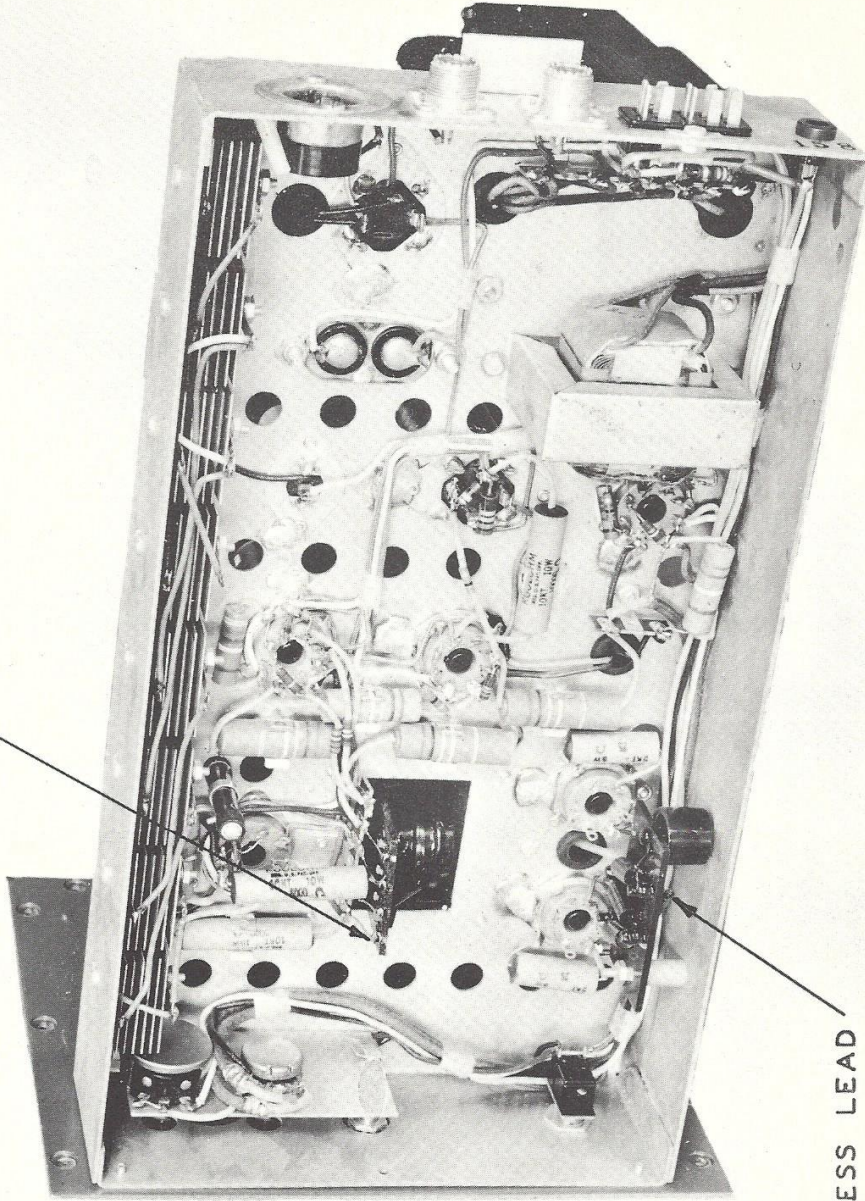

-2300V
COLORLESS LEAD

POWER UNIT
(BOTTOM VIEW)

FIGURE 16

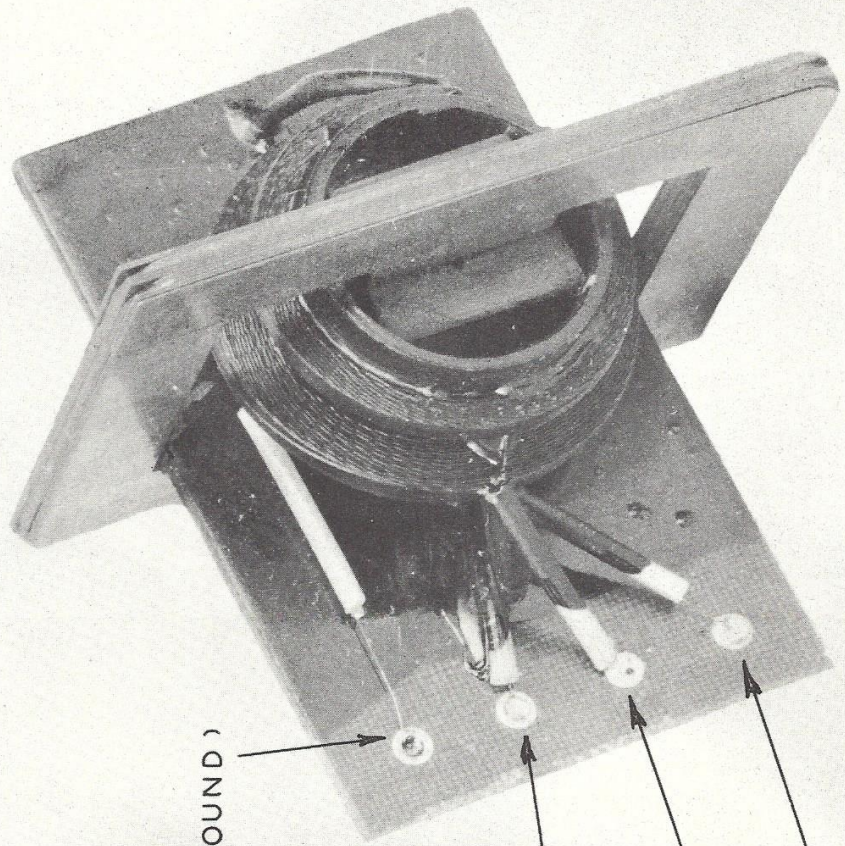

YELLOW (GROUND)

GREEN (GRID)

BLUE (PLATE)

RED (B +)

H-DEFLECTION TRANSFORMER
(POWER UNIT)

FIGURE 17-A

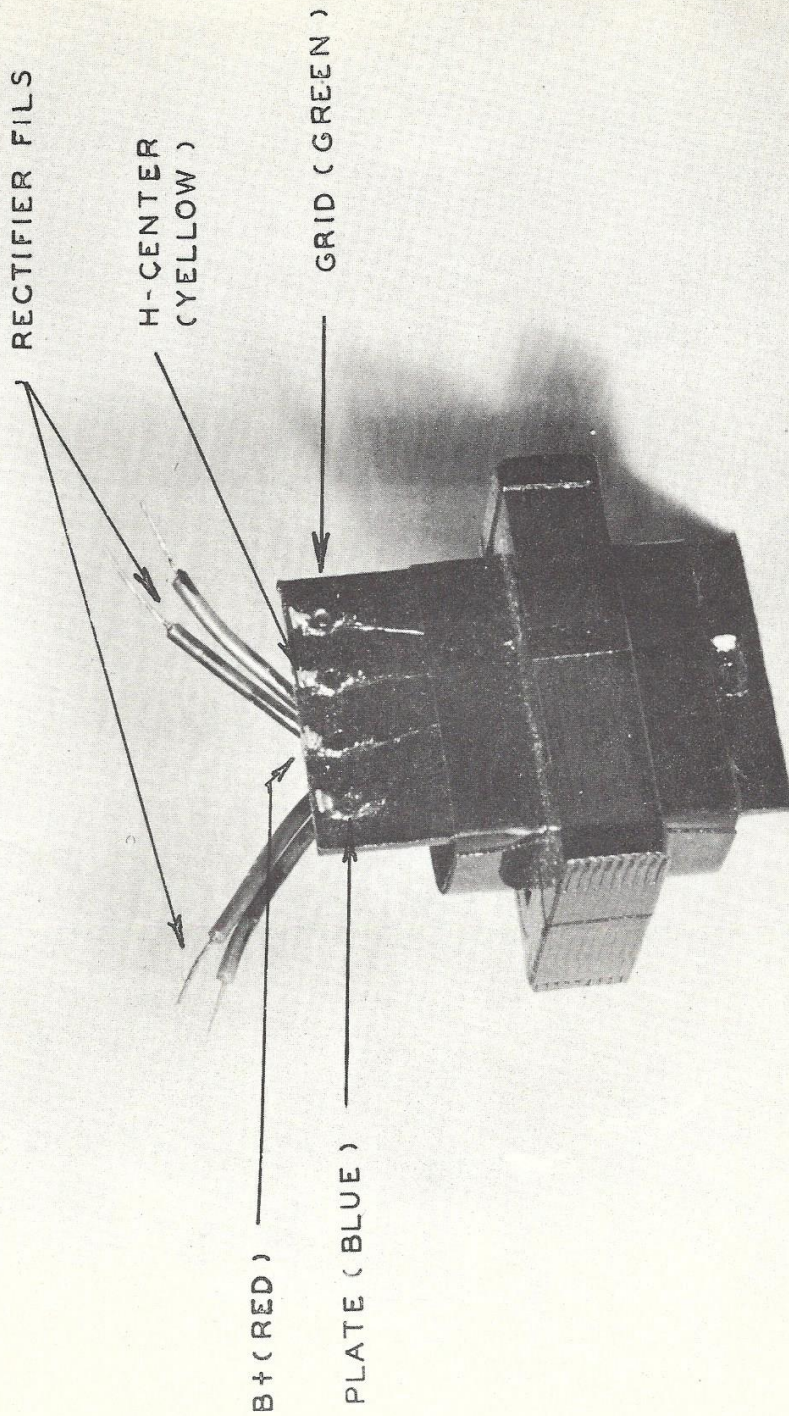

H - DEFLECTION TRANSFORMER
(MONITOR)

FIGURE 17 - B

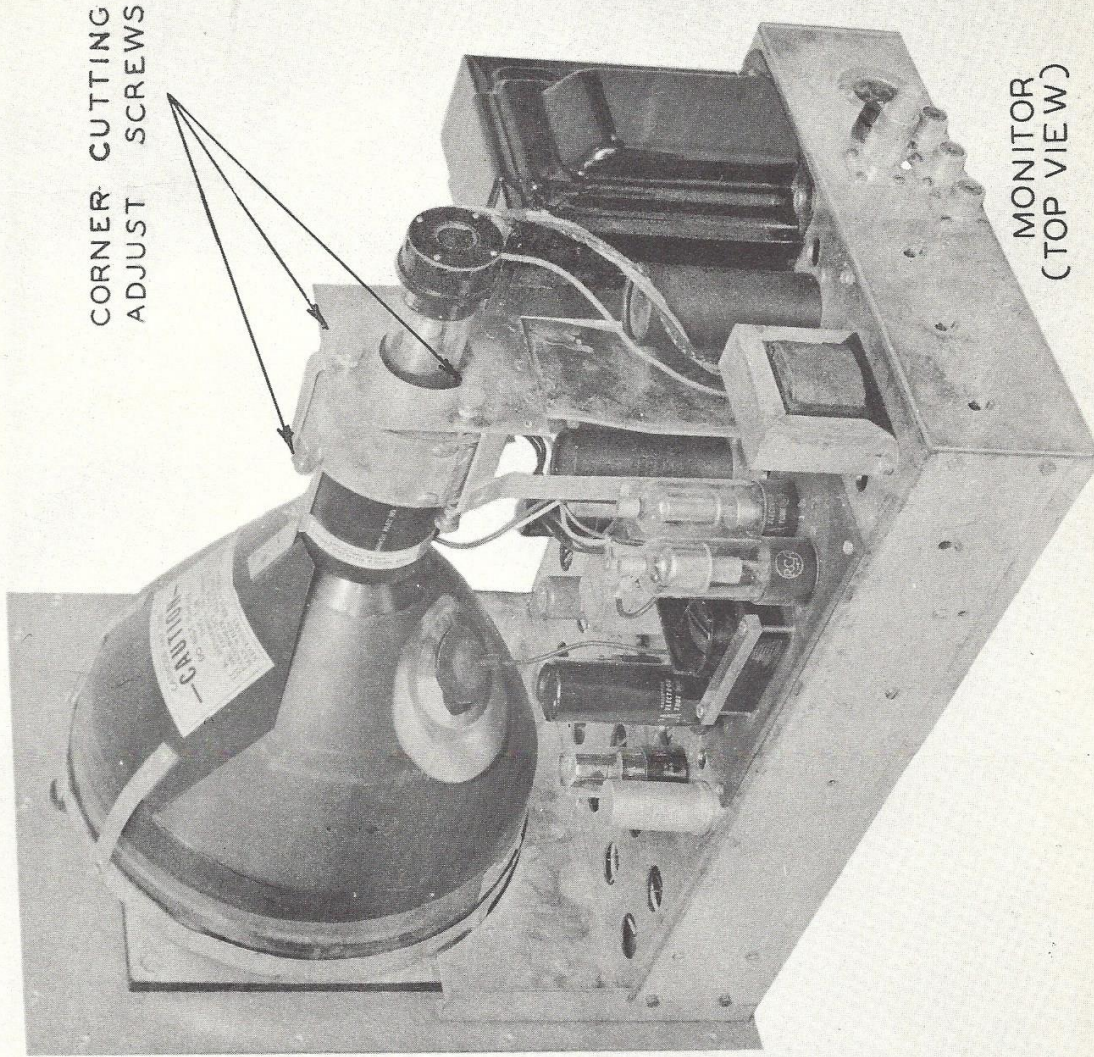

CORNER CUTTING
ADJUST SCREWS

MONITOR
(TOP VIEW)

FIGURE 18

B+(RED TERMINAL)
+ 350 VOLTS

H-V CHECK
+ 7500 V
PIN 2

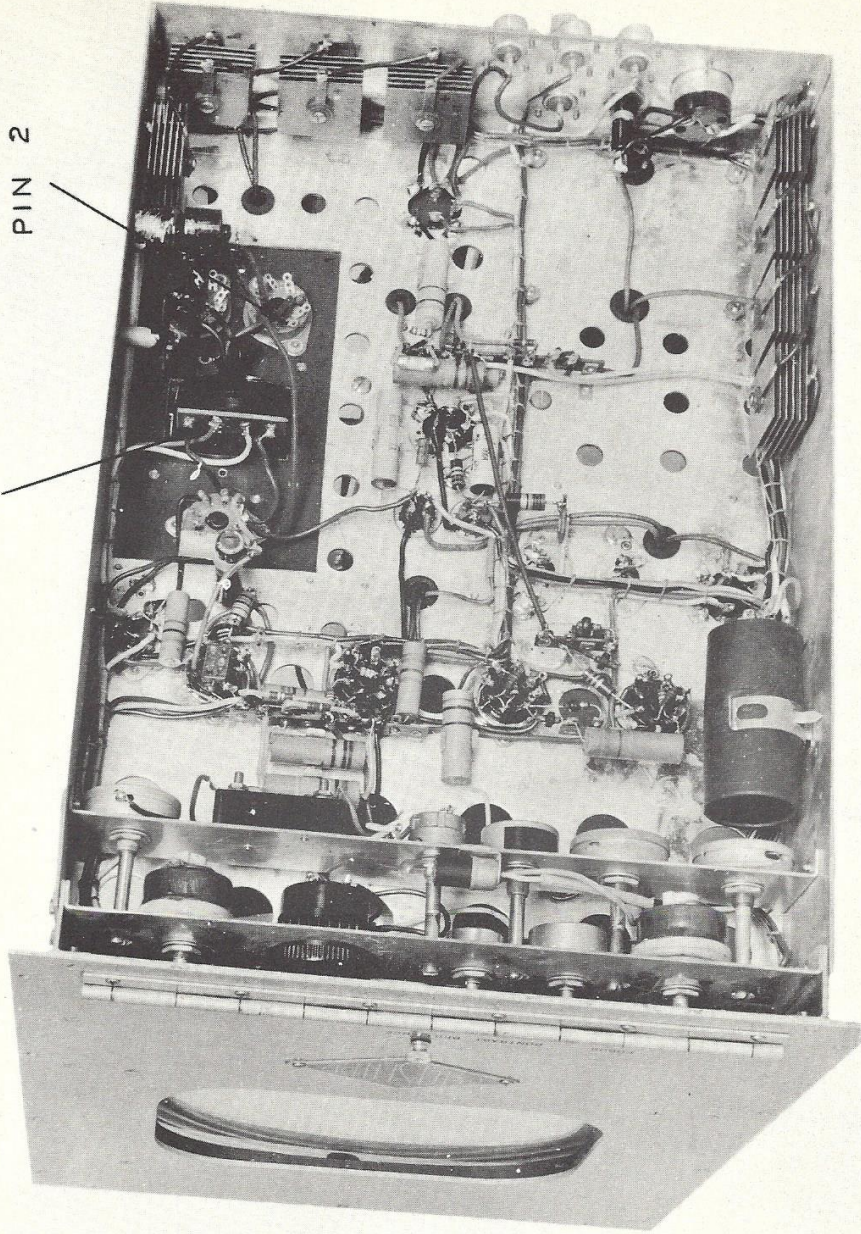

MONITOR
(BOTTOM VIEW)

FIGURE 19

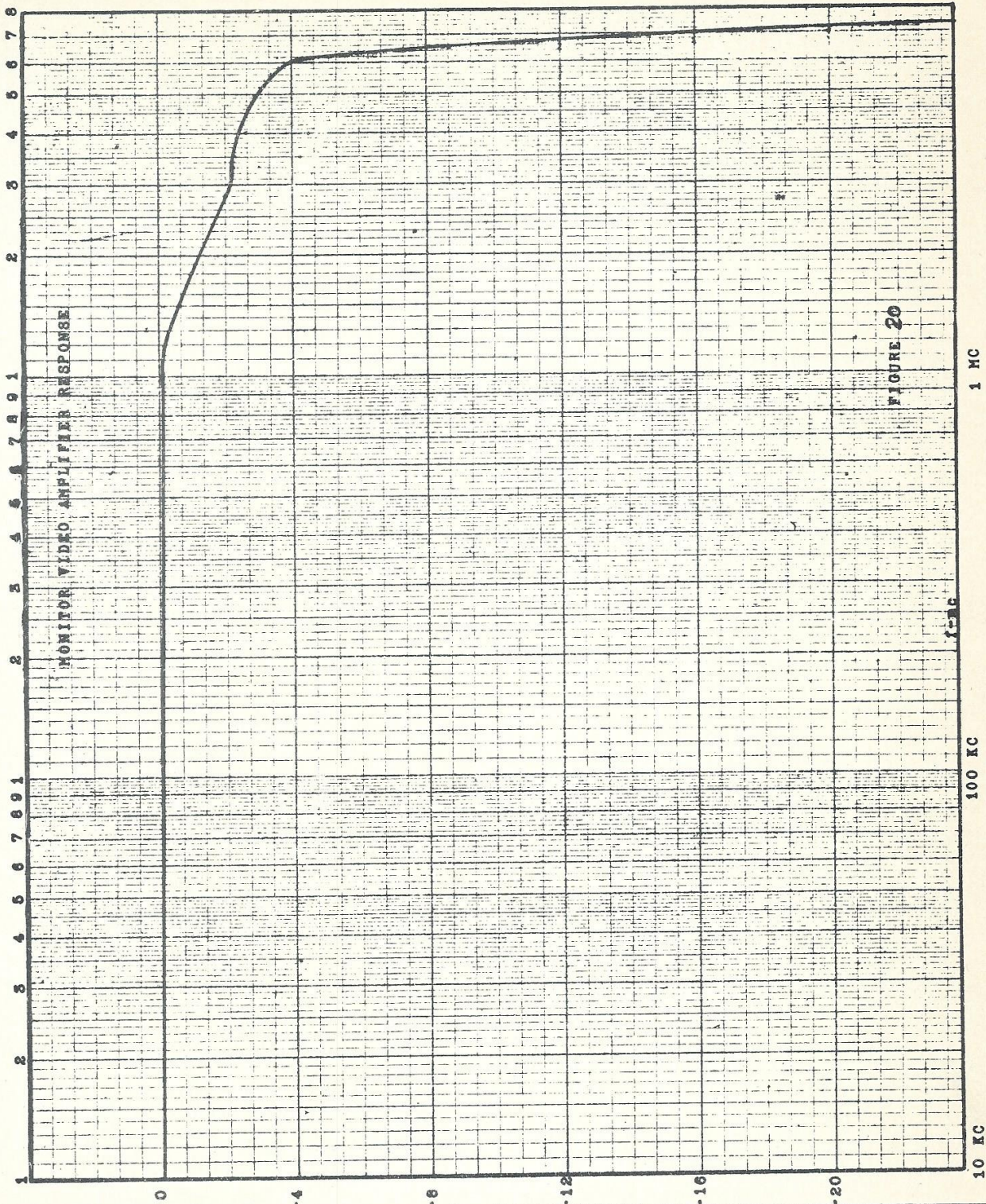
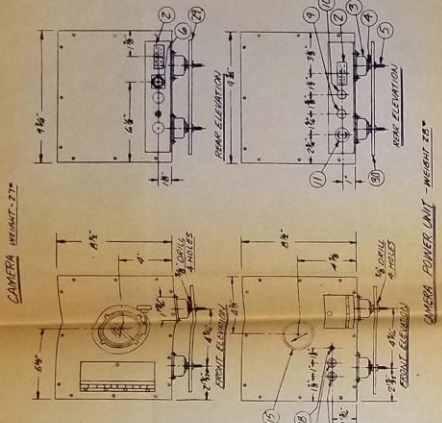

FIGURE 20

| | | | |
|-------------|-------|---|-----------|
| DRAWN BY | DATE | DIAMOND POWER SPECIALTY CORP. LANCASTER, OHIO | DRAW. NO. |
| CHECKED BY | SCALE | | |
| APPROVED BY | | | |

FIG 21

FOR EXPLANATORY PURPOSES ONLY
 REGARDLESS OF MATERIALS AND
 DIMENSIONS OF CASES, AS THESE
 ARE NOT APPLICABLE TO MODEL 3000



NOTE: ALL DIMENSIONS SHOWN ARE IN INCHES

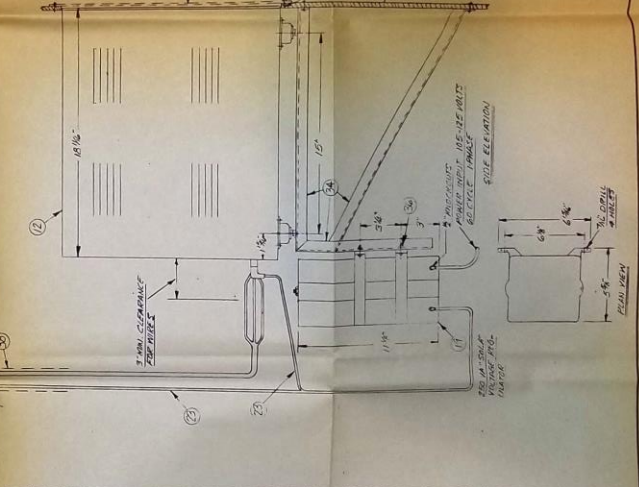
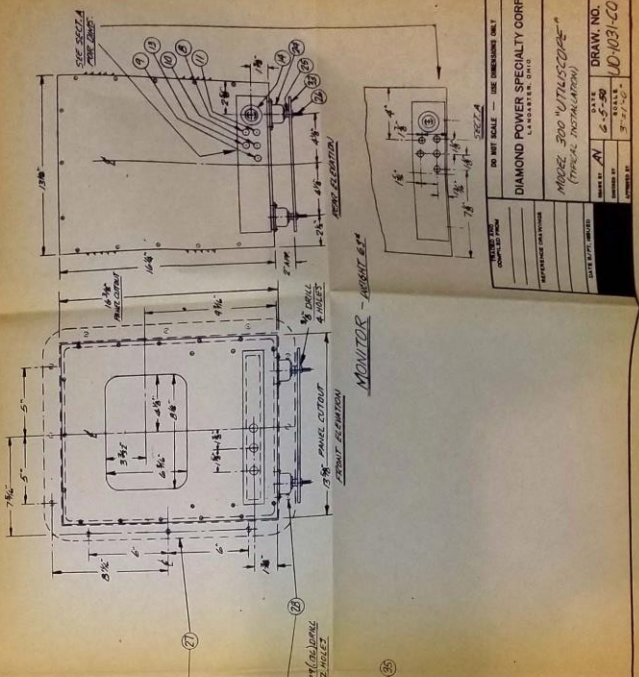
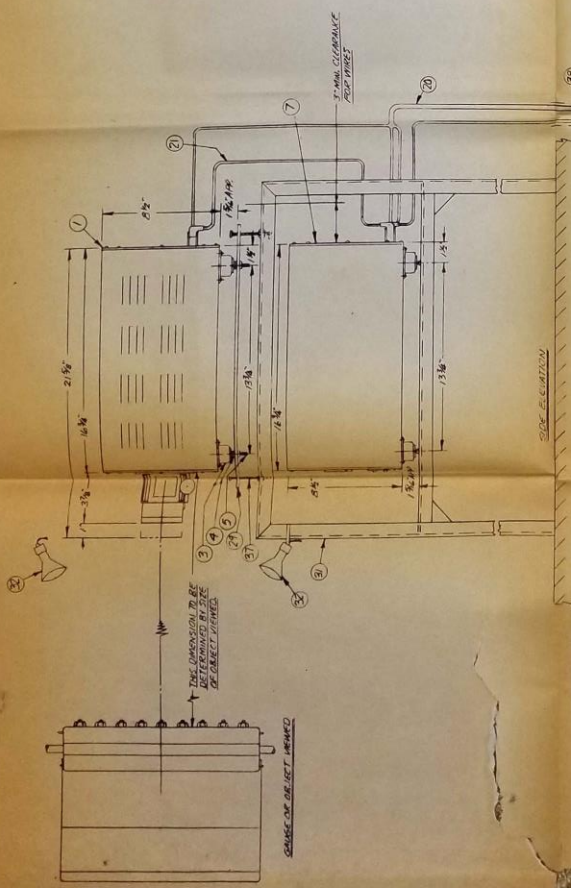

BILL OF MATERIAL - FURNISHED BY D.P.R.C.

| ITEM NO. | DESCRIPTION | QUANTITY | UNIT | REMARKS |
|----------|------------------|----------|-------------|---------|
| 1 | MONITOR ASSEMBLY | 1 | ASST. REQD. | |
| 2 | MONITOR ASSEMBLY | 1 | ASST. REQD. | |
| 3 | MONITOR ASSEMBLY | 1 | ASST. REQD. | |
| 4 | MONITOR ASSEMBLY | 1 | ASST. REQD. | |
| 5 | MONITOR ASSEMBLY | 1 | ASST. REQD. | |
| 6 | MONITOR ASSEMBLY | 1 | ASST. REQD. | |
| 7 | MONITOR ASSEMBLY | 1 | ASST. REQD. | |
| 8 | MONITOR ASSEMBLY | 1 | ASST. REQD. | |
| 9 | MONITOR ASSEMBLY | 1 | ASST. REQD. | |
| 10 | MONITOR ASSEMBLY | 1 | ASST. REQD. | |
| 11 | MONITOR ASSEMBLY | 1 | ASST. REQD. | |
| 12 | MONITOR ASSEMBLY | 1 | ASST. REQD. | |
| 13 | MONITOR ASSEMBLY | 1 | ASST. REQD. | |
| 14 | MONITOR ASSEMBLY | 1 | ASST. REQD. | |
| 15 | MONITOR ASSEMBLY | 1 | ASST. REQD. | |
| 16 | MONITOR ASSEMBLY | 1 | ASST. REQD. | |
| 17 | MONITOR ASSEMBLY | 1 | ASST. REQD. | |
| 18 | MONITOR ASSEMBLY | 1 | ASST. REQD. | |
| 19 | MONITOR ASSEMBLY | 1 | ASST. REQD. | |
| 20 | MONITOR ASSEMBLY | 1 | ASST. REQD. | |
| 21 | MONITOR ASSEMBLY | 1 | ASST. REQD. | |
| 22 | MONITOR ASSEMBLY | 1 | ASST. REQD. | |
| 23 | MONITOR ASSEMBLY | 1 | ASST. REQD. | |
| 24 | MONITOR ASSEMBLY | 1 | ASST. REQD. | |
| 25 | MONITOR ASSEMBLY | 1 | ASST. REQD. | |
| 26 | MONITOR ASSEMBLY | 1 | ASST. REQD. | |
| 27 | MONITOR ASSEMBLY | 1 | ASST. REQD. | |
| 28 | MONITOR ASSEMBLY | 1 | ASST. REQD. | |
| 29 | MONITOR ASSEMBLY | 1 | ASST. REQD. | |
| 30 | MONITOR ASSEMBLY | 1 | ASST. REQD. | |
| 31 | MONITOR ASSEMBLY | 1 | ASST. REQD. | |
| 32 | MONITOR ASSEMBLY | 1 | ASST. REQD. | |
| 33 | MONITOR ASSEMBLY | 1 | ASST. REQD. | |
| 34 | MONITOR ASSEMBLY | 1 | ASST. REQD. | |
| 35 | MONITOR ASSEMBLY | 1 | ASST. REQD. | |
| 36 | MONITOR ASSEMBLY | 1 | ASST. REQD. | |
| 37 | MONITOR ASSEMBLY | 1 | ASST. REQD. | |
| 38 | MONITOR ASSEMBLY | 1 | ASST. REQD. | |
| 39 | MONITOR ASSEMBLY | 1 | ASST. REQD. | |
| 40 | MONITOR ASSEMBLY | 1 | ASST. REQD. | |
| 41 | MONITOR ASSEMBLY | 1 | ASST. REQD. | |
| 42 | MONITOR ASSEMBLY | 1 | ASST. REQD. | |
| 43 | MONITOR ASSEMBLY | 1 | ASST. REQD. | |
| 44 | MONITOR ASSEMBLY | 1 | ASST. REQD. | |
| 45 | MONITOR ASSEMBLY | 1 | ASST. REQD. | |
| 46 | MONITOR ASSEMBLY | 1 | ASST. REQD. | |
| 47 | MONITOR ASSEMBLY | 1 | ASST. REQD. | |
| 48 | MONITOR ASSEMBLY | 1 | ASST. REQD. | |
| 49 | MONITOR ASSEMBLY | 1 | ASST. REQD. | |
| 50 | MONITOR ASSEMBLY | 1 | ASST. REQD. | |
| 51 | MONITOR ASSEMBLY | 1 | ASST. REQD. | |
| 52 | MONITOR ASSEMBLY | 1 | ASST. REQD. | |
| 53 | MONITOR ASSEMBLY | 1 | ASST. REQD. | |
| 54 | MONITOR ASSEMBLY | 1 | ASST. REQD. | |
| 55 | MONITOR ASSEMBLY | 1 | ASST. REQD. | |
| 56 | MONITOR ASSEMBLY | 1 | ASST. REQD. | |
| 57 | MONITOR ASSEMBLY | 1 | ASST. REQD. | |
| 58 | MONITOR ASSEMBLY | 1 | ASST. REQD. | |
| 59 | MONITOR ASSEMBLY | 1 | ASST. REQD. | |
| 60 | MONITOR ASSEMBLY | 1 | ASST. REQD. | |
| 61 | MONITOR ASSEMBLY | 1 | ASST. REQD. | |
| 62 | MONITOR ASSEMBLY | 1 | ASST. REQD. | |
| 63 | MONITOR ASSEMBLY | 1 | ASST. REQD. | |
| 64 | MONITOR ASSEMBLY | 1 | ASST. REQD. | |
| 65 | MONITOR ASSEMBLY | 1 | ASST. REQD. | |
| 66 | MONITOR ASSEMBLY | 1 | ASST. REQD. | |
| 67 | MONITOR ASSEMBLY | 1 | ASST. REQD. | |
| 68 | MONITOR ASSEMBLY | 1 | ASST. REQD. | |
| 69 | MONITOR ASSEMBLY | 1 | ASST. REQD. | |
| 70 | MONITOR ASSEMBLY | 1 | ASST. REQD. | |
| 71 | MONITOR ASSEMBLY | 1 | ASST. REQD. | |
| 72 | MONITOR ASSEMBLY | 1 | ASST. REQD. | |
| 73 | MONITOR ASSEMBLY | 1 | ASST. REQD. | |
| 74 | MONITOR ASSEMBLY | 1 | ASST. REQD. | |
| 75 | MONITOR ASSEMBLY | 1 | ASST. REQD. | |
| 76 | MONITOR ASSEMBLY | 1 | ASST. REQD. | |
| 77 | MONITOR ASSEMBLY | 1 | ASST. REQD. | |
| 78 | MONITOR ASSEMBLY | 1 | ASST. REQD. | |
| 79 | MONITOR ASSEMBLY | 1 | ASST. REQD. | |
| 80 | MONITOR ASSEMBLY | 1 | ASST. REQD. | |
| 81 | MONITOR ASSEMBLY | 1 | ASST. REQD. | |
| 82 | MONITOR ASSEMBLY | 1 | ASST. REQD. | |
| 83 | MONITOR ASSEMBLY | 1 | ASST. REQD. | |
| 84 | MONITOR ASSEMBLY | 1 | ASST. REQD. | |
| 85 | MONITOR ASSEMBLY | 1 | ASST. REQD. | |
| 86 | MONITOR ASSEMBLY | 1 | ASST. REQD. | |
| 87 | MONITOR ASSEMBLY | 1 | ASST. REQD. | |
| 88 | MONITOR ASSEMBLY | 1 | ASST. REQD. | |
| 89 | MONITOR ASSEMBLY | 1 | ASST. REQD. | |
| 90 | MONITOR ASSEMBLY | 1 | ASST. REQD. | |
| 91 | MONITOR ASSEMBLY | 1 | ASST. REQD. | |
| 92 | MONITOR ASSEMBLY | 1 | ASST. REQD. | |
| 93 | MONITOR ASSEMBLY | 1 | ASST. REQD. | |
| 94 | MONITOR ASSEMBLY | 1 | ASST. REQD. | |
| 95 | MONITOR ASSEMBLY | 1 | ASST. REQD. | |
| 96 | MONITOR ASSEMBLY | 1 | ASST. REQD. | |
| 97 | MONITOR ASSEMBLY | 1 | ASST. REQD. | |
| 98 | MONITOR ASSEMBLY | 1 | ASST. REQD. | |
| 99 | MONITOR ASSEMBLY | 1 | ASST. REQD. | |
| 100 | MONITOR ASSEMBLY | 1 | ASST. REQD. | |

DIAMOND POWER SPECIALTY CORP.
 MODEL 3000 UTILISCOPE
 (THERMAL INSULATION)
 DRAW. NO. 101031-20

Cathode Sensitivity 70 $\mu\text{g}/\text{lumen}$
 Light incident on Cathode - 25 ft candles
 or 25 lumens/ ft^2

$$\frac{25}{144} = \text{lumen}/\text{in}^2$$

$$\text{Aperture size } .005' \times .005' = (5 \times 10^{-3})^2 = 25 \times 10^{-6} \text{ in}^2$$

$$\frac{(25)(25) \times 10^{-6}}{144} = \frac{625}{144} \times 10^{-6} \text{ lumens/aperture size}$$

$$\frac{625}{144} \times 10^{-6} \times 70 = \mu\text{g to 1st dynode}$$

$$\text{approx } 3.5 \times 10^{-6} \mu\text{a}$$

$$6 \times 10^{-4} \text{ mampere}$$

$$12 \overline{) .050}$$

$$75 \overline{) 900}$$

$$280 \overline{) 7}$$

$$\frac{900}{2} = 300$$