

# RCC TELEVISION RADIO HI-FI SERVICE MANUAL

1970  
NUMBER  
**119**

PUBLISHED BY RADIO COLLEGE OF CANADA, TORONTO

## INDEX

### CHECK YOUR TUBE INVENTORY

A list of tube types used in TV receivers covered by this supplement appears on page 17.

## ADMIRAL

### COLOR TV

Chassis	Page
H10-7X Circuit .....	45
H10-7X Tuners, coil identification .....	2
H10-8XU Circuit .....	48
H10-8XU Tuners, coil identification .....	3
H10-9X Circuit .....	51
H10-9X Tuners, coil identification .....	4
H10-10X Circuit .....	54
H10-10X Tuners, coil identification .....	5

Other data for all above same as H10-4X, Supp. #94.

### Model

2C211 = H10-7X
2L221 = H10-7X
5C311 = H10-8XU
5C321 = H10-8XU
5C381 = H10-7X
5L331 = H10-8XU
5L391 = H10-7X
5ST311 = H10-7X & 20E5X Radio
19CT27 = H10-7X
19CTA13 = H10-10X
19CTR13 = H10-9X & 4C4X Radio
19CTR27 = H10-9X & 4C4X Radio

### RADIO

4C4X All data .....	6
20E5X, AX All data .....	43

## CGE

### COLOR TV

Chassis	Page
M718 Circuit .....	65
M718 Alignment .....	7 to 11
M718 Layouts .....	12, 13
M718 Waveforms .....	14
M718 Coil identification .....	11

### Model

C1911R = M718
C1952R = M718

We reproduce C. G. E. service data that is essential to most service technicians. If further information is required, it may be obtained at a nominal charge from: Canadian General Electric Co., 830 Lansdowne Ave., Toronto, Ont.

## DUMONT

### B & W TV

Model	Page
DP33, UHF Circuit .....	57
DP33, UHF Tuner circuits .....	18
DP36 All data .....	59
DP37 All data .....	59
DP38 All data .....	59

## ELECTROHOME

### B & W TV

Chassis	Page
M8 Circuit .....	63
M8 Tuner data .....	17
M8 Alignment .....	15, 16
M8 Coil identification .....	16

### Model

Safari M08-102 = M8
Sprite M08-101 = M8

## EMERSON

### B & W TV

Model	Page
E184 A, B, C etc. Circuit .....	19
E184 A, B, C etc. Audio section .....	20
E185 A, B, C etc. = E184.	
E196 A, B, C etc. = E184.	

## FLEETWOOD

### B & W TV

Model	Page
19-55 All data .....	61

## MAGNAVOX

### RADIO

Chassis	Page
R223-03-DC & 72 All data .....	40

## PHILCO

### RADIO

Chassis	Page
T150ST All data .....	75
T150STA All data .....	77
T300ST All data .....	79

## RCA

### COLOR TV

Chassis	Page
CTC39AB Circuit .....	68
CTC39AB Tuner data .....	28 to 36
CTC39AB Remote amplifiers .....	37, 39
CTC39AB Remote transmitter .....	38, 97
CTC39AB Alignment .....	21 to 27
CTC39AB Layouts .....	98
CTC39AB Printed boards & waveforms .....	99 to 103
CTC39AB Coil identification .....	38
CTC39XA = CTC39AB.	
CTC39XZ, XZR = CTC39AB.	

## Model Chassis Pic. tube

CCB620W	CTC39AB	22JP22
CCB621W	CTC39AB	22JP22
CCB622W, Z	CTC39XA	22JP22
CCB841W	CTC39XA	25BG22
CCB841WR	CTC39XB	25BG22
CCB842W	CTC39XA	25BG22
CCB843W	CTC39XA	25BG22
CCB844W	CTC39XA	25BG22
CCB904W	CTC39XZ	25VABP22
CCB905W, X	CTC39XZ	25VABP22
CCB905XR	CTC39XZR	25VABP22
CCB906W	CTC39XZ	25VABP22
CCB906WR	CTC39XZR	25VABP22
CCB907L	CTC39XZ	25VABP22
CCB907LR	CTC39XZR	25VABP22
CCB908H	CTC39XZ	25VABP22
CCB909Q, S	CTC39XZ	25VABP22
CCB909QR	CTC39XZR	25VABP22
CCB909SR	CTC39XZR	25VABP22
CCB910F, X	CTC39XZ	25VABP22
CCB910FR	CTC39XZR	25VABP22
CCB910XR	CTC39XZR	25VABP22
CCB911Q	CTC39XZ	25VABP22
CCB911QR	CTC39XZR	25VABP22
CCB920W	CTC39XZ	25VABP22

### RADIO

Model	Page
RZC270 All data .....	71
RZM198, E All data .....	73

## SIMPSONS-SEARS

### RADIO

Chassis	Page
562, 90506 All data .....	81 to 84
C817, 50090 All data .....	85
C817, 50100 All data .....	87
C817, 50110 All data .....	87
C817, 50120 All data .....	87
C840, 30030 All data .....	89

## SONY

### COLOR TV

Model	Page
KV-1210U (SCC-06-A, B, C) Circuit .....	91
KV-1210U (SCC-06-D) Circuit .....	94
KV-1210U (A to D) Waveforms .....	104, 105
KV-1210U (A to D) Block diagram .....	107
KV-1210U (SCC-06-C) Printed board .....	108
KV-1210U (A to D) Coil identification .....	105, 106

Note: The version of the KV-1210U that appeared in Supp. #116 was for serial numbers up to 11000.

## ZENITH

### B & W TV

Chassis	Page
14B35 All data .....	109, 110
14B36 All data .....	111, 112

SCTV

HORIZONTAL DEFLECTION ADJUSTMENTS AND HIGH VOLTAGE CHECK

**STEP 1**  
**SINE WAVE COIL (L215B)**

- Tune receiver to an active channel and adjust contrast and brightness for normal picture.
- Disable sync by shorting C254 to ground at junction of C254 and C255.
- Short the sine wave coil L215B to ground by connecting a shorting jumper between pin 8 of V204 and ground.
- Adjust the horizontal hold control, R131, so that the horizontal is on frequency (picture sides vertical).
- Remove short from sine wave coil, (L215B) and adjust L215B so that picture sides are again vertical or drifting slowly horizontally.
- Remove jumper from C254 to ground.

NOTE: Picture should lose sync at both ends of rotative horizontal hold control. If not remove R102.

SECTIONS OF PW200 BOARD  
VIEWED FROM  
COPPER SIDE

**STEP 2**  
**HORIZONTAL EFFICIENCY COIL (L706)**

- Disconnect the cathode jumper from pin 3 of the 6L06 horizontal output tube.
- Connect a 0-500mA meter between pin 3 of the 6L06 and ground. Shunt the meter with a .47 UF capacitor.
- Adjust L706 for minimum cathode current. Then, while monitoring the regulator current as outlined in step 3, advance the core into the coil to increase the cathode current by 1 or 2 mA. Do not exceed 235mA. The core should be on the bottom or board end of coil.

SECTION OF PW700 BOARD  
VIEWED FROM  
COPPER SIDE

**STEP 3**  
**REGULATOR CURRENT**

- Connect a VOM across R120 which is in series with pin 1, the cathode of the 6BK4 regulator tube. Use the 2.5v scale on the meter.
- When increasing the 6L06 cathode current in step 2, the regulator current must also increase as shown by an increase in the voltage drop across R120, if the regulator current decreases, the core was turned the wrong direction from the dip.
- Turn brightness and contrast controls to minimum (maximum CCW) and observe the regulator current. With black picture, (high voltage set at 25kv) the voltage drop across R120 must be at least 0.96v (960 ua. regulator current).

**STEP 4**  
**BRIGHTNESS LIMITER ADJUSTMENT AND HIGH VOLTAGE CHECK**

- Connect a VTVM using a high voltage probe to the second anode lead of the picture tube. The VTVM should be set on the 500 volt scale.
- Set the brightness control fully clockwise. Set the contrast control for mid-range. Note reading on VTVM. Adjust the brightness limiter so that the high voltage dips .5KV to 1KV.
- Set the brightness control to minimum. Connect a 220K ohm resistor from the grid of the shunt regulator 6BK4B tube (pin 5) to ground. The measured high voltage should be less than 28KV with black screen.

NOTE: This check verifies proper action of the shunt regulator "fail-safe" circuit, thus assuring full protection from X-Ray radiation.

- Remove the resistor from pin 5 of the shunt regulator tube. Return brightness control to normal position and remove VTVM.

HIGH VOLTAGE PROBE 100-1





CTC39 SOUND I F 4.5 MHz TRAP ALIGNMENT

**STEP 1: 4.5MHz TRAP ALIGNMENT**

Apply—67.5 volts to PW200-D. Set Service Switch to SERVICE position. Disconnect horizontal output tube cathode jumper. Disable AFT. Connect signal generator through .001 UF to PW200-TP2. Set generator to 4.5MHz/600Hz modulation. Connect Oscilloscope through video detector shown (8B105 Probe) to V701-6. Adjust core of L212 for minimum 600Hz output on scope (choose the null obtained with the core located nearest mounting end of coil form).

**STEP 2: Disconnect Marker Generator.**

Move detector probe, 8B105, to PW200-TP4 and connect output of probe to VTVM. Set service switch to NORMAL position and tune in strong local channel.

Disconnect bias at PW200-D. Attenuate signal with fine tuning (or remove antenna) to maintain 0.2 volts output from detector. Adjust T201 for maximum D.C. (choose the peak obtained with the core located nearest top of coil form).

Adjust bottom core of T2Q2 for minimum D.C. (choose the null obtained with the core located nearest mounting end of coil form).

**STEP 3:** Remove all test equipment. Reduce signal level with fine tuning until hiss is heard in sound. Adjust quadrature coil, T203, for maximum volume. Adjust top core of T2Q2 for clearest sound.

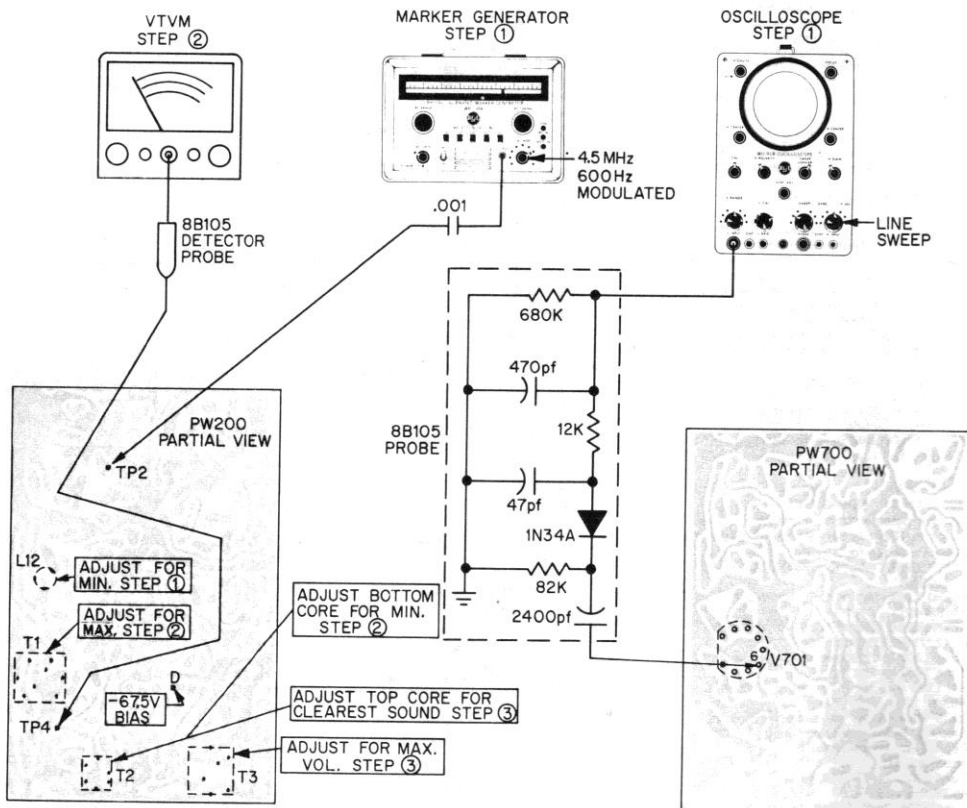

CTC39X AFT ALIGNMENT

If circuit is completely misaligned, connect equipment as for IF Sweep Alignment and adjust input for Specified PP Voltage at 2nd Detector T.P.

Bias IF the same as in the IF Alignment.

Disconnect lead at "A" and connect Scope using Direct Probe.

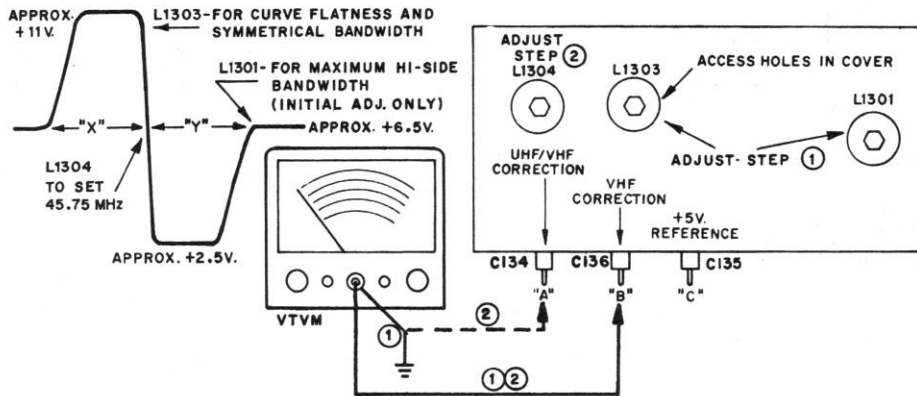

L1303 is adjusted for maximum output (top and bottom curve flatness) and symmetrical width (X approximately = Y) when L1304 is adjusted for a 45.75 MHz crossover point. Then L1301 is adjusted for maximum bandwidth on the high frequency side starting with the core initially set toward the top of the coil form. The curve at "B" should be the same as the curve at "A"—but INVERTED.

Remove the sweep and apply a 46.1 MHz CW signal in its place.

Set the input signal strength so that the reading at "B" falls between 7.5 and 9.0 V, as measured with a VTVM.

STEP 1

Alternate between L1301 and L1303 and adjust for a maximum output peak, using additional input attenuation to keep the peak between 7.5 and 9.0 V, as the proper core settings are reached. (Watching a dip on "A" gives exactly the same alignment as watching the peak on "B".)

Remove the 46.1 MHz CW signal and apply a 45.75 MHz CW signal of sufficient strength to give a pix detector test point voltage of 1.25 V., which is 1/2 the PP value of the normal IF sweep alignment waveform which occurs at this point (TP201).

STEP 2

Adjust L1304 for zero difference ( $\pm 0.5V$ ) between "A" and "B". This adjustment is somewhat critical but extremely important.

Over a 10.5 to 12.2V. B+ voltage range, the "A" and "B" D.C. outputs (no input signal) are between approximately +6.2 and +7.2 V.D.C.

AFT check

With the AFT completely connected but disabled and after the discriminator secondary (L1304) adjustment has been touched up, bias the IF as for normal IF alignment and feed a channel 2 RF CW signal into the tuner input. Set tuner to channel 2. Then fine tune the receiver for zero difference between C134 and C136. This should yield a 45.75 MHz beat when the IF is sampled with a crystal calibrator (this is only a check).

Adjust the applied signal strength for an output of +1.25 V. D.C. at TP201. Fine tune the receiver 750 kHz high (IF frequency) so that pix carrier is placed at 46.50 MHz. Turn the AFT on. The system should pull the pix carrier back very closely (less than 50 kHz high) to 45.75 MHz with the correction voltage on C134 being no less than +3.5 V. Turn the AFT off.

Fine tune the receiver 1.0 MHz low (IF frequency) in order to yield at 44.75 MHz pix IF frequency. Turn the AFT on and the system should return the pix carrier back very closely (less than 50 kHz low) to 45.75 MHz with the correction voltage on C134 being no more than 9.5 V. Turn AFT off.

Fine tune 2.25 MHz low in order to yield a 43.50 MHz pix IF frequency. Turn AFT on and the system should not return the pix carrier back to 45.75 MHz.

It can be verified that the AFT has pulled the mis-fine-tuned carrier back to near 45.75 MHz (IF frequency) by noting if the pix detector voltage at TP201 has returned very closely back to its initial 45.75 MHz output of +1.25 V. D.C.



CTC 39 CHROMA BANDPASS ALIGNMENT

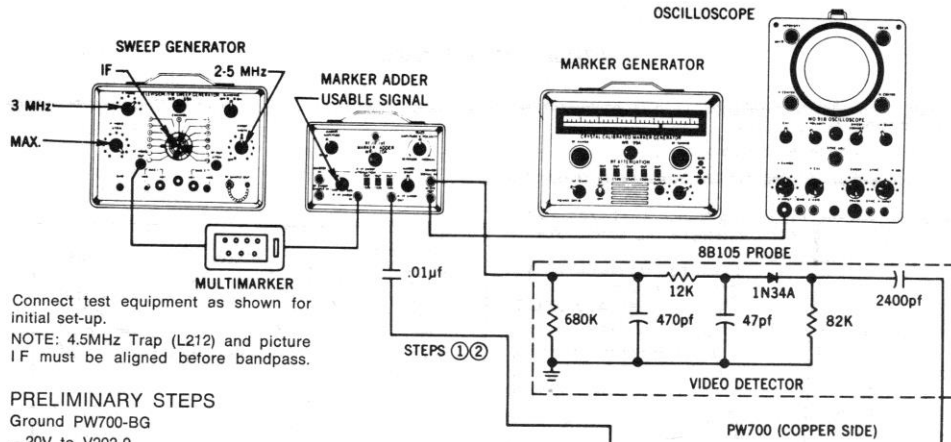

Connect test equipment as shown for initial set-up.  
NOTE: 4.5MHz Trap (L212) and picture IF must be aligned before bandpass.

PRELIMINARY STEPS

Ground PW700-BG  
—20V to V202-9  
—67V to PW200-D

STEP ①

Video Sweep to first Bandpass Grid (V701-2) and scope at PW700-W with Video detector probe.

Adjust T701 primary and secondary for response having equal amplitude peaks and equal markers at 3.08MHz and 4.08MHz. When near alignment, adjust bottom core (primary) for equal amplitude peaks and top core (secondary) for marker position.

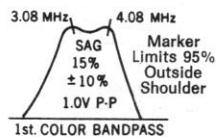

STEP ②

Move detector and scope to TP2.

Leave sweep at V701-2. Attenuate sweep for 2.5V P-P on scope.

Adjust T705 for response shown, core on bottom peak and markers equal.



STEP ③

Leave sweep and detector on TP2. Remove ground at PW700-BG and apply -2.5V Bias.

Set contrast and brightness controls maximum CW. Connect test equipment as shown below and attenuate signal to produce +2V DC on VTVM at TP201.

Adjust peaker coil L701 for a symmetrical waveform about the 3.58MHz Marker. There should be no peak between the 3.58MHz and 4.08MHz Marker.

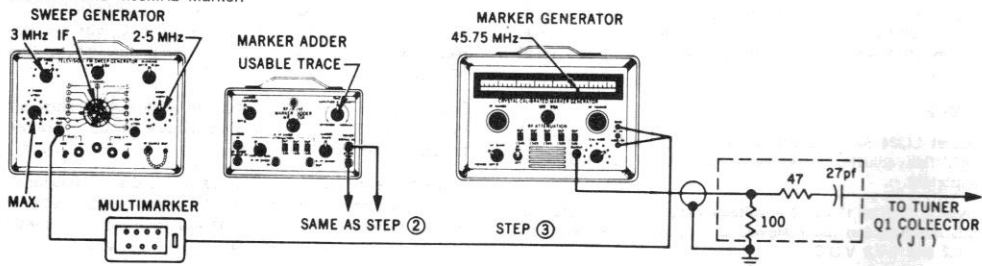
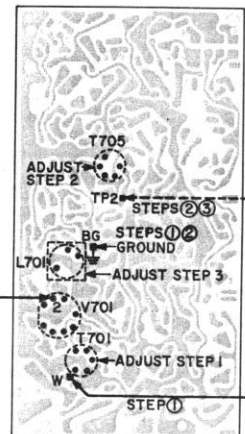
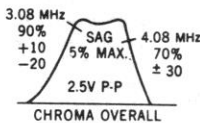

CTC39 AFPC ALIGNMENT

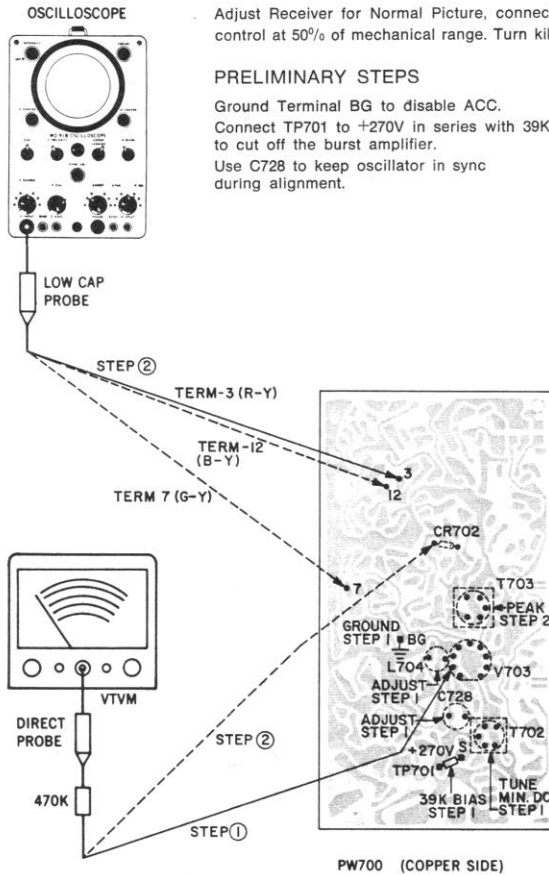

Adjust Receiver for Normal Picture, connect color bar Generator to antenna terminals. Center tint control at 50% of mechanical range. Turn killer control full CCW. AFT off. ATC off. (CCW pos.)

PRELIMINARY STEPS

Ground Terminal BG to disable ACC.  
Connect TP701 to +270V in series with 39K to cut off the burst amplifier.  
Use C728 to keep oscillator in sync during alignment.

STEP ①

Connect VTVM in series with 470K to V703-2.  
Adjust C728 for zero beat.  
Tune T702 for minimum DC voltage. Core on top peak.  
Readjust C728 for zero beat.  
Adjust L704 for exactly -3.5V DC. Use peak with core at mounting end of coil.  
Readjust C728 for zero beat.  
Remove short at BG and bias at TP701.

STEP ②

Set brightness control CCW.  
Move VTVM to CR702 anode.  
Peak T703 for maximum DC and symmetrical drop off at both extremes of the tint control.  
Use peak with core at mounting end of coil.  
Voltages should be equal when tint control is either fully CW or fully CCW.  
Remove VTVM and readjust for zero beat if necessary.  
Connect oscilloscope to PW700-3 (R-Y output) and check for centering of the tint control.  
Also check with scope PW700-12 (B-Y output), PW700-7 (G-Y output) for proper matrixing.  
With R-Y as 100% reference, G-Y should be 30% ± 6% and B-Y should be 120% ± 20%. Check that B-Y phase nulls at 3 1/2 and 9 1/2 bars ± 1/2 bar. Set ATC switch on (CW position). B-Y bar cancellation should increase approximately 1/2 bar (4th and 10th bar cancellation).  
Set killer to just kill on blank noisy channel with color control fully CW and Tint control fully CCW. Check setting on a channel with color.

6th BAR NULLED AT TINT CONTROL MIDRANGE

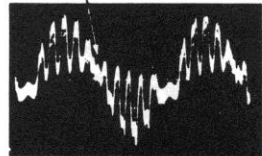

PW700-3 R-Y

NULLED AT 3 1/2 AND 9 1/2 BARS

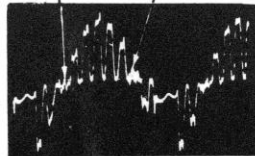

PW700-12 B-Y

NULLED AT 1 1/2 AND 7 1/2 BARS

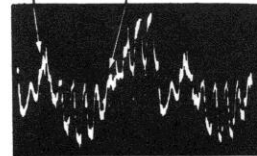

PW700-7 G-Y



KRK173, KRK174 TUNER R F ALIGNMENT

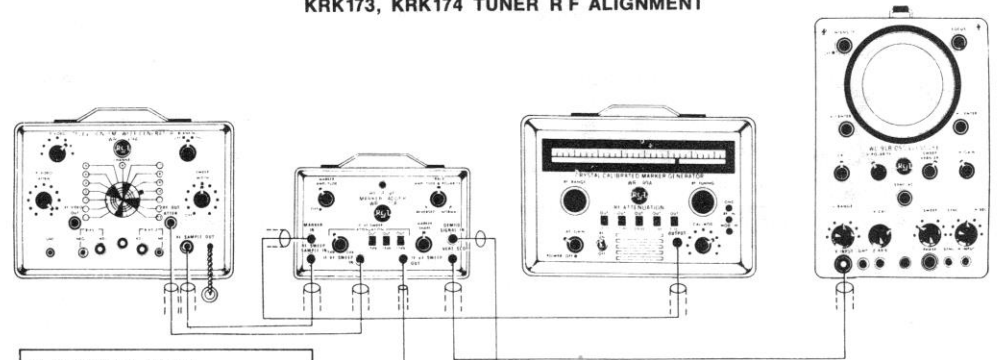

\* RESISTOR VALUE

GENERATOR IMPEDANCE	R1	R2	R3
50 Ω	10	47	56
75 Ω	27	27	100
100 Ω	56	10	120

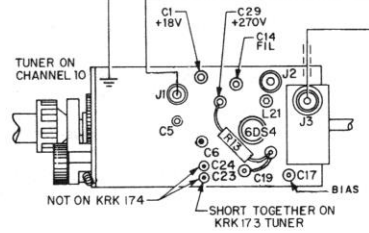
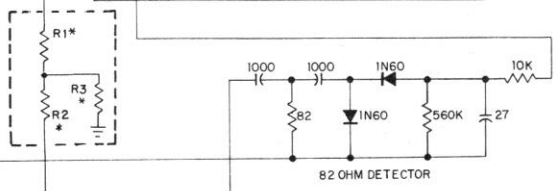

INITIAL CONNECTION:  
 Scope to J1 via 82 ohm detector.  
 Variable bias to C17.  
 Channel 10 sweep to J3 via T pad.  
 Calibrate Scope for .3V P-P.  
 Tuner on Channel 10.  
 Markers at (see frequency chart page 9).

STEP 1

Adjust L5, L10 and L13 for centering on Channel 10 pix and sound markers at equal height and 80% to 100% on curve. Adjust L9 for best coupling with L8 centered between switches; readjust L5 and L10 for flat top curve (see response curves below).

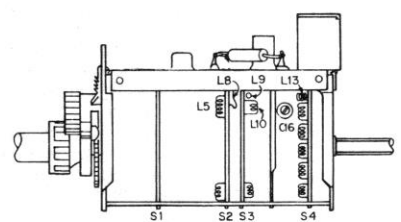

STEP 2

Bias tuner to cut-off, -22 volts to C17.  
 Adjust C16 for minimum response between markers.

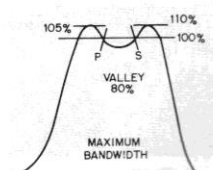
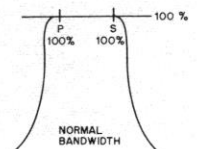
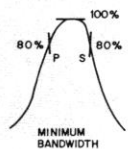

UHF and VHF IF Response Curves

**KRK173, KRK174 TUNER R F ALIGNMENT**

**STEP 3 OSCILLATOR ADJUSTMENT**

—2 Volts at C17, zero bias between C23 and C24 (KRK 173).  
Tuner and sweep on Channel 13. Turn fine tuning maximum clockwise. Using zero beat method, adjust L3 to set local oscillator at (261.5 MHz) 4.5 MHz above nominal frequency (257 MHz). Return fine tuning to nominal frequency (257 MHz) on Channel 13.

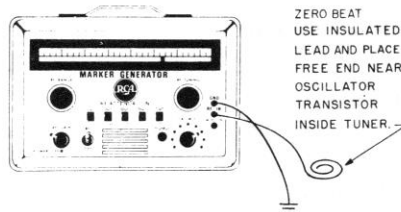

**STEP 4**

Tuner and Sweep on Channel 10.  
Adjust L5, L10 and L13 for centering on Channel 10. Adjust L8 if necessary for correct coupling. Rotate tuner Channels 13 thru 7. Retouch L5, L8, L10 and L13 for best compromise on tracking and coupling on high channels.

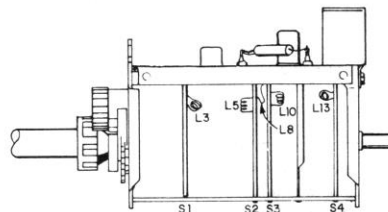

**STEP 5**

Tuner and Sweep on Channel 6.  
Adjust L20 for maximum output, L7 and L12 for proper response curve.  
Rotate tuner and sweep Channels 5 thru 2 in descending order and adjust coils L18 thru L15 for flat topped curve on each channel.

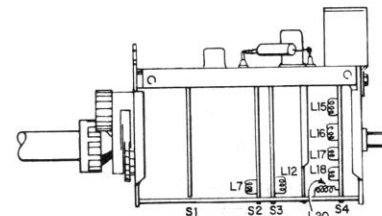

**STEP 6**

Tuner in UHF Position.  
Apply IF sweep to J2 via IF input head.  
Adjust L21 for flat topped curve.

**STEP 7 A F T CHECK**

Apply  $\pm 8$  volts between C23 and C24, oscillator frequency must be shifted  $\pm 1$  MHz or more.

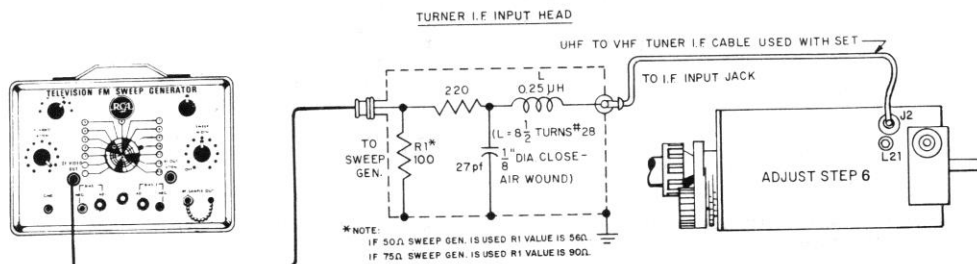

KRK132, KRK138 TUNER R F ALIGNMENT

GENERAL INFORMATION

Remove tuner and detent assembly. Apply 5 volts to C18 A F T (KRK 132).

AFT CHECK (KRK 132).

Apply 1-10 volts to C18. Marker should move a minimum of 3 MHz. Replace CR2 if not within limits.

TEST EQUIPMENT CONNECTIONS:

OSCILLOSCOPE.....Connect, through preamplifier, to output of UHF Alignment fixture. (Figure 2) Calibrate scope .2V P-P.

UHF SWEEP GENERATOR..... Connect to antenna terminals using 300 ohm pad supplied with generator. Set for maximum sweep width.

VHF SIGNAL GENERATOR.....Connect to RF (anode side) of crystal CR1 when aligning the oscillator, and to IF input on UHF alignment fixture during RF sweep alignment. (The former to be used only when the UHF generator does not have internal markers.)

MISCELLANEOUS .....(a) At any alignment point the best alignment (i.e., the lowest noise figure and the highest gain) will occur when the RF response curve is as narrow as possible. (b) Leave the oscil-lator inner shield in place during alignment.

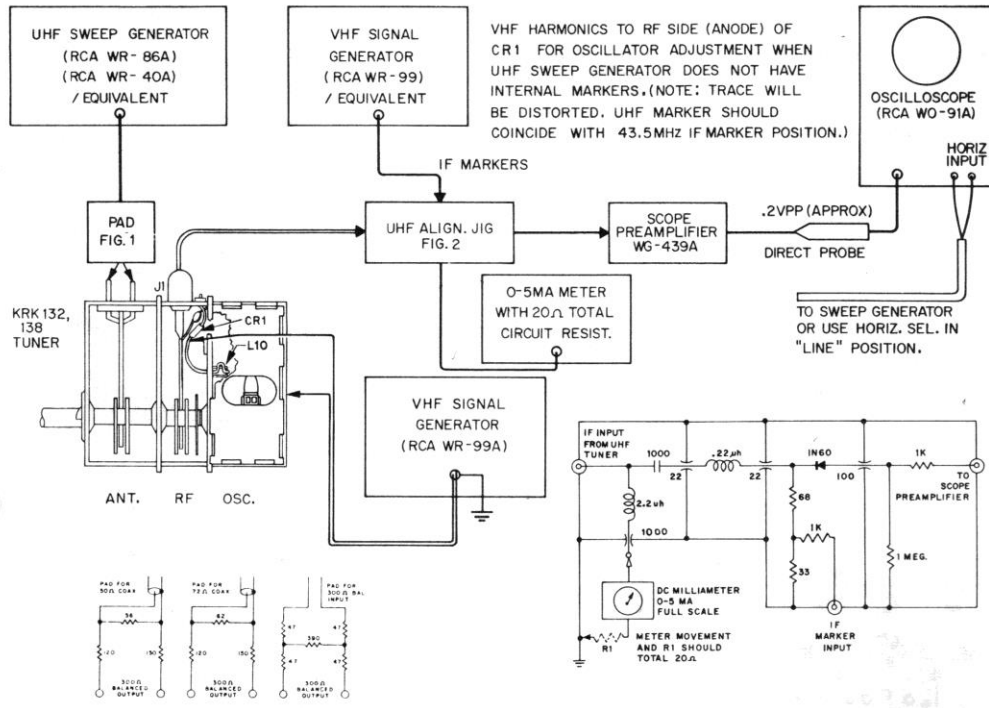

Figure 1 — Sweep Attenuator Pads. (Part of Sweep Gen. Cable)

Figure 2 — UHF Alignment Fixture Schematic

**KRK132, KRK138 TUNER R F ALIGNMENT**

**OSCILLATOR INJECTION CURRENT ADJUSTMENT**

Tune entire range and observe crystal injection level on UHF alignment fixture milliammeter. The oscillator injection current should be between 0.75 and 2.5 mA, and is adjusted by orienting the injection loop L10, in the oscillator compartment, toward the transistor to increase injection, or away from the transistor to decrease injection. If satisfactory results cannot be obtained, change CR1. These injection limits can best be realized with R F alignment and oscillator frequency approximately correct.

**OSCILLATOR ADJUSTMENT**

Sweep and marker at 887 MHz, tuning capacitor on Channel 83. Adjust oscillator rotor segment 1 to set 887 MHz marker to coincide with 43.5 MHz I F marker.

Rotate tuning capacitor to 833 MHz on Channel 74, adjust oscillator segment 2, 761 MHz on Channel 62, adjust oscillator segment 3, 707 MHz on Channel 53, adjust oscillator segment 4, 653 MHz on Channel 44, adjust oscillator segment 5, 581 MHz on Channel 32, adjust oscillator segment 6, 527 MHz on Channel 23, adjust oscillator segment 7, 473 MHz on Channel 14, adjust oscillator segment 8 to set marker to coincide with 43.5 MHz I F marker.

**ANTENNA AND R F ADJUSTMENT**

Remove UHF marker. Sweep and tuning capacitor to Channel 83, adjust segment 1, 833 MHz on Channel 74, adjust segment 2, 761 MHz on Channel 62, adjust segment 3, 707 MHz on Channel 53, adjust segment 4, 653 MHz on Channel 44, adjust segment 5, 581 MHz on Channel 32, adjust segment 6, 527 MHz on Channel 23, adjust segment 7, 473 MHz on Channel 14, adjust segment 8 (on R F and antenna rotor C2 and C4) to place sound marker (41.25 MHz) and pix marker (45.75 MHz) at peak of response curve.

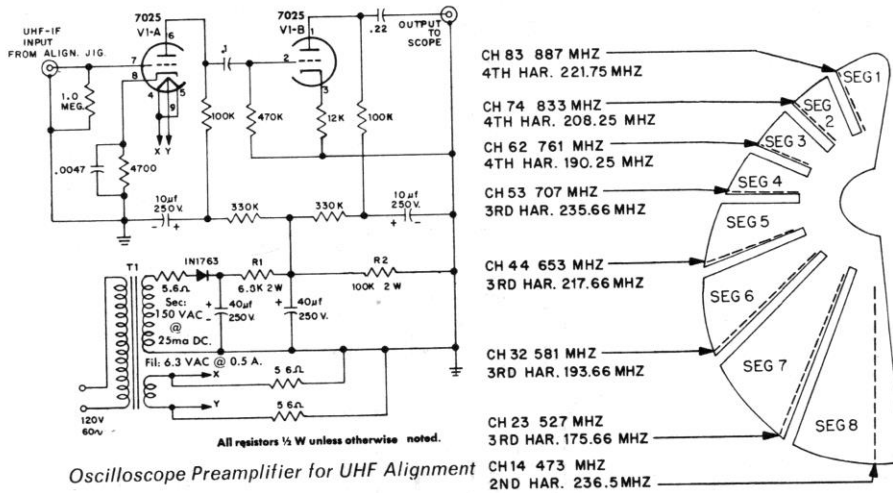

Oscilloscope Pre-amplifier for UHF Alignment

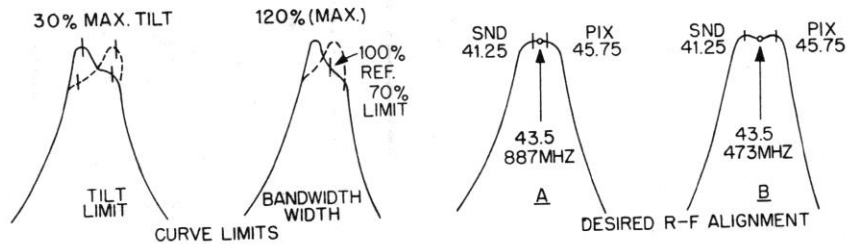

KRK 173/132 VHF/UHF TUNER SCHEMATIC DIAGRAM

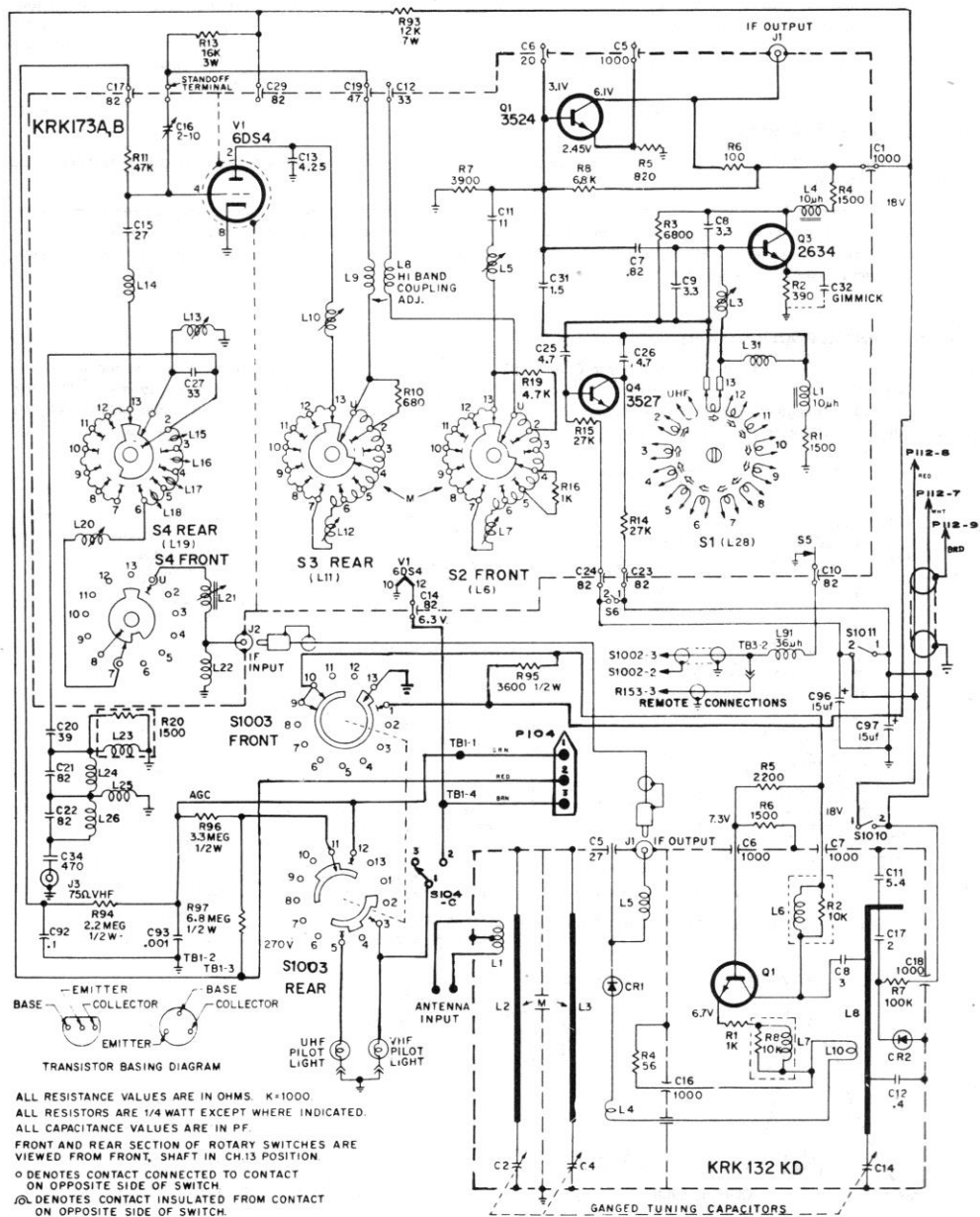

KRK132 ALTERNATE UHF TUNER SCHEMATICS

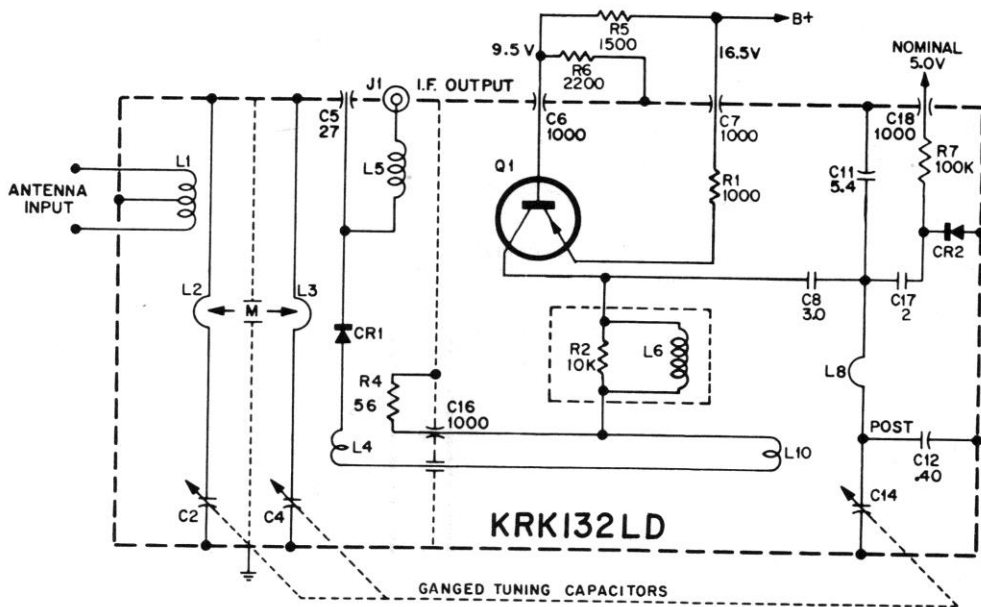
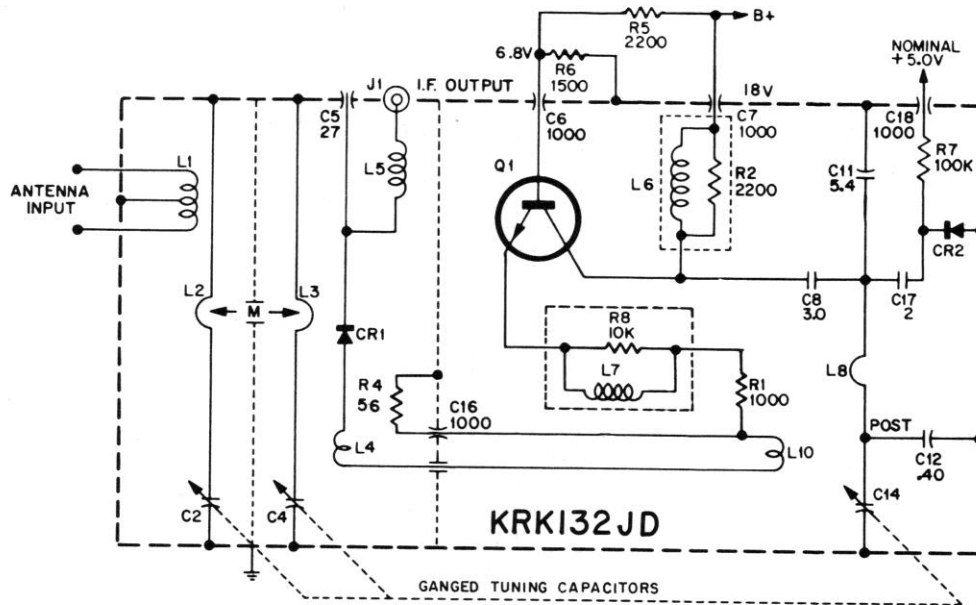



KRK 174A/138KA VHF/UHF TUNER SCHEMATIC DIAGRAM

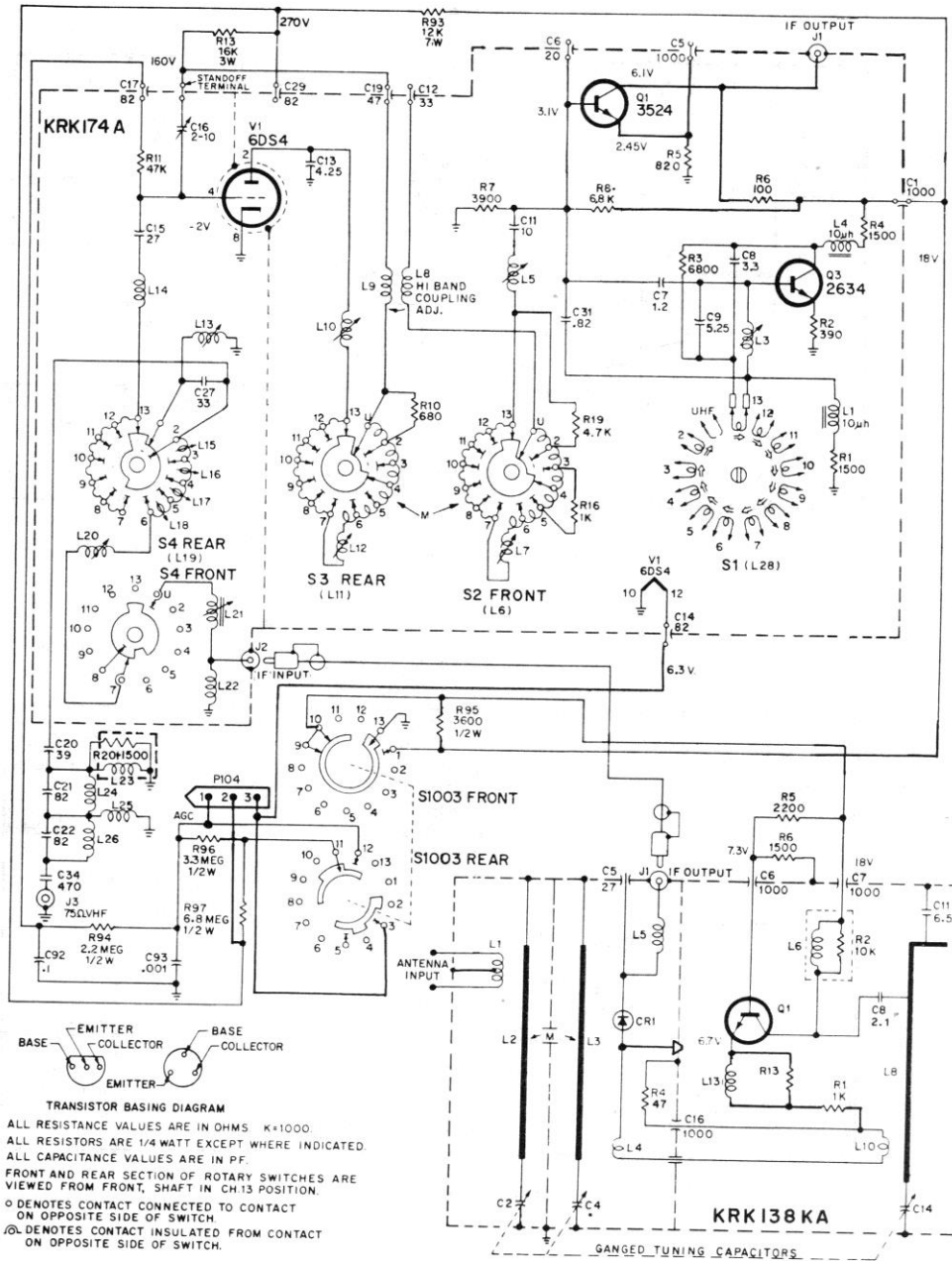

**TMA 402 AC, XZ LAYOUT AND EXTERNAL WIRING**

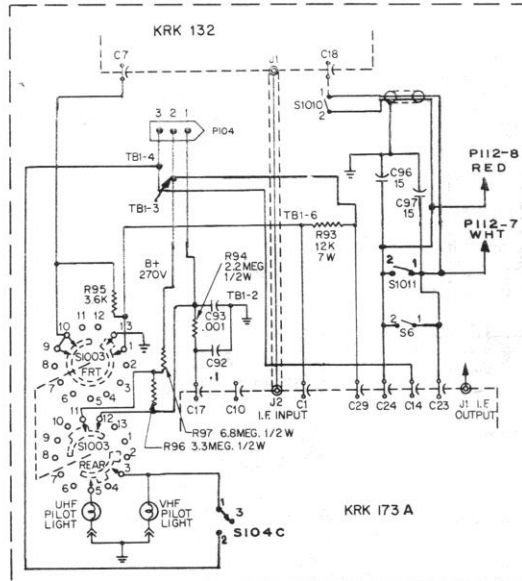

External Wiring Diagram

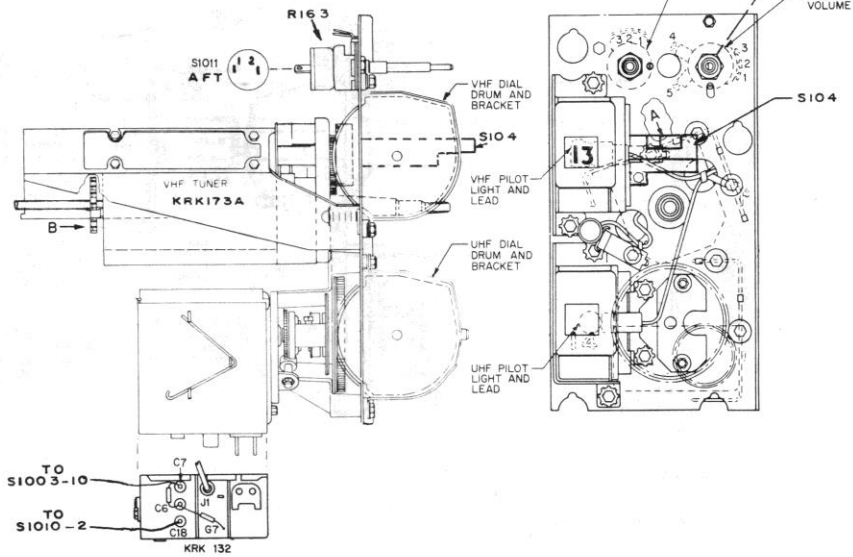
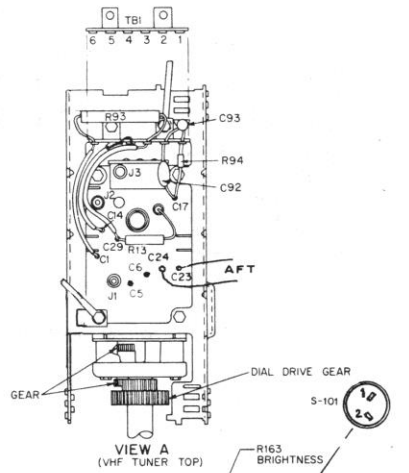
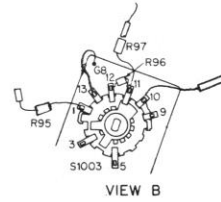

TMA 402 AD, XZR LAYOUT AND EXTERNAL WIRING

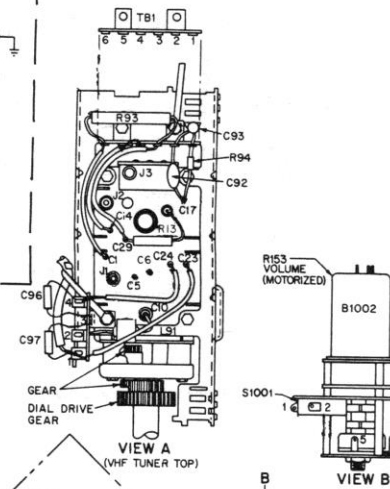
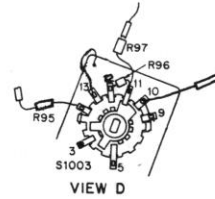
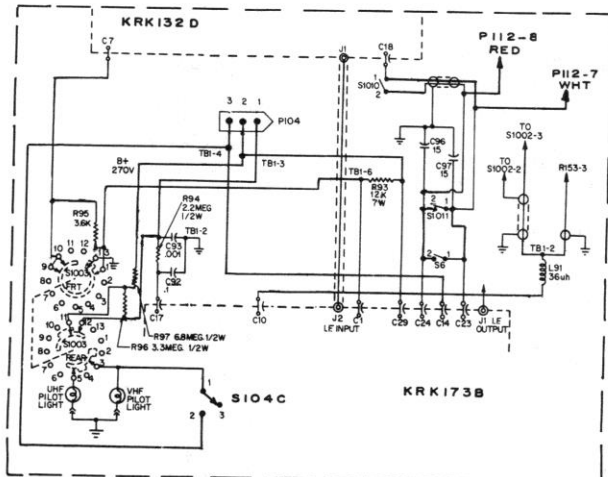

External Wiring Diagram

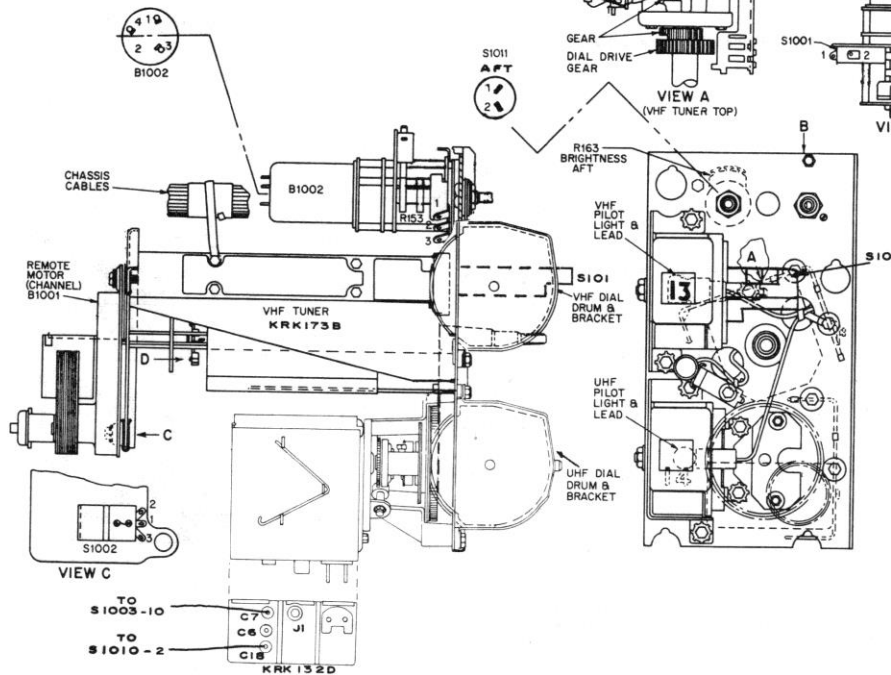

CTP11H REMOTE AMPLIFIER SCHEMATIC DIAGRAM

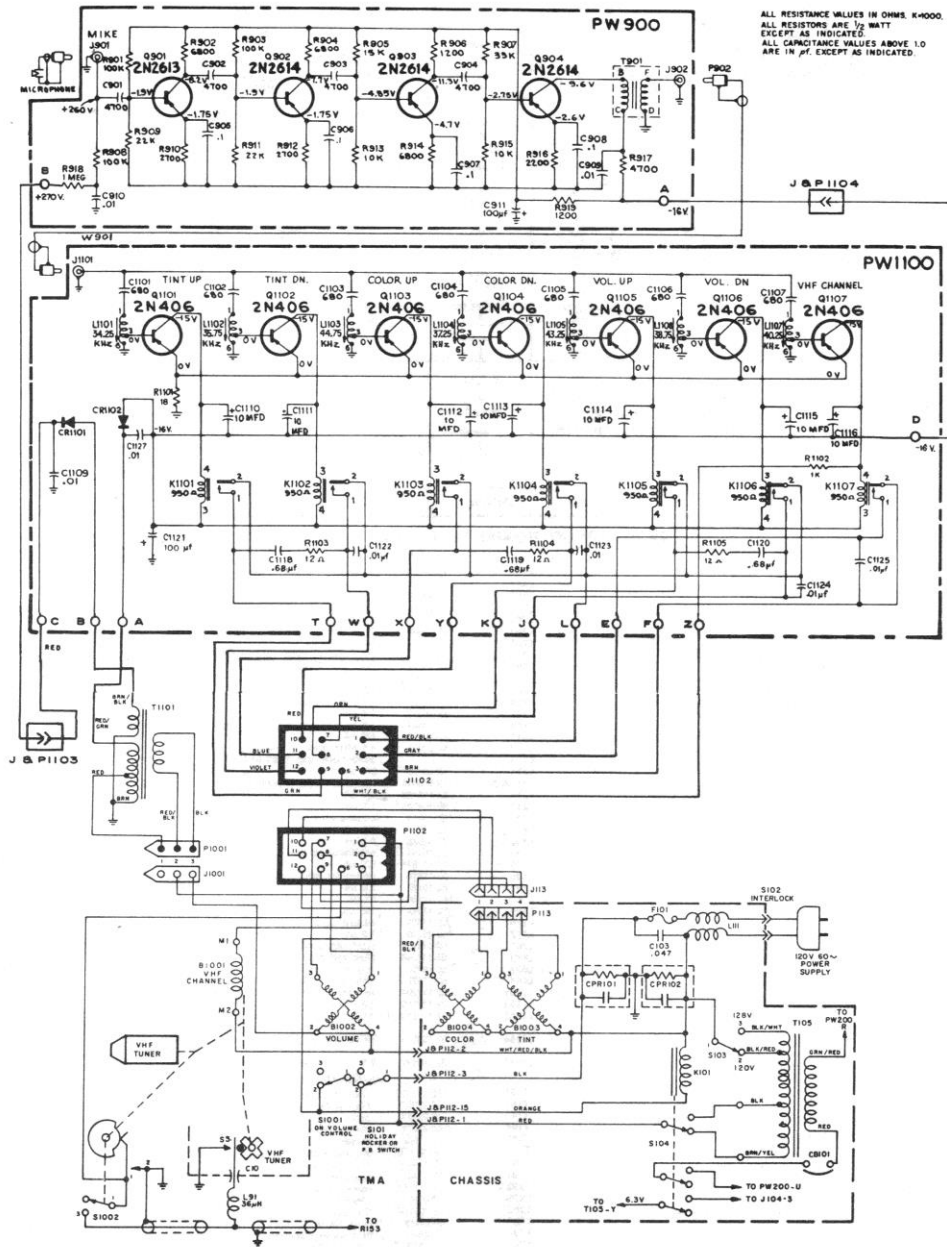

ALL RESISTANCE VALUES IN OHMS, K=1000,  
ALL RESISTORS ARE 1/2 WATT  
EXCEPT AS INDICATED.  
ALL CAPACITANCE VALUES ABOVE 1.0  
ARE IN  $\mu$ F, EXCEPT AS INDICATED.

CRK9C REMOTE TRANSMITTER SCHEMATIC

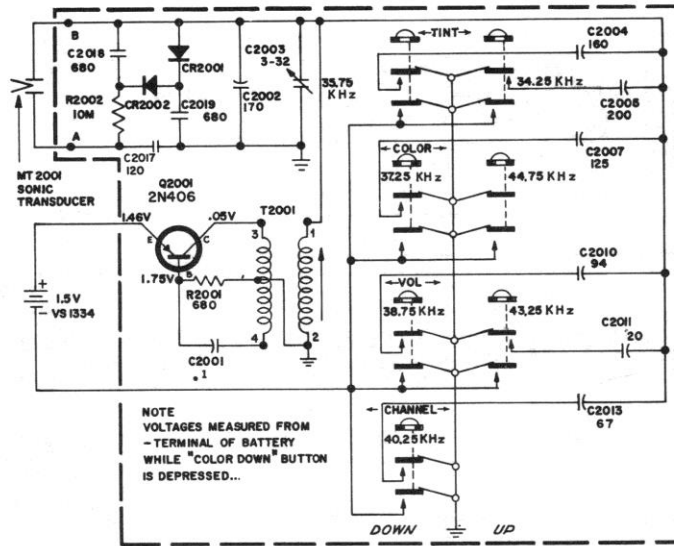

CRK9C CIRCUIT BOARD ASSEMBLY

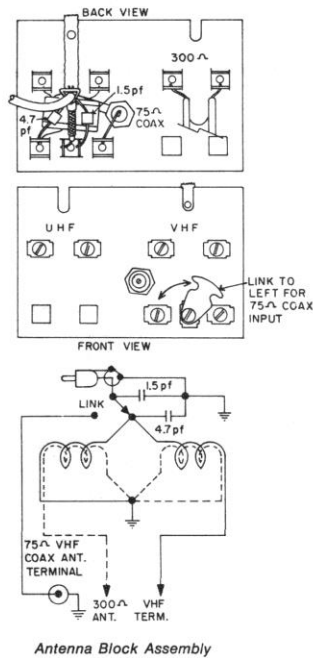

COILS

L105	62-15182	RF choke, 5.6 uH.
L107	62-17775	top and bottom pin phase
L109	*62-124807	filter choke
L111	62-20570	choke, AC line filter
L201	62-20226	47.25 MHz. trap
L202	62-18947	41.25 MHz. trap
L203	62-21159	second pix IF
L204	*62-22067	third pix IF, input (includes L213)
L205	62-20229	third pix IF, output
L206	62-20230	12 uH.
L207	62-116507	3.9 uH.
L208	62-20231	41.25 MHz. trap
L209	62-109171	5.6 uH.
L210	62-109248	1.8 uH.
L211	62-100131	120 uH.
L212	62-20232	4.5 MHz. trap
L213		39.75 MHz. trap (part of L204)
L214	62-20439	270 uH.
L215A,B	62-116506	horizontal frequency/sine wave
L216	62-115438	220 uH.
L217	62-109248	1.8 uH.
L701	62-20233	chroma take off
L702	62-17737	620 uH.
L703	*62-22070	6.8 uH.
L704	62-19031	oscillator screen
L705	62-17737	620 uH.
L706	62-19378	horizontal efficiency
L707	62-15182	5.6 uH.
L708	62-17738	27 uH.
L709	62-19515	120 uH.
L710	62-19035	mutual coupling
L712	*62-22069	8.2 uH.
L801	62-21313	right red/green vertical lines
L802	62-114598	right red/green horizontal lines
L803	62-18050	blue horizontal shape
L804	62-17478	right blue horizontal lines
L1301	62-122204	46.1 MHz. trap (CTC39XA, XB, XZ, XZR)
L1302	62-122205	3.3 uH. (CTC39XA, XB, XZ, XZR)
L1303	62-122213	AFTC discriminator primary, 46.1 MHz. (CTC39XA, XB, XZ, XZR)
L1304	62-122203	AFTC discriminator secondary, 45.75 MHz. (CTC39XA, XB, XZ, XZR)
L1305	62-109171	5.6 uH. (CTC39XA, XB, XZ, XZR)

TRANSFORMERS

T101	62-113999	coil, focus adjustment
T102	*62-22253	high voltage
T103	62-21153	audio output
T104	*62-22174	vertical output
T105	62-18902	power
T107	62-121560	top and bottom pin cushion
T108	62-17867	side pin cushion
T201	62-20265	sound take off
T202	62-118738	sound driver
T203	62-20266	quadrature
T204	62-127244	first pix IF
T205	62-20268	third pix IF, output
T701	62-20269	first chroma bandpass
T702	62-20270	burst amplifier
T703	62-18676	3.58 MHz. oscillator
T705	62-20271	second chroma bandpass

**CTP 11 REMOTE RECEIVER ALIGNMENT**

**TEST EQUIPMENT CONNECTIONS:**

**GENERAL**

The illustration below indicates adjustment points 1 through 7 and the corresponding frequency and function to be adjusted. Depress the appropriate transmitter function button as shown below and hold depressed while peaking each coil (L1101 to L1107).

**SIGNAL SOURCE**

A CRK 9 transmitter checked for accuracy by the beat frequency method, or checked with a CTP 11 receiver known to be correctly adjusted, may be used as a signal standard.

**TRANSMITTER**

The transmitter distance selected, should provide a maximum VTVM reading of approximately +7 volts peak. Or, a strip of tape may be placed over all or part of the transmitter transducer and adjusted to provide the correct attenuation.

**VACUUM TUBE VOLTMETER**

Adjust the VTVM on the +15 volts DC scale, and connect the ground lead to terminal D (noted below). Then progressively connect the meter probe across each relay coil during the alignment procedure.

**ALIGNMENT PROCEDURE**

STEP	TRANSMITTER OUTPUT FREQUENCY	TRANSMITTER FUNCTION BUTTON	VTVM CONNECTION	ADJUST FOR MAXIMUM	
1	Adjust up tint	34.25kHz	Depress and hold Tint up	D to K1101-4	L1101
2	Adjust down tint	35.75kHz	Depress and hold Tint down	D to K1102-3	L1102
3	Adjust up color	44.75kHz	Depress and hold Color up	D to K1103-3	L1103
4	Adjust down color	37.25kHz	Depress and hold Color down	D to K1104-3	L1104
5	Adjust up volume	43.25kHz	Depress and hold Volume up	D to K1105-3	L1105
6	Adjust down volume	38.75kHz	Depress and hold Volume down	D to K1106-3	L1106
7	Adjust Channel Selector	40.25kHz	Depress and hold Channel	D to H	L1107

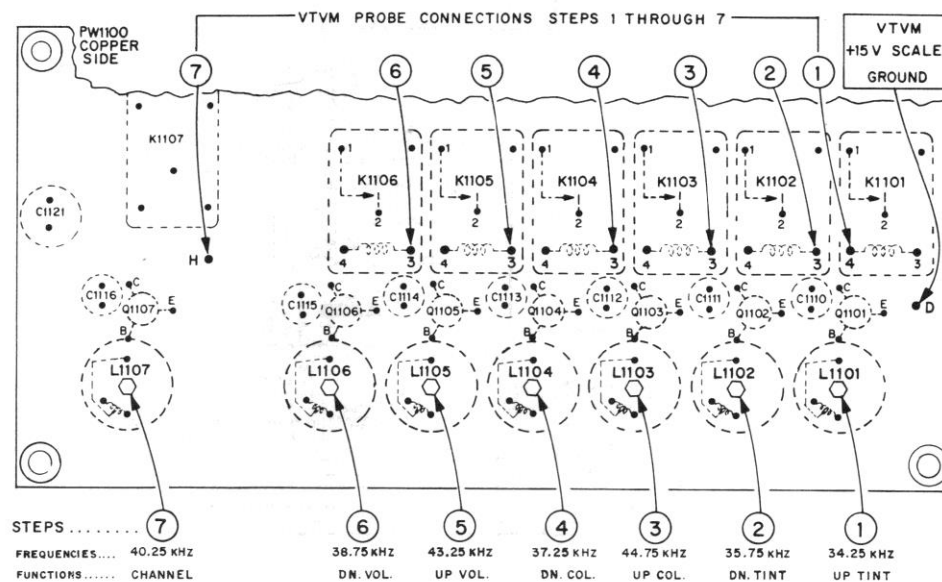



**CRK 9 TRANSMITTER ALIGNMENT**

**TEST EQUIPMENT CONNECTIONS:**

**GENERAL**

When depressing function buttons, depress fully and hold depressed as adjustment is made.

**SIGNAL SOURCE**

A separate CRK 9 transmitter, checked for accuracy and proper operation, is recommended as a signal standard to be used in aligning the transmitter. (Transmitters used as standard should be checked frequently against a crystal standard or several receivers known to be operating properly.)

**TRANSMITTER STANDARD**

Remove the complete back cover from the transmitter. Loosely couple the transmitter to the Horizontal Input of the oscilloscope. To do this, place the probe of the oscilloscope approximately one inch in front of the transducer opening at the end of the transmitter. Ground the oscilloscope to the negative terminal of the battery.

**TRANSMITTER BEING ALIGNED**

Remove the complete cover from the transmitter. Loosely couple the transmitter to the Vertical Input of the oscilloscope. Place the probe of the oscilloscope approximately one inch in front of the transducer opening at the end of the transmitter. Keep the transmitter being aligned about two feet from the transmitter standard. Ground the oscilloscope to the negative terminal of the battery.

**OSCILLOSCOPE**

Connect as shown below.

**ELECTRICAL SPECIFICATIONS**

Transmitter shall be tuned at only one frequency (44.750kHz). None of the other function frequencies are adjustable.

**ALIGNMENT**

Press the "Color Up" button and adjust C2003 for 44.750kHz  $\pm$ 20Hz. All other function frequencies shall be within  $\pm$ 150Hz of that listed in table below.

NOTE: Oscillator pre-set and sealed at factory.

Fundamental Frequencies		
FUNCTION	UP	DOWN
Tint	34,250	35,750
Color	44,750	37,250
Volume	43,250	38,750
Channel	40,250	

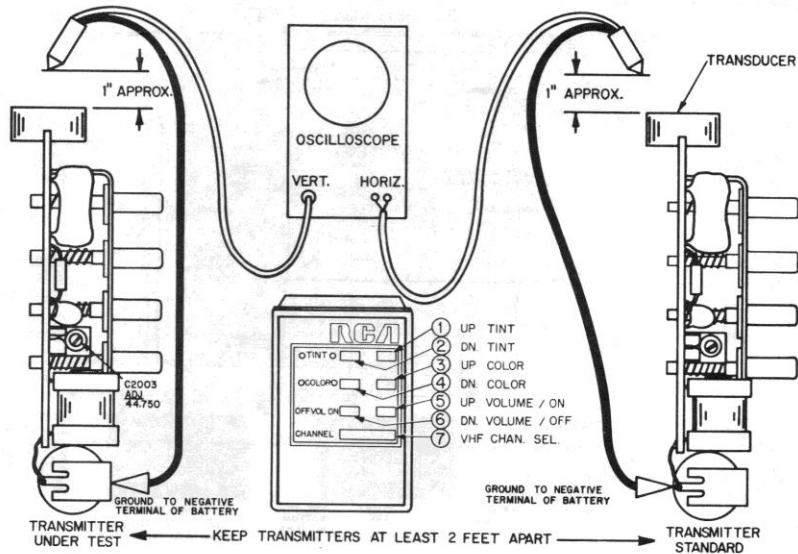

CHASSIS LAYOUT

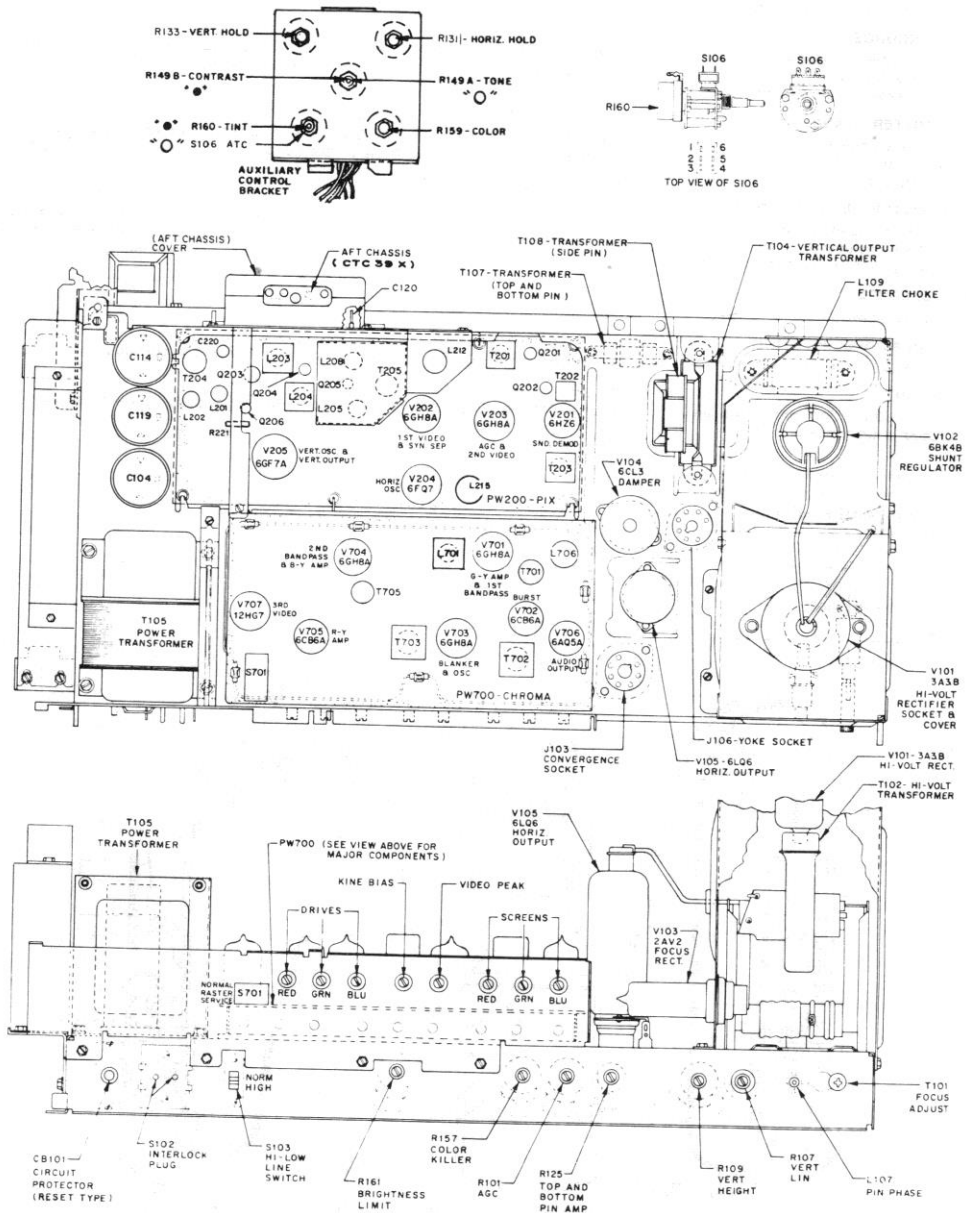

PW200 CIRCUIT BOARD ASSEMBLY

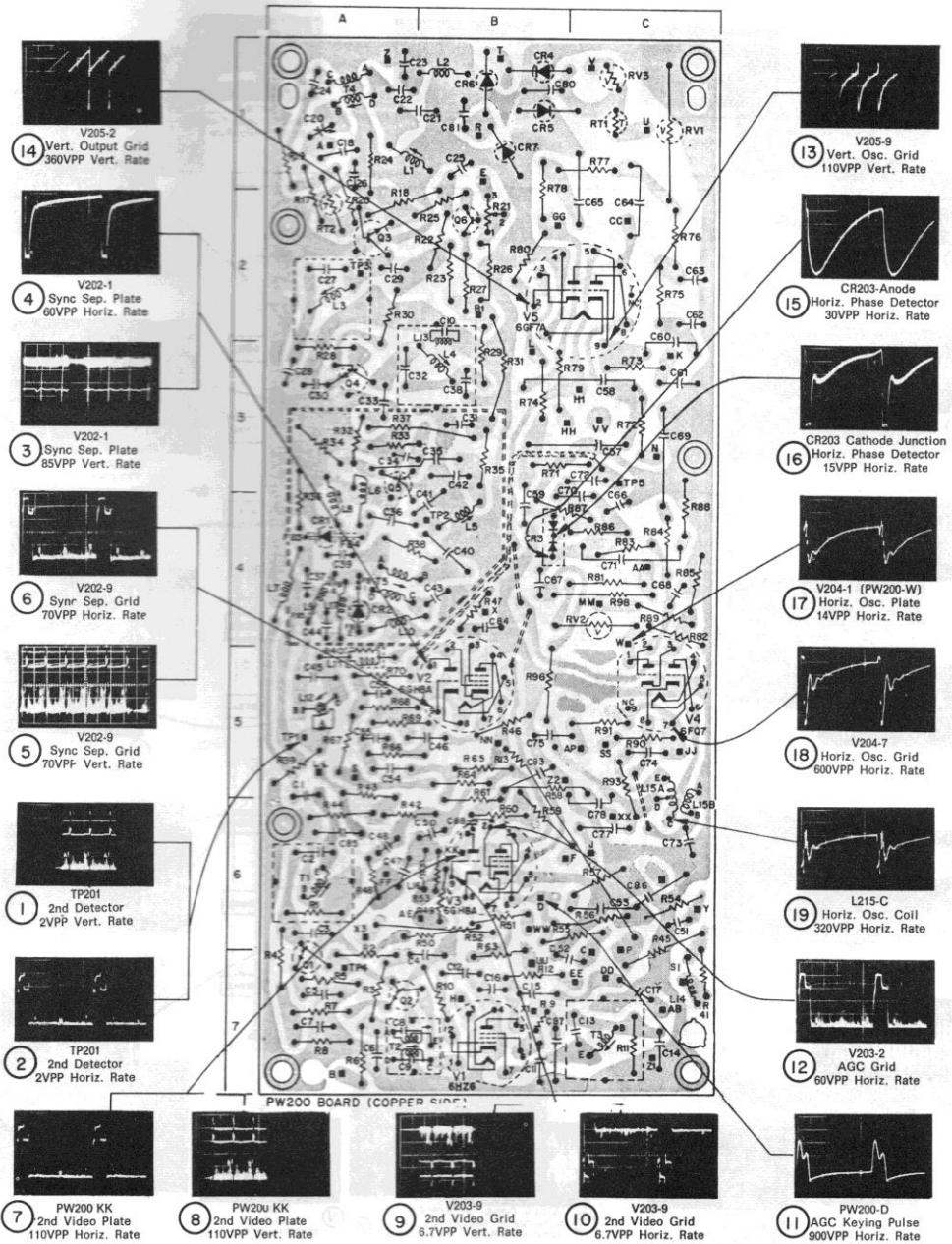

PW700 CIRCUIT BOARD ASSEMBLY

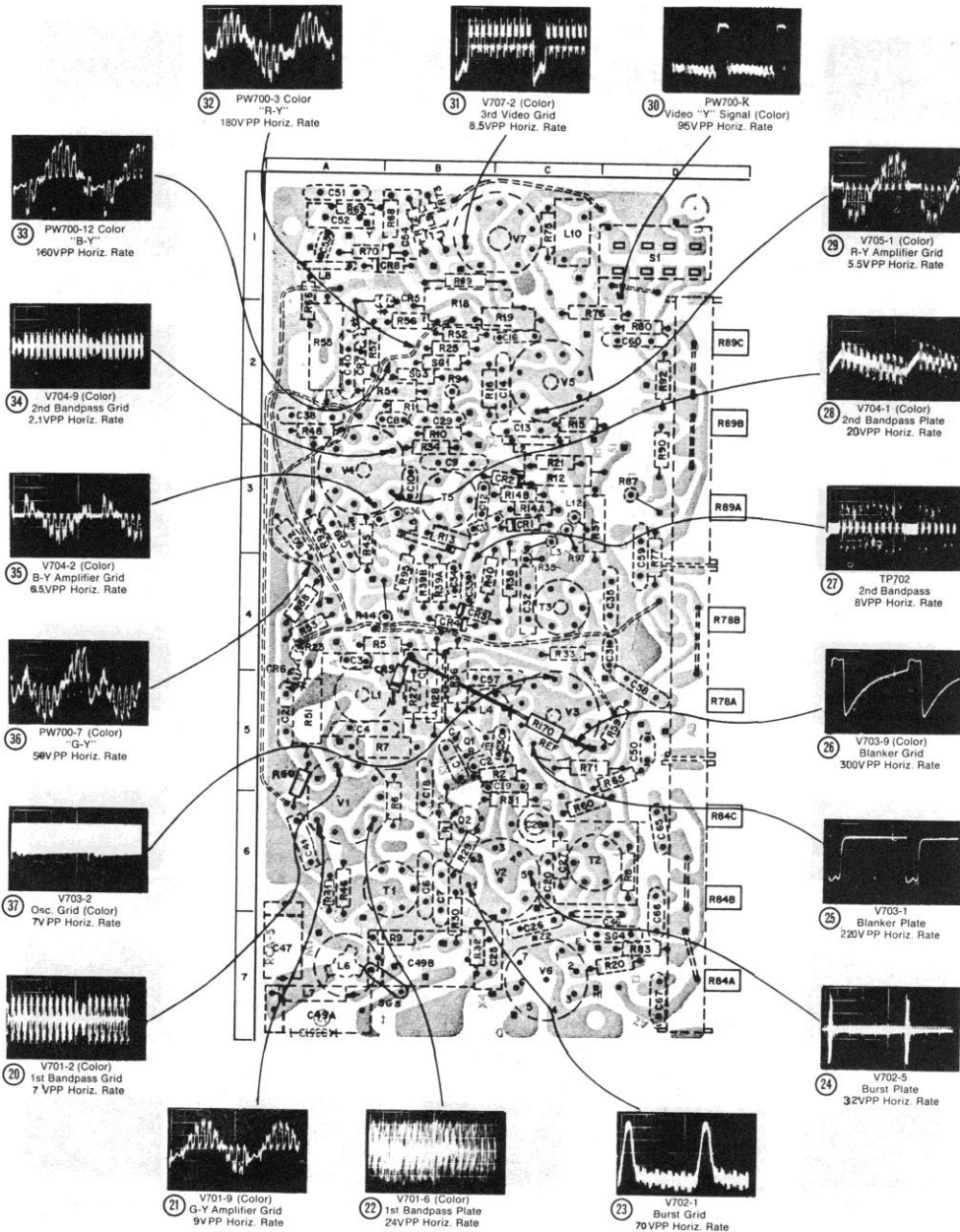

PW800 CONVERGENCE BOARD CIRCUIT ASSEMBLY

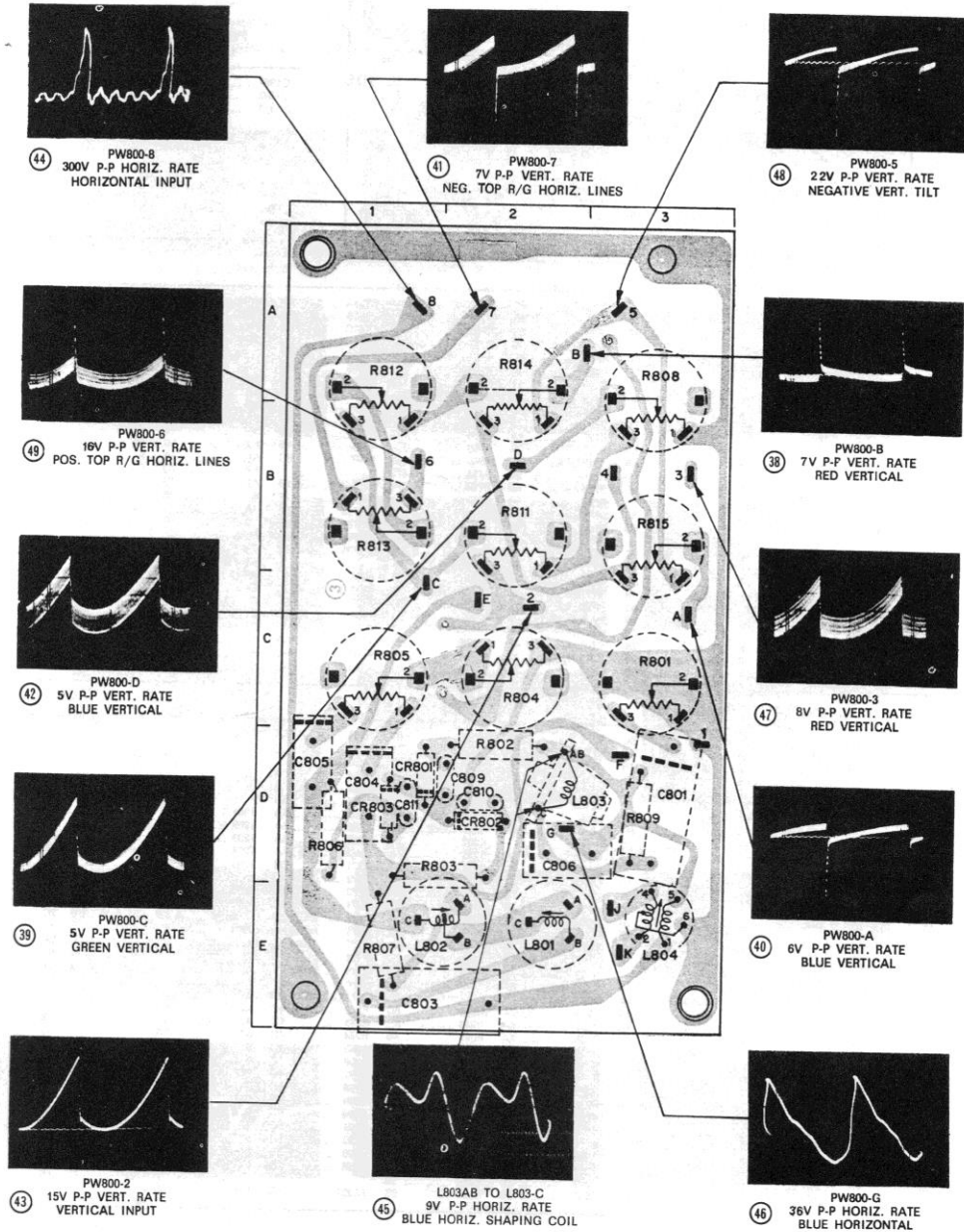

PW1300 AFT CIRCUIT BOARD ASSEMBLY

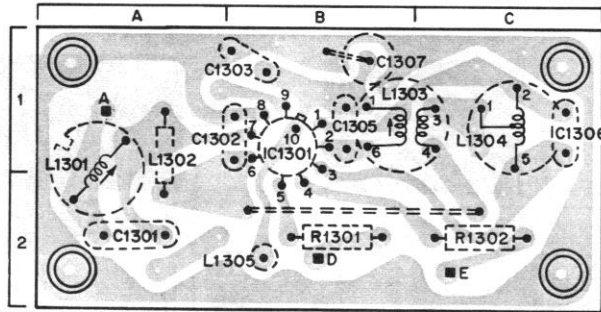

PW1300 COMPONENT LOCATION GUIDE

C1301	2A	L1303	1B
C1302	1B	L1304	1C
C1303	1B	L1305	2B
C1305	1B	R1301	2B
C1306	1C	R1302	2C
C1307	1B		
IC1301	1B	A	1A
L1301	1A	D	2B
L1302	1A	E	2C

PW700 COMPONENT LOCATION GUIDE

C701	5B	C735	4D	CR707	2A	R712	3C	R746	6A	R784A	7D	V704	3A	J	7B
C702	5C	C736	3B	CR708	1B	R713	3B	R748	3A	R784B	6D	V705	2C	K	1D
C703	4A	C738	2A	CR709	4B	R714A	3C	R750	5A	R784C	6D	V706	7C	KB	3B
C704	5A	C739	3A			R714B	3C	R751	5A	R787	3D	V707	1C	L	6D
C706	6B	C740	2A	L701	5A	R715	2C	R752	2B	R789A	3D			LB	5C
C707	6B	C741	6A	L702	3C	R716	2C	R753	4A	R789B	2D	A	4A	M	4C
C708	2B	C746	7D	L703	3C	R718	1B	R754	2B	R789C	2D	AA	7D	MI	7A
C709	3B	C747	7A	L704	5C	R719	2C	R755	2A	R790	3D	AB	5D	N	5D
C710	3B	C749A	7A	L705	3B	R720	7D	R756	2B	R792	2D	AD	7B	P	5C
C711	3C	C749B	7B	L706	7A	R721	3C	R757	2A	R793	3A	AE	1A	O	3D
C712	3B	C750	5D	L707	7A	R723	4A	R758	4A	R794	2B	AF	1B	R1	3C
C713	2C	C751	1A	L708	7A	R725	2B	R759	5D	R795	4B	AJ	1C	R2	5C
C714	2C	C752	1A	L709	1B	R727	5B	R760	6C	R797	3C	AL	4A	S	5C
C716	2C	C753	1A	L710	1C	R728	5B	R765	5D			AP	1D	S1	3D
C717	5B	C754	1B	L712	3C	R729	6B	R766	1A	S701	1D	AZ	7D	T	7B
C718	5B	C757	5C			R730	6B	R767	1B	SG701	2B	B	2B	U	1B
C719	5C	C758	5D	O701	5B	R731	6C	R768	1B	SG702	3A	BA	1B	V	6B
C720	6C	C759	4D	O702	6B	R732	7B	R769	1A	SG703	2B	BB	2D	W	6B
C721	5A	C760	2D			R733	4C	R770	1A	SG704	7D	BG	4B	X	2C
C725	7C	C765	6D	R170	5C	R734	3B	R771	5C	SG705	7B	BH	6B	X2	3B
C726	7C	C766	6D	R701	6B	R735	4C	R772	1B			BJ	5C	X3	3A
C727	6C	C767	7D	R702	5C	R736	5B	R773	1B	T701	6B	BK	5D	X4	7C
C728	6C			R705	4B	R737	3C	R775	1C	T702	6D	BL	1A	V	1A
C729	2B	CR701	3C	R706	6B	R738	4C	R776	2D	T703	4C	C	5A	Z	4D
C730	5C	CR702	3C	R707	5B	R739A	4B	R777	4D	T705	3B	D	7C	Z1	6B
C731	4D	CR703	4B	R708	6D	R739B	4B	R778A	5D			E	7C	Z2	7C
C732	4C	CR704	4B	R709	7B	R740	4C	R778B	4D	V701	6A	F	4D	TP1	7C
C733	4B	CR705	1B	R710	3B	R744	4B	R790	2D	V702	6C	H	4B	TP2	4B
C734	4B	CR706	4A	R711	2B	R745	3A	R793	7D	V703	5C	H1	7C		

PW200 COMPONENT LOCATION GUIDE

C201	6A	C238	3B	C277	6C	L211	5A	R224	1A	R260	6B	RT202	2A	H1	3C
C202	6A	C239	4A	C278	6C	L212	5A	R225	2B	R261	6B			J	6C
C203	6A	C240	4B	C280	1B	L213	2B	R226	2B	R263	7B	RV201	1C	JJ	5C
C204	7B	C241	4B	C281	1B	L214	7A	R227	2B	R264	5B	RV202	4C	K	3C
C205	7A	C242	3B	C283	5B	L215A	5C	R228	3A	R265	5B	RV203	1C	KK	6B
C206	7A	C243	4B	C284	4B	L215B	6C	R229	3B	R266	3B			L	3B
C207	7A	C244	4A	C285	6A	L216	6B	R230	2A	R267	5A	T201	6A	LI	5A
C208	7A	C245	5A	C286	6C	L217	4A	R231	3B	R268	5A	T202	7A	MM	4C
C209	7A	C246	5B	C287	7B			R232	3A	R269	5A	T203	7C	N	3C
C210	7B	C248	6A	C288	6B	O201	7A	R233	3A	R270	5A	T204	1A	NN	5B
C211	7B	C250	6B			O202	7A	R234	3A	R271	3B	T205	4A	P	6C
C212	7C	C251	6C	CR201	4A	O203	2A	R235	3B	R272	3C			R	1B
C213	7C	C252	7C	CR202	4A	O204	3A	R236	4A	R273	3C	V201	7B	S	5A
C214	7C	C253	6C	CR203	4B	O205	3A	R237	3B	R274	3B	V202	5B	SS	5C
C215	7B	C254	5A	CR204	1B	O206	2B	R238	4A	R275	2C	V203	6B	S1	7C
C216	7B	C255	5A	CR205	1B			R239	5A	R276	2C	V204	5C	T	1B
C217	7C	C256	5A	CR206	1B	R201	6A	R240	5A	R277	1C	V205	2C	TP1	5A
C218	1A	C257	3C	CR207	1B	R202	7A	R241	7C	R278	2B			TP2	4B
C220	1A	C258	3C			R203	7A	R242	6A	R279	3B	H	1A	TP3	2A
C221	1B	C259	4B	FB201	4A	R204	7A	R243	5A	R280	2B	AA	4C	TP4	7A
C222	1A	C260	3C	FB202	4A	R205	7A	R244	6A	R281	4C	AB	7C	TP5	3C
C223	1A	C261	3C	FB203	4A	R206	7A	R245	6C	R282	4C	AE	6B	U	1C
C224	1A	C262	2C	FB204	4A	R207	7A	R246	5B	R283	4C	AP	5C	UU	7B
C225	1B	C263	2C	FB205	4A	R208	7A	R247	4B	R284	4C	B1	7A	V	1C
C226	1A	C264	2C	FB206	4A	R209	7B	R248	6A	R285	4C	B1	2B	VV	3C
C227	2A	C265	2C			R210	7B	R249	6B	R286	4C	C	6C	W	4C
C228	3A	C266	4C	L201	1A	R211	7C	R250	6B	R287	4C	CC	2C	WW	6B
C229	2A	C267	4B	L202	1B	R212	7B	R251	6B	R288	4C	D	6B	X	4B
C230	3A	C268	4C	L203	2A	R213	6B	R252	6B	R289	4C	DD	7C	X1	7B
C231	3B	C269	3C	L204	3B	R217	2A	R253	6B	R290	5C	E	1B	X3	6A
C232	3A	C270	4C	L205	4B	R218	2A	R254	6C	R291	5C	EE	7C	XX	7C
C233	3A	C271	4C	L206	4A	R219	1A	R255	6C	R293	5C	F	6C	Y	6C
C234	3A	C272	3C	L207	4A	R220	2A	R256	6C	R296	5B	FF	6A	Z	1A
C235	3B	C273	6C	L208	4A	R221	2B	R257	6C	R298	4C	GG	2B	Z1	7C
C236	4A	C274	5C	L209	4A	R222	2B	R258	5B			H	7B	Z2	5B
C237	4A	C275	5B	L210	4A	R223	2B	R259	6B	RT201	1C	HH	3C		



PICTURE TUBE GRID WAVEFORMS

The series of 18 waveforms below illustrate the demodulator gain and phase-angle changes resulting from the ACCU-TINT circuits. These were taken with a color bar pattern furnished by a WR-64B color-bar generator. Conditions of nominal phase,  $+30^\circ$ , and  $-30^\circ$  are represented with the color circuits operating first with A-T "OFF" and second with A-T "ON".

