

**TECHNICAL MANUAL**  
**for**  
**INSTALLATION and MAINTENANCE**

**of**  
**SETCHELL-CARLSON**

**UNIT-IZED** **COLOR** TELEVISION

*for the splendor of COLOR*

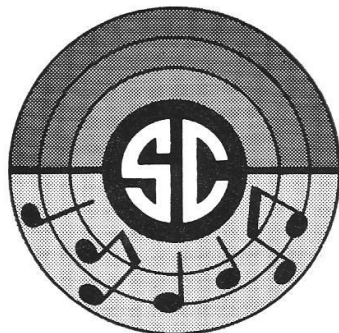

*for true fidelity in SOUND*

**UNIT-IZED Chassis U800**

**FOR PROFESSIONAL USE ONLY**

Manufactured by SETCHELL-CARLSON, INC., New Brighton, St. Paul, Minn. 55112

### TO THE TECHNICIAN:

The purpose of this booklet is to aid the technician in set-up, adjustment and maintenance of Setchell-Carlson UNIT-IZED Color Television Receivers.

The exclusive Setchell-Carlson UNIT-IZED chassis design consists of an aluminum chassis on which seven finely engineered plug-in units are mounted. Each unit may be individually removed or replaced for quick, easy test or maintenance.

UNIT-IZED design simplifies servicing since localizing difficulty has been reduced from the tedious and costly job of checking hundreds of individual parts, to a simple substitution of one of the plug-in units in the home. A panel under the chassis is also removable for testing or maintenance.

PRACTICALLY ALL SET-UP, CONVERGENCE AND ADJUSTMENT CONTROLS ARE DELIBERATELY ENGINEERED TO BE ACCESSIBLE TO THE TECHNICIAN FROM THE FRONT OF THE TELEVISION RECEIVER (via front opening service panel) SO THAT SET-UP, ADJUSTMENT AND MAINTENANCE ARE FASTER, EASIER AND MUCH MORE ACCURATE.

UNIT-IZED construction facilitates rapid, inexpensive modernization.

### WARNING

Extremely high voltages are present in the color television receiver. Only qualified technicians, thoroughly familiar with high voltage precautions, should service the receiver.

Exercise necessary precautions when making measurements or handling picture tube. Do not attempt to remove picture tube, high voltage unit CF-1 or chassis before discharging the picture tube second anode, anode lead, and other points where high voltages exist.

### INSTALLATION

After the color television receiver has been placed in the position in which it is to be viewed, demagnetize the picture tube face plate area. Check purity, convergence, monochrome tracking, height, linearity, focus, etc. Procedures are given under "Adjustments".

COLOR TELEVISION RECEIVERS LEAVING THE FACTORY ARE ADJUSTED BY EXPERTS WHO SPECIALIZE IN THE SET-UP OF UNIT-IZED COLOR TV.

It is seldom necessary to go through a complete "set-up" routine when installing a new color receiver. If observation of the picture displayed indicates a "touch-up" of adjustment(s) is necessary, perform them with the receiver in the location in which it will be viewed, as stated in procedures listed under "Adjustments". Relocating the receiver will necessitate demagnetizing the picture tube and checking purity and convergence for possible "touch-up".

### LOCATING THE INSTRUMENT

Place the color receiver where no bright light will fall directly across the screen. Sunlight or room light falling directly onto the face plate of the picture tube will "wash out" the colors... causing them to appear weak or faded. Arrange the viewing distance to approximately 8 feet and, if possible, facilities for darkening the room for best viewing comfort are desirable.

Reproduction of black-and-white pictures on a color television receiver are not as bright as a monochrome receiver since the amount of light output from a normal color tube is less.

Avoid placing the color television receiver near heat sources such as radiators, or in front of heating vents. The picture tube cup prevents the receiver from being placed too close to walls.

Antenna rotators, electric clocks, telephones, etc., should not be placed on top of the television receiver since undesirable effects may be produced in the picture by such placement.

### **ANTENNA REQUIREMENTS**

Antennas used for black-and-white reception may or may not be adequate for good color reception since requirements for best color reception include broad bandwidth and essentially flat frequency response across the range of channels. Indoor or built-in types are not suitable.

Installation of a new antenna requires extreme care in orientation and dressing lead-in wire. Orientation during a colorcast is recommended to insure best color reception.

Wide variation in directions of reception from different stations may require an antenna rotator.

Multiple distribution systems and TV boosters (in many instances) lack adequate bandwidth and response characteristics for acceptable color reception. This should be checked before installing or connecting the color TV.

In strong signal areas, it may be necessary to place an attenuator pad in series with the antenna input in order to prevent cross-talk between channels. A simple pad may be made up of three half-watt resistors...560 OHMS shunting the antenna and 150 OHMS in series with each leg to the antenna terminals of the receiver. Such a pad also helps to maintain a proper impedance match between transmission line and the tuner.

### **INSTRUCTING THE CUSTOMER**

After installation has been completed, the operating instructions should be reviewed carefully with those who will be operating the receiver (see Owner's Manual packed with each color TV receiver).

Review of operation should be made during a color program or with a color bar generator.

The customer should also be advised that the quality of the color program is dependent on the type of broadcast since "live" indoor, "live" outdoor, "on film" or "video tape" vary in quality; also, source of origination varies reception quality.

### **ADJUSTMENT OF NEW COLOR TELEVISION RECEIVERS**

#### **ADJUST THE PRE-SET VHF FINE TUNING**

1. Turn the receiver on, and allow it to warm up.
2. Set MICRO-TUNING control to approximately one-half (center) of its rotation.
3. Select your VHF station by turning VHF CHANNEL SELECTOR.
4. Remove VHF CHANNEL SELECTOR knob by pulling forward.
5. Push-in and rotate exposed knurled Fine Tuning Ring for best picture. Dis-engage Fine Tuning Ring by pulling out to original position.
6. Replace CHANNEL SELECTOR knob and turn to next channel where reception is available.
7. Repeat steps 4, 5 and 6 until all VHF channels where reception is available are adjusted.

MICRO-TUNING may then be used for adjusting tuner for extra-quality color and black-and-white reception.

#### UHF TUNING AND MICRO TUNING (Models equipped with UHF Tuner)

1. Turn the receiver on, and allow it to warm up.
2. Set MICRO-TUNING control to approximately one-half (center) of its rotation.
3. Select your UHF station with UHF CHANNEL SELECTOR. After reaching the desired UHF channel, rotate the UHF Selector knob SLOWLY back and forth until interference disappears and picture is clear.
4. Adjust MICRO-TUNING for best picture. Slight re-adjustment may be required after prolonged operation.

#### ADJUST THE RECEIVER FOR A BLACK-AND-WHITE PICTURE

Check the horizontal oscillator adjustment, focus, height, vertical linearity, width, and electrical centering. Observe the picture for good black-and-white reproduction over all areas of the screen. No objectionable color shading should be evident. If shading is evident, demagnetize the instrument.

It is seldom necessary to go through a complete "set-up" routine when installing a new color receiver. In the majority of cases, a technician needs only to degauss the face plate area of the picture tube and touch up the convergence.

Color television receivers leaving the factory are adjusted by experts who specialize in the set-up of color receivers. There is no reason why picture tube temperature, or even dynamic convergence, should shift during delivery. However, since a receiver, or parts of it, may become magnetized as it is transported from one location to another, it is very important to demagnetize the picture tube face plate area once the receiver is set in its final operating position.

#### TO USE THE DEMAGNETIZING COIL

Slowly move the coil around the front face plate of the picture tube and around the sides and front of the receiver; then slowly withdraw the coil to a distance of at least six (6) feet from the receiver before disconnecting the coil from the AC source.

#### LOW VOLTAGE CIRCUIT PROTECTION

A reset-type of circuit breaker (located on rear of Unit CG-1 on top of main chassis) is incorporated in the power supply. To reset the breaker, push the red button all the way "in" and release.

### ACCESS TO SET-UP & SERVICE CONTROLS

(Service panel is located below picture tube and is hinged at the bottom, opening forward to give access to controls). To open, proceed as follows:

PLACE LEFT HAND UNDER CENTER OF MOLDING BELOW PICTURE TUBE, AND LOCATE FLAT LOCKING SPRING. PUSH UP TO RELEASE PANEL, AND.....

PLACE FINGERS OF RIGHT HAND UP INTO MACHINED SLOT UNDER CENTER OF MOLDING AT BOTTOM OF CABINET. PRESS FINGERS AGAINST BACK OF PANEL TO TIP PANEL FORWARD.

#### ACCESS PANEL ON CABINET BOTTOM

Voltage readings or minor service to the chassis may be made without removing the chassis from the cabinet.

The cabinet may be laid on its side and the entire chassis bottom exposed by removing the screened panel. Four screws hold the panel in place. NOTE: When the cabinet is turned on its side, the earth's magnetic field will upset purity and focus of the picture tube. In this position, appearance of the image must be disregarded and adjustments made only after the cabinet has been turned upright.

#### PLATE SUPPLY VOLTAGE DIVISION

Four different positive plate supply voltages are used in the receiver.

1. 405 v.: The filter capacitor for this supply is located in Unit CF-1.
2. 380 v. for vertical output tube only: Filter capacitor is located on front lip of main chassis.
3. 260 v.: This voltage is obtained by dropping the 405 v. supply through a 2000 ohm 15 watt resistor located in Unit CC-1. The associated filter capacitor is on the front lip of the chassis.
4. 140 v.: Filter capacitor is located on Unit CD-1.



## PICTURE TUBE PROTECTOR

A separate 8.3 volt secondary winding of the power transformer (see Unit CG-1) furnishes heater power for the 6BK4 regulator and for the picture tube. This circuit is held at a voltage of about 260 volts above ground in order to minimize cathode leakage in the associated tubes. The 8.3 volt supply is dropped to the normal 6.3 volts for the 6BK4 by resistor R520 in Unit CF-1. A one-ohm dropping resistor for the picture tube heaters is mounted under the rear of the main chassis and may be reached by removing the plate marked "Picture Tube Protector." This resistor not only protects the picture tube heaters from warm-up surge, but may be shunted to provide a "booster" for an aged and weak picture tube. A wire may be soldered across the resistor terminals without removing the chassis. **WARNING:** The booster should be used only to extend the life of a tube in which emission of one or more guns has dropped so low that satisfactory performance cannot be obtained at normal heater voltage. When a new picture tube is installed, be sure to check this resistor, and remove the shunt if previously installed.

## BALANCED HEATER SUPPLY

The heater supply to all tubes, other than the picture tube and the 6BK4, is divided in such a way that a portion of the load is carried by each side of a center-tapped 12.6 volt winding with tap grounded. The loads for each side are almost completely balanced, so that AC current loops through the chassis return have been eliminated. The chroma Unit (CY-1) is itself divided, receiving heater power from both sides of the winding, so that the balance is not upset when the chroma Unit is removed from the chassis. This system prevents ripple that might be caused by excessive AC current flow through the chassis.

## CY-1 (CHROMA) UNIT:

A faulty chroma (CY-1) Unit may prevent reception of both black-and-white and color pictures. Normal black-and-white reception, however, can be obtained with the CY-1 Unit removed from the receiver. If Unit is removed, it is usually necessary to readjust kine bias, screen, and cathode-drive controls (normal color temperature adjustments). Color temperature adjustment may also be required if CY-1 Units are exchanged, or if tubes are changed in normal service.

## PICTURE TUBE REMOVAL AND REPLACEMENT

1. After removal of the chassis, tilt the cabinet forward and carefully set it face down on a suitable pad. (See chassis page for details.)
2. Slide the blue lateral magnet from the tube neck. Remove the ground clip from the purity shield. Remove the purity magnet assembly.
3. Slide the convergence magnet assembly off the tube neck and place it carefully in the front of the cabinet. Loosen the yoke mounting clamp screw and remove the yoke.
4. Remove the picture tube purity shield held by the screws near each corner. Remove the bolts securing the four picture tube mounting brackets to the mask.
5. Using the mounting brackets as hand holds, lift the picture tube assembly from the cabinet and place it face down on a protective pad.
6. Loosen both mounting strap bolts and lift the assembly from the picture tube.
7. Transfer the assembly to the new picture tube, orienting the straps so that the hole in the strap spring is aligned with the molded "U" on the picture tube. (See illustration of picture tube.)
8. Temporarily tighten the strap bolts so that the mounting brackets may be pressed tightly against the edge of the picture tube face plate. Hold the brackets in this position and finish tightening the strap bolts.
9. Lift picture tube assembly and install in cabinet. Install purity shield.
10. Reinstall chassis and all components.
11. After warm-up, follow complete degaussing, purity, convergence, and set-up procedure.

# OWNERS CONTROL PANEL-REAR VIEW CONFIGURATION

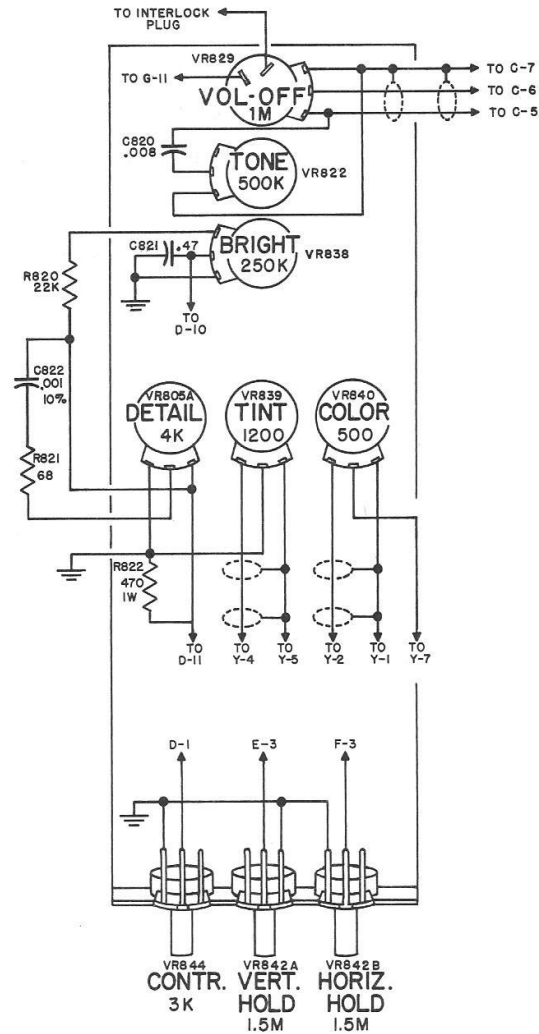

The BRIGHTNESS and CONTRAST controls can best be adjusted while viewing a black-and-white picture. Therefore, if colorcast is being transmitted during the initial tuning procedure, turn the COLOR control fully to the left.

Adjust BRIGHTNESS control to medium brightness on the screen; then adjust CONTRAST control for desired picture intensity. DETAIL control may then be adjusted for sharpness of picture. CONTRAST control will rarely need adjustment after first initial setting.

HORIZONTAL HOLD control is used to correct horizontal lines which may slant across the screen. Turn control to the left (counter-clockwise) and then

right slowly until picture appears normal. Turn slowly back until picture is straight and steady. If the setting of the horizontal hold control is not approximately in the center, adjust horizontal stabilizer control. (See CF-1 Unit alignment procedure).

VERTICAL HOLD control: If vertical movement of the picture exists, adjust control to stop up and down movement of the picture.

Rotate Channel Selector off and on station to check hold control settings. When Vertical and Horizontal hold controls are properly adjusted, picture will come to "lock-in" position from bottom (not from either side).

### REPLACEMENT PARTS

The items listed below are of specific design normally used in regular maintenance, and which we recommend for replacement.

Items not listed may be obtained by writing to our Parts Department, giving complete description of the required part, together with chassis and receiver models in which it is to be used. (Minimum order: \$1.00).

Prices subject to change without notice.

<b>Part No.</b>	<b>OWNER'S CONTROL PANEL</b>	
VR-805A	Detail control, 4000 ohm .....	\$1.40
VR-822	Tone control, 500 k. ....	1.40
VR-829	Volume control, 1 Meg. with switch .....	2.00
VR-838	Brightness control, 250 k. ....	1.40
VR-839	Tint control, 1200 ohm .....	1.40
VR-840	Color control, 500 ohm .....	1.40
VR-842	Horizontal hold control, 1.5 meg. ....	1.40
VR-842	Vertical hold control, 1.5 meg. ....	1.40
VR-844	Contrast control, 3000 ohm .....	1.40

**CHASSIS AND TUBE DIAGRAM - MODEL NO. U800**  
 SETCHELL-CARLSON INC. NEW BRIGHTON, ST. PAUL 12, MINN. U.S.A.

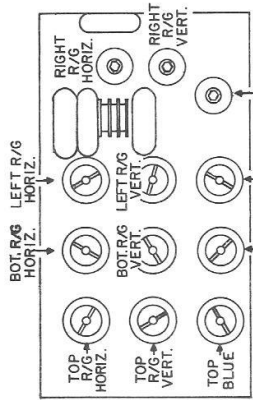
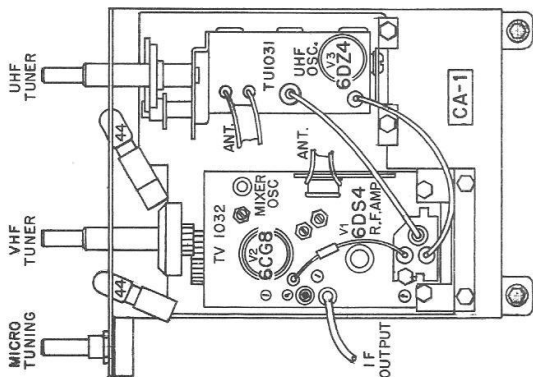

CONVERGENCE PANEL - ON INSIDE OF BAFFLE.  
 SEE SERVICE MANUAL FOR PROPER PROCEDURE  
 IN ADJUSTMENT OF THESE CONTROLS.

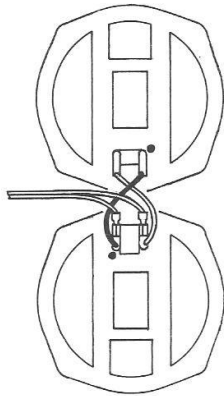

SPEAKER HOOKUP

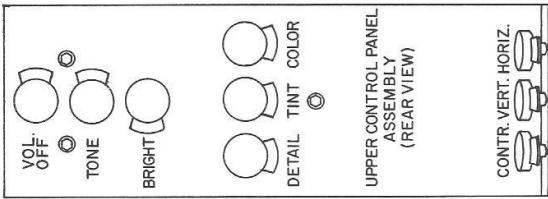

**\*IMPORTANT\*** FOLLOW ADJUSTMENT PROCEDURE AS  
 OUTLINED IN SERVICE MANUAL

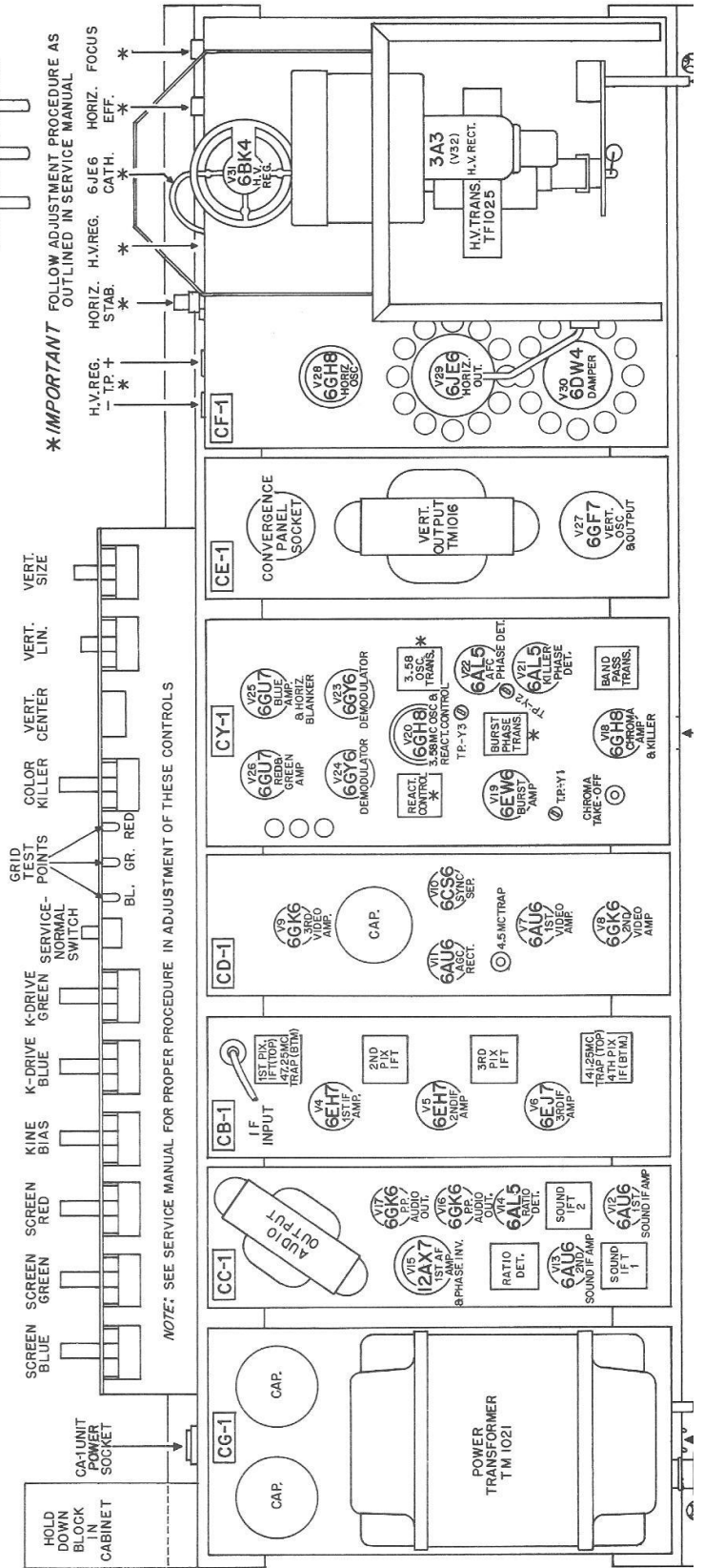

NOTE: SEE SERVICE MANUAL FOR PROPER PROCEDURE IN ADJUSTMENT OF THESE CONTROLS

ZR  
1035  
POWER  
RECTIFIER  
A.C. INTERLOCK  
POWER  
CIRCUIT  
BREAKER

PICTURE  
TUBE  
PROTECTOR  
(SEE SERVICE MANUAL)

HORIZ.  
CENTERING  
\*

#### REMOVAL OF CHASSIS:

1. Remove cabinet back. Open hinged service panel.
2. Remove front panel knobs and escutcheon plate. NOTE: If CA-1 Unit is to remain in the cabinet, it is not necessary to remove the escutcheon or the channel selector and micro tuning knobs.
3. Disconnect speaker output cable at speaker terminal board.
4. Disconnect CA-1 Unit power plug from front of chassis.
5. Disconnect shielded IF cable from CB-1 Unit.
6. Disconnect convergence plug from CE-1 Unit.
7. Disconnect the four deflection leads at the yoke terminals.
8. Disconnect focus anode lead from CF-1 Unit.
9. To avoid possible electrical shock, discharge picture tube by grounding HV anode terminal to chassis.
10. Disconnect picture tube socket and HV anode lead.
11. Disconnect ground clip from CF-1 Unit.
12. Remove three hex-head screws from rear of upper control panel. Control panel may now be lifted out and rested on the chassis.
13. Remove wood shipping block from above power transformer. This block need not be replaced unless the complete receiver is to be transported. Before shipping, however, be sure this block has been reinstalled.
14. Lift chassis up and back by grasping the power transformer and the vertical output transformer.
15. To remove CA-1 Unit, remove antenna terminal board from cabinet. Remove two hex-head screws from rear lips of Unit chassis. Slide Unit back and out.

## MAIN CHASSIS COMPONENTS - REAR VIEW CONFIGURATION

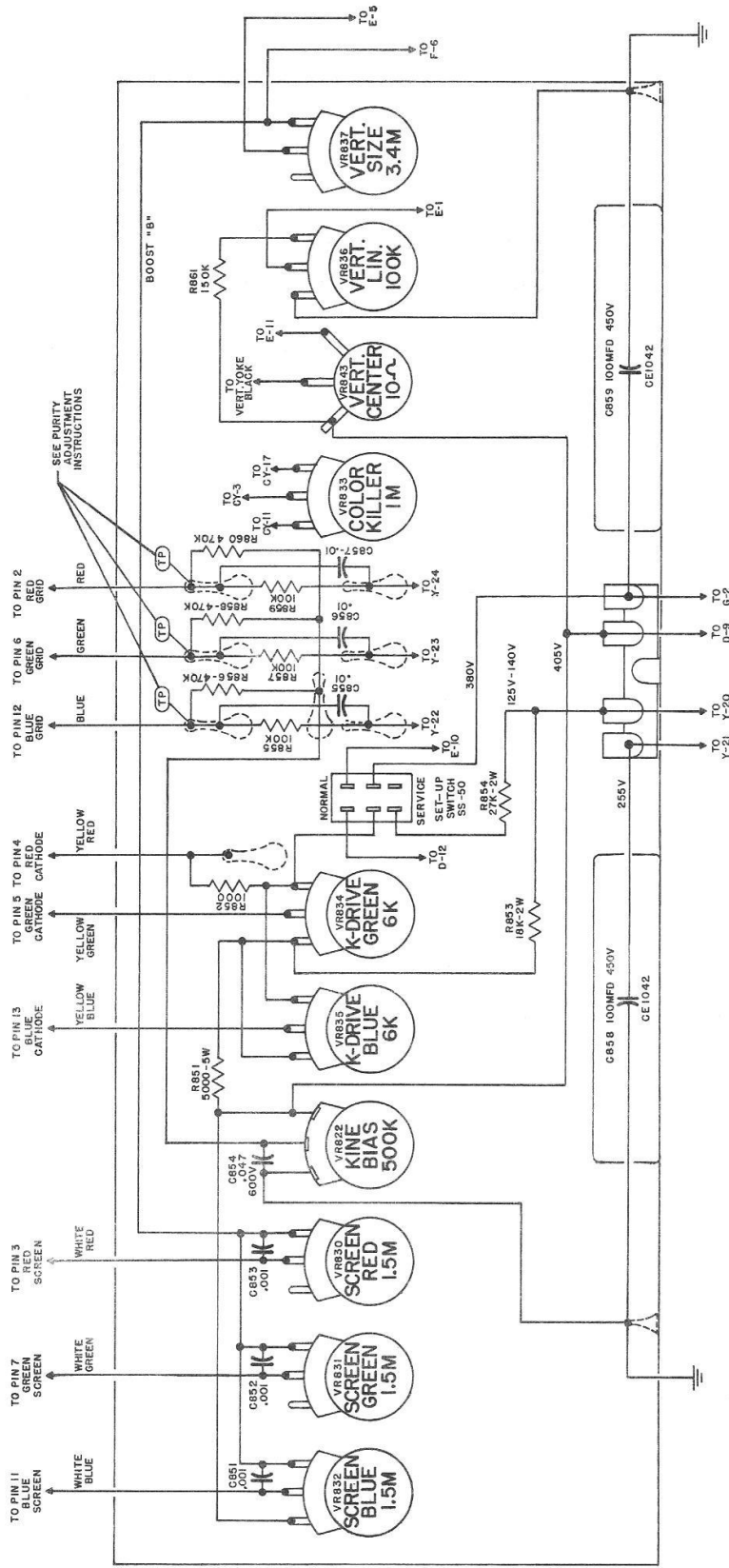

### COLOR TEMPERATURE ADJUSTMENTS:

1. Turn kine bias and red, green, and blue screen controls fully counter-clockwise. Turn green and blue cathode drive controls fully clockwise. Set "Service-Normal" switch in "Service position".
2. Advance red screen control fully clockwise, then retard the control approximately 20% from the maximum position. Advance the kine bias control until a red line is just visible.
3. Adjust the green and blue screen controls until the green and blue lines are also just visible. NOTE: The red gun is ordinarily the least sensitive of the three. Because of variations in tubes, however, the kine bias control should be adjusted to ignite the

weakest color with the screen control setting described for the red gun.

4. Return "Service-Normal" switch to "Normal" position.
5. Check black-and-white picture from highlights to lowlights at all normal brightness and contrast levels. If proper "tracking" is not obtained, alternately adjust green and blue cathode drive controls for best black-and-white picture.

### COLOR KILLER CONTROL:

Adjust with a snowy raster (no signal). Adjust Color Killer control so that color snow just disappears. Check with color signal to assure that setting is not killing on color.

## REPLACEMENT PARTS

The items listed below are of specific design normally used in regular maintenance, and which we recommend for replacement.

Items not listed may be obtained by writing to our Parts Department, giving complete description of the required part, together with chassis and receiver models in which it is to be used. (Minimum order: \$1.00).

Prices subject to change without notice.

### MAIN CHASSIS

VR-822	Kine bias control, 500 k. ....	\$1.40
VR-830	Screen control, red, 1.5 meg. ....	1.40
VR-831	Screen control, green, 1.5 meg. ....	1.40
VR-832	Screen control, blue, 1.5 meg. ....	1.40
VR-833	Color killer control, 1 meg. ....	1.40
VR-834	Cathode drive control, green, 6000 ohm ....	1.40
VR-835	Cathode drive control, blue, 6000 ohm ....	1.40
VR-836	Vertical linearity control, 100 k. ....	1.40
VR-837	Vertical size control, 3.4 Meg. ....	1.40
VR-843	Vertical centering control, 10 ohm. ....	1.40
SS-50	Service-normal switch ....	.50
CE-1042	100 mfd. 450 v. electrolytic capacitor ....	3.20
SO-1020	Picture tube socket and lead assembly ....	2.50

# DEGAUSSING, PURITY, AND STATIC CONVERGENCE

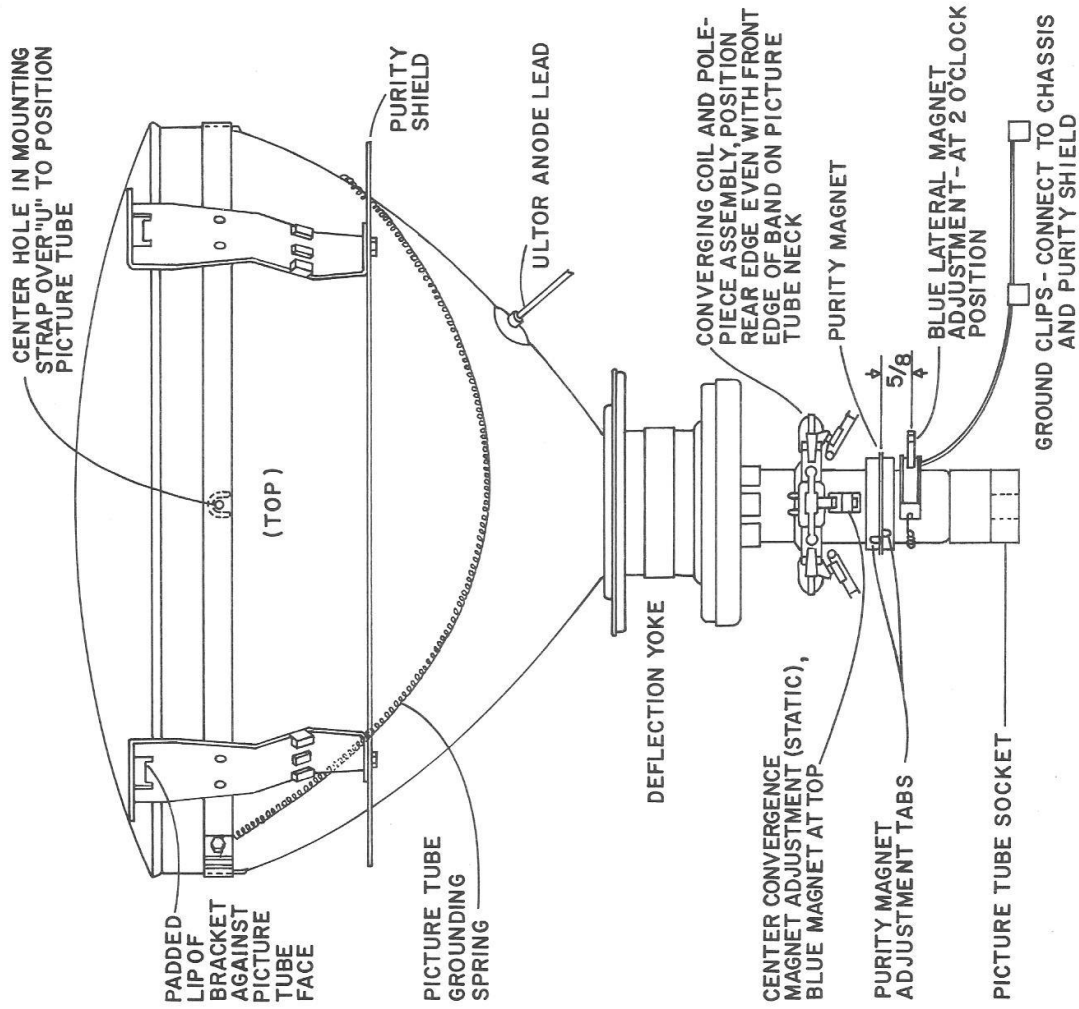

## DEGAUSSING AND PURITY ADJUSTMENTS:

1. Check adjustments of horizontal deflection circuitry, focus, height, linearity, and electrical centering.
2. Position the cabinet in its final location. Demagnetize the picture tube and chassis by slowly moving the degaussing coil around the picture tube face plate and the sides of the receiver. Withdraw the coil to a distance of at least six feet before disconnecting coil from the AC line.
3. Purity adjustments are most accurately made while observing one color only, preferably red. To do this, shunt the green and blue grid terminals to ground with jumper leads. The grid test points are easily reached through the front grill panel opening. Isolation resistors are incorporated in the receiver.
4. Loosen deflection yoke clamp, and move yoke back as far as possible without striking the convergence assembly.
5. Place the tabs of the purity magnet together. Spread them slowly, while rotating the ring assembly as a unit until the center of the red areas appears in the center of the screen.
6. Move yoke forward and adjust for best overall red raster with no neck shadow. Check purity of the green and blue fields by shunting out the other grids. If purity is not obtained in the green or blue fields, readjust the purity magnet and recheck all fields.



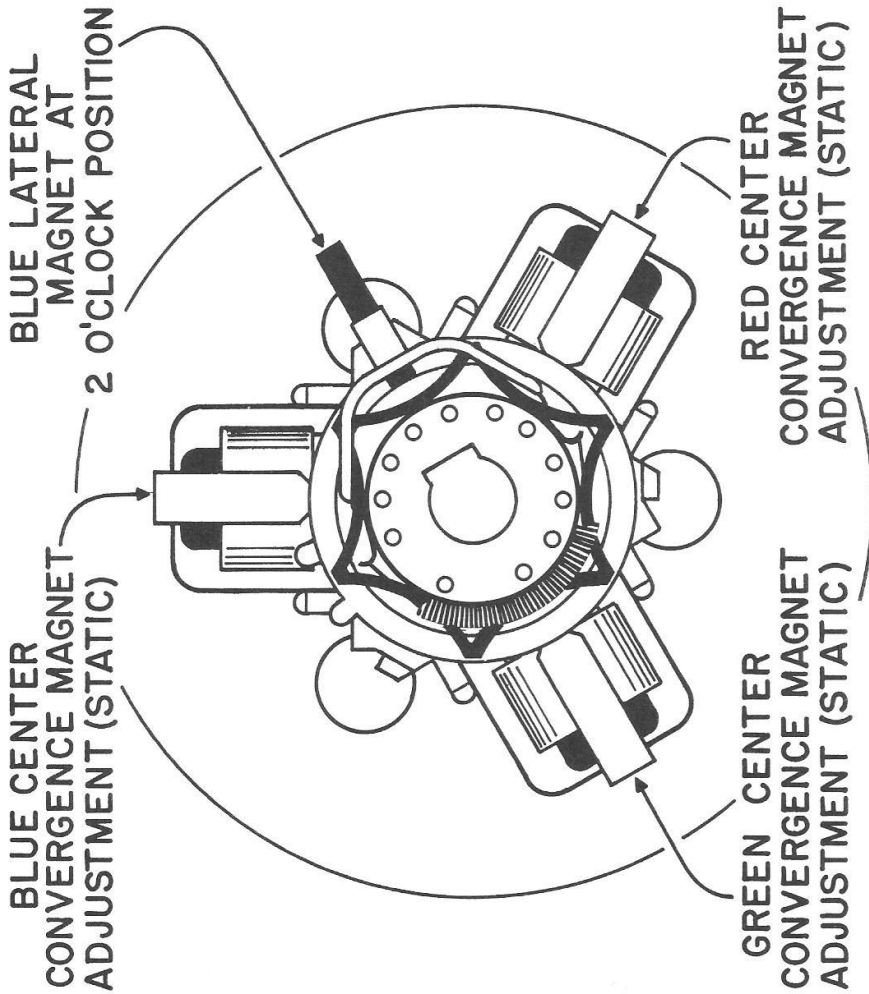

**TEST EQUIPMENT REQUIRED FOR CONVERGENCE:**  
 A cross-hatch pattern generator which produces white dots and narrow white vertical and horizontal lines is essential for proper convergence of this receiver. The generator must provide a stable RF output. Generator connection is made directly to the antenna input terminals. Test points are provided on the front of the receiver chassis so that individual grids may be shorted directly to ground without need for connection to the picture tube socket.

**STATIC CONVERGENCE ADJUSTMENTS**

1. Check horizontal osc., height, linearity, focus and centering.
2. Preset all horizontal & vertical convergence controls and coils to mid-range.
3. Adjust red, green and blue magnets and lateral magnet to produce a white dot in the center of the screen.

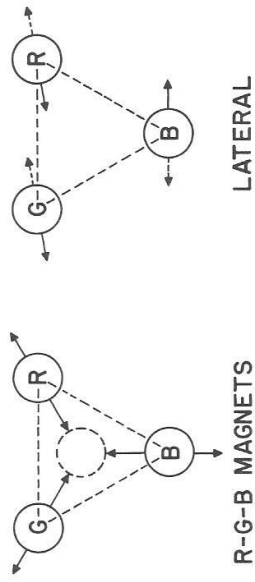

**DOT MOVEMENT PATTERN**

4. Keep receiver in focus when making adjustments.

---

### REPLACEMENT PARTS

The items listed below are of specific design normally used in regular maintenance, and which we recommend for replacement.

Items not listed may be obtained by writing to our Parts Department, giving complete description of the required part, together with chassis and receiver models in which it is to be used. (Minimum order: \$1.00).

Prices subject to change without notice.

Y-1023	Deflection Yoke .....	\$38.50
Z-1024	Dynamic convergence assembly (magnet assembly wired to complete convergence control panel) .....	*
Z-1022	Purity ring magnet assembly .....	1.50
Z-1014	Blue lateral magnet assembly .....	.75

\* See unit price list.

### CONVERGENCE ASSEMBLY

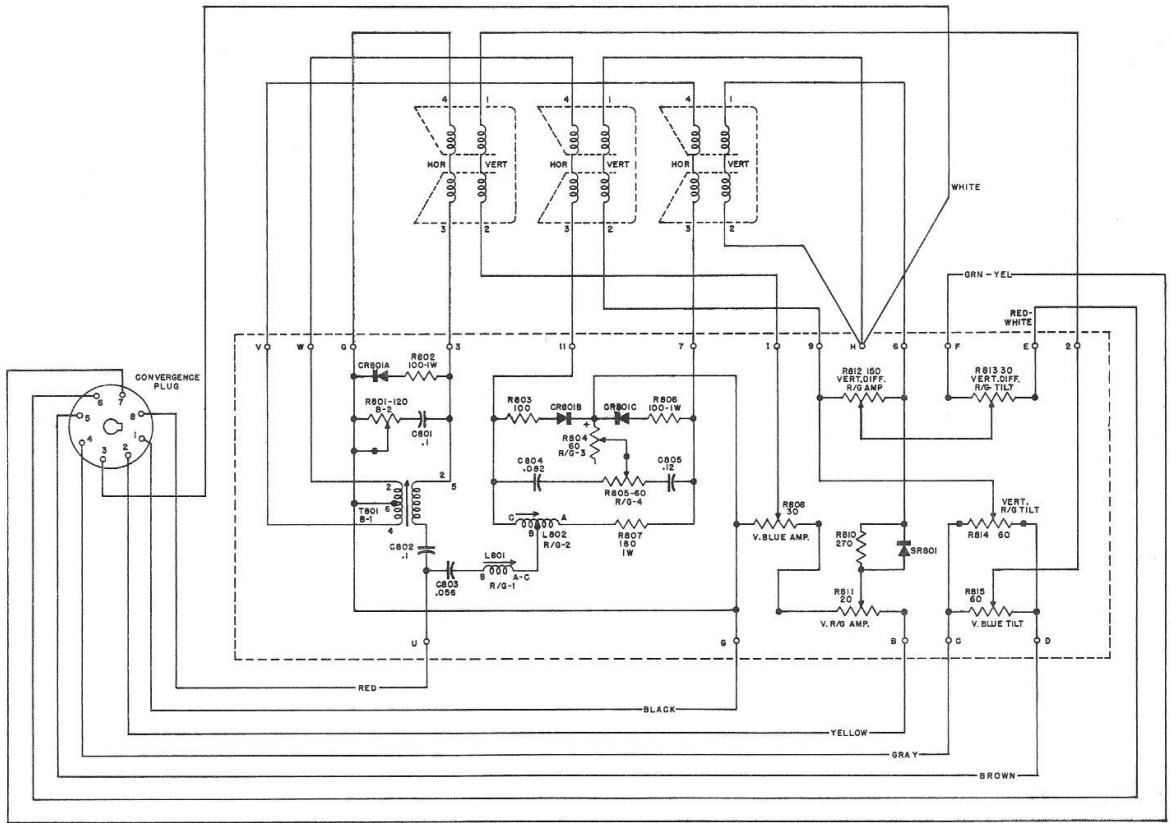

### DEFLECTION YOKE

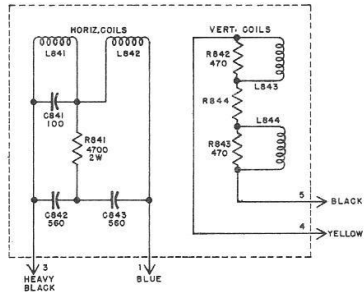

## VERTICAL CONVERGENCE ADJUSTMENTS

1.
  - (a) Preset all H and V convergence controls to midrange.
  - (b) Adjust magnets to produce white dots in center of screen (static)
  - (c) Short out blue gun.

2.

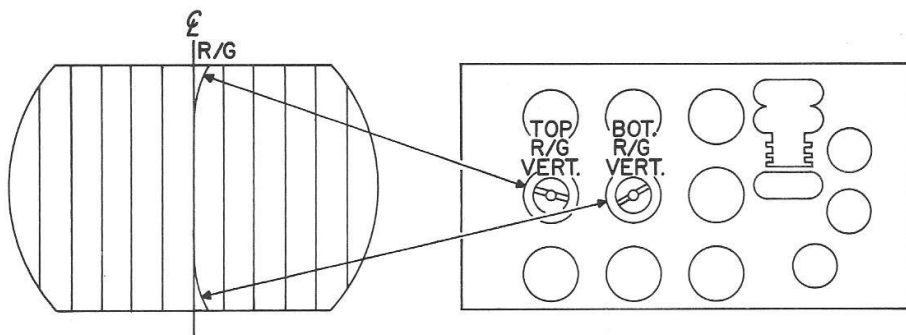

- (a) Converge center bar at bottom.
- (b) Converge center bar at top.
- (c) Touch up both for best convergence along entire center line.

3.

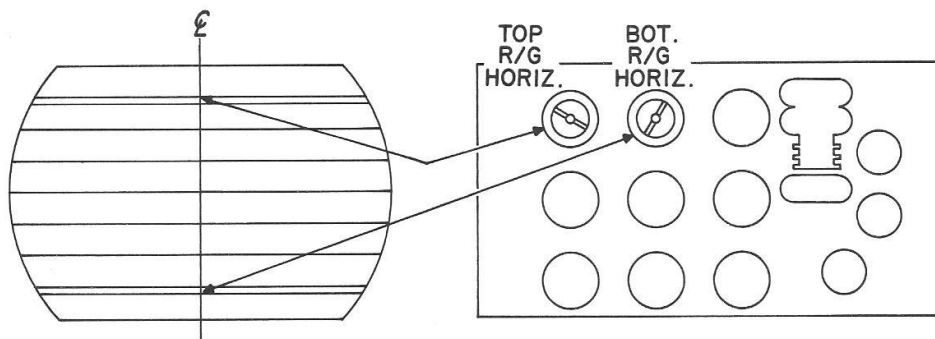

- (a) Converge bottom horizontal bar at center line.
- (b) Converge top horizontal bar at center line.
- (c) Touch up both for best convergence of all bars at center line.
- (d) Center converge (static)
- (e) Remove blue gun jumper.

4.

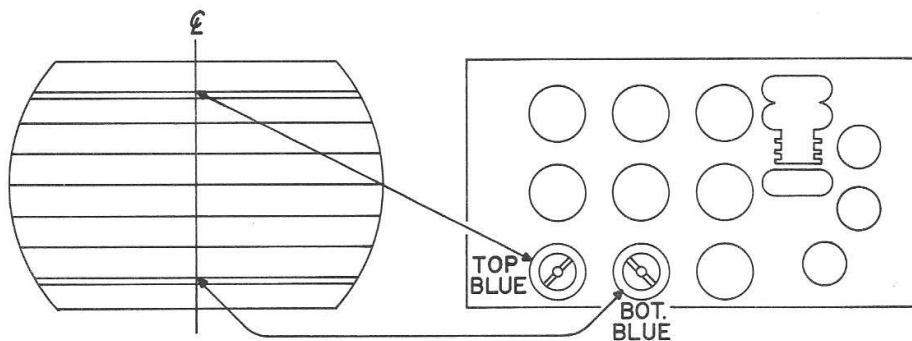

- (a) Displacement of blue bar top & bottom at C/L.
- (b) Equal displacement top & bottom at C/L.
- (c) Adjust both for equal displacement of all bars at C/L from top to bottom.
- (d) Center converge (static).
- (e) Retouch both controls for best convergence along C/L.

### HORIZONTAL COVERAGE ADJUSTMENTS

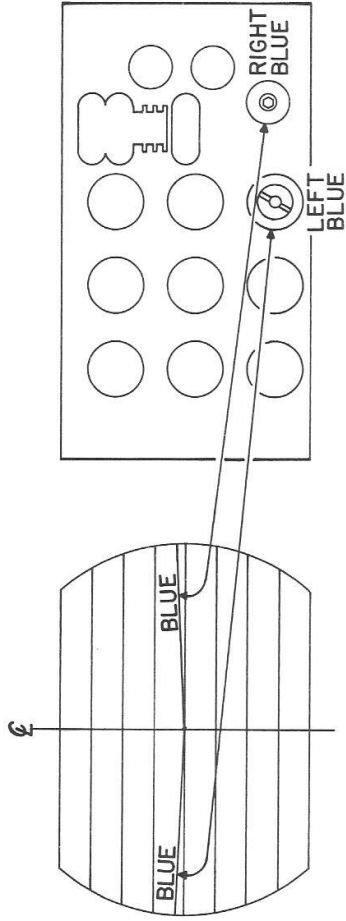

- (a) Adjust to make blue line a straight line at right of center.
- (b) Adjust to make blue line a straight line at left of center.

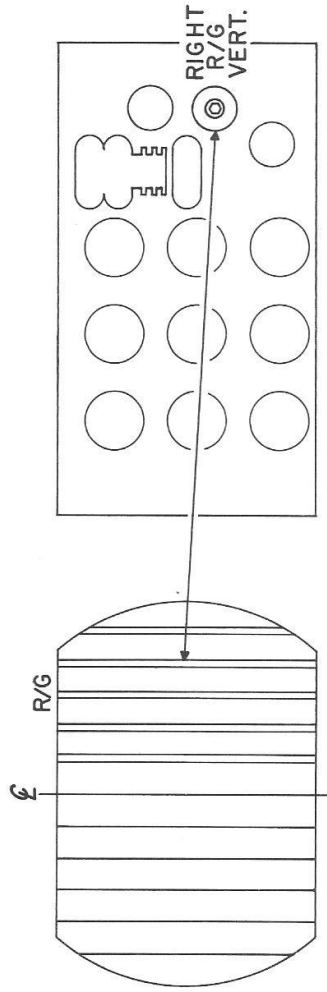

Converge vertical lines on right side.

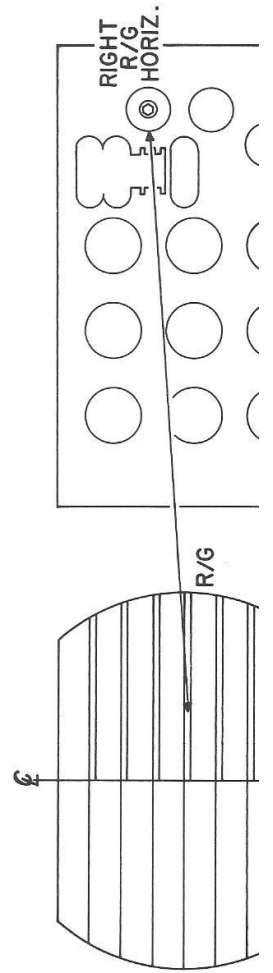

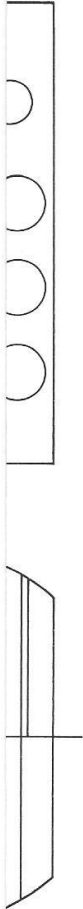

- (a) Converge horizontal red & green lines on right side.
- (b) Readjust to make blue line at right center converge with red and green.
- (c) Retouch for convergence of vertical lines on right side.

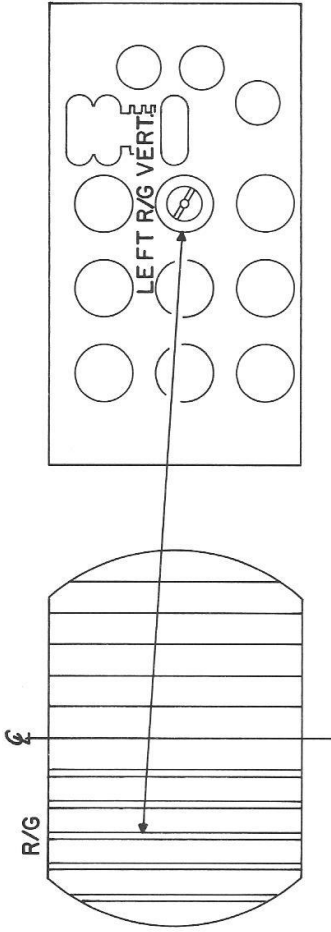

Converge vertical lines at left side of center.

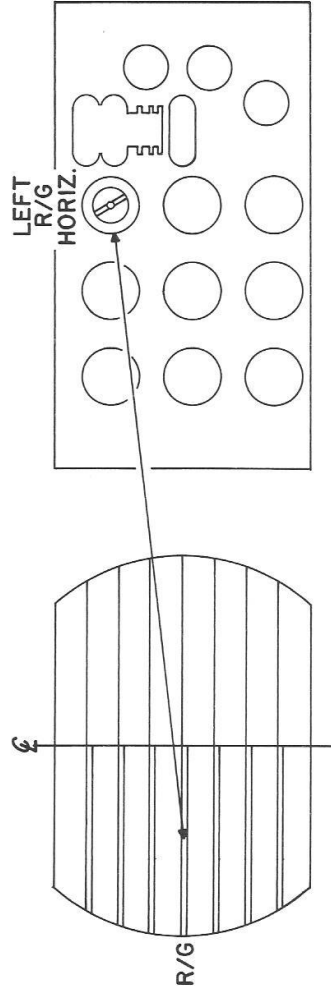

- (a) Converge red and green lines at left side of center.
- (b) Repeat to converge vertical lines at left side of center.
- (c) Readjust to make blue line at left center a straight line and converge with red and green.

VHF TUNER ASSEMBLY - UNIT NO. CA-1  
UHF-VHF TUNER ASSEMBLY - UNIT NO. CA-1U

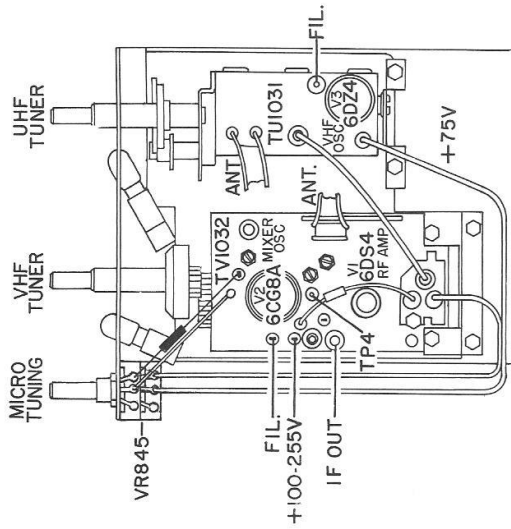

VIDEO IF ALIGNMENT PROCEDURE: UNITS CA-1 AND CB-1

TEST EQUIPMENT: VIDEO IF SWEEP GENERATOR; MARKER GENERATOR (IF MARKERS ARE NOT CONTAINED IN SWEEP GENERATOR); OSCILLOSCOPE; BIAS SUPPLY. SWEEP GENERATOR MUST BE PROPERLY TERMINATED IN ACCORDANCE WITH EQUIPMENT MANUFACTURER'S INSTRUCTIONS.

1. DISABLE HORIZONTAL SWEEP BY REMOVING 6AY3 DAMPER TUBE. DISCONNECT SHIELDED TUNER OUTPUT CABLE FROM UNIT CB-1. APPLY 8 VOLT NEGATIVE BIAS TO TERMINAL CB-4. CONNECT OSCILLOSCOPE, THROUGH A 10,000 OHM RESISTOR, TO TERMINAL CB-12.
2. CONNECT TERMINATED OUTPUT OF SWEEP GENERATOR, THROUGH A .001 MFD CERAMIC CAPACITOR, TO TP-1. IN THIS AND EACH OF THE FOLLOWING STEPS, THE GENERATOR AND TUNER MUST BE ADJUSTED TO MAINTAIN A PATTERN AMPLITUDE OF 1.5 VOLTS (PEAK TO PEAK) ON THE OSCILLOSCOPE.
3. ADJUST BOTTOM CORE AND TOP CORE (41.25 MC TRAP) OF T-104 TO OBTAIN THE RESPONSE CURVE SHOWN IN FIG. 1. MARKER FREQUENCIES ARE INDICATED ON THE CURVE. ADJUST VR-102 FOR MAXIMUM 41.25 MC TRAP ATTENUATION. RE-CHECK T-104.
4. CONNECT SWEEP GENERATOR, THROUGH A .001 MFD CAPACITOR, TO TP-2. ADJUST THE TOP AND BOTTOM CORES OF T-103 TO OBTAIN THE CURVE SHOWN IN FIG. 2.
5. CONNECT SWEEP GENERATOR THROUGH CAPACITOR, TO TP-3. ADJUST TOP AND BOTTOM CORES OF T-102 TO OBTAIN THE CURVE SHOWN IN FIG. 3.
6. CONNECT SHIELDED TUNER OUTPUT CABLE TO UNIT CB-1. CONNECT SWEEP GENERATOR TO TP-4 (VHF TUNER MIXER GRID), TURN CHANNEL SELECTOR TO CHANNEL 13. ADJUST L-8 (ON TUNER), TOP CORE OF T-101, AND BOTTOM CORE OF T-101 (47.25 MC TRAP) TO OBTAIN THE RESPONSE CURVE SHOWN IN FIG. 4. ADJUST VR-101 FOR MAXIMUM 47.25 MC ATTENUATION. RECHECK CORE ADJUSTMENTS OF T-101.
7. TO CHECK OUTPUT LEVEL OF SOUND DETECTOR, CONNECT OSCILLOSCOPE TO TERMINAL CB-11. RECONNECT SIGNAL GENERATOR TO TP-1. THE RESPONSE CURVE SHOULD APPROXIMATE FIG. 5.

\* VOLTAGES SHOWN FOR THIS UNIT MEASURED WITH ZERO SIGNAL INPUT. VOLTAGE VARIES WITH SIGNAL STRENGTH.

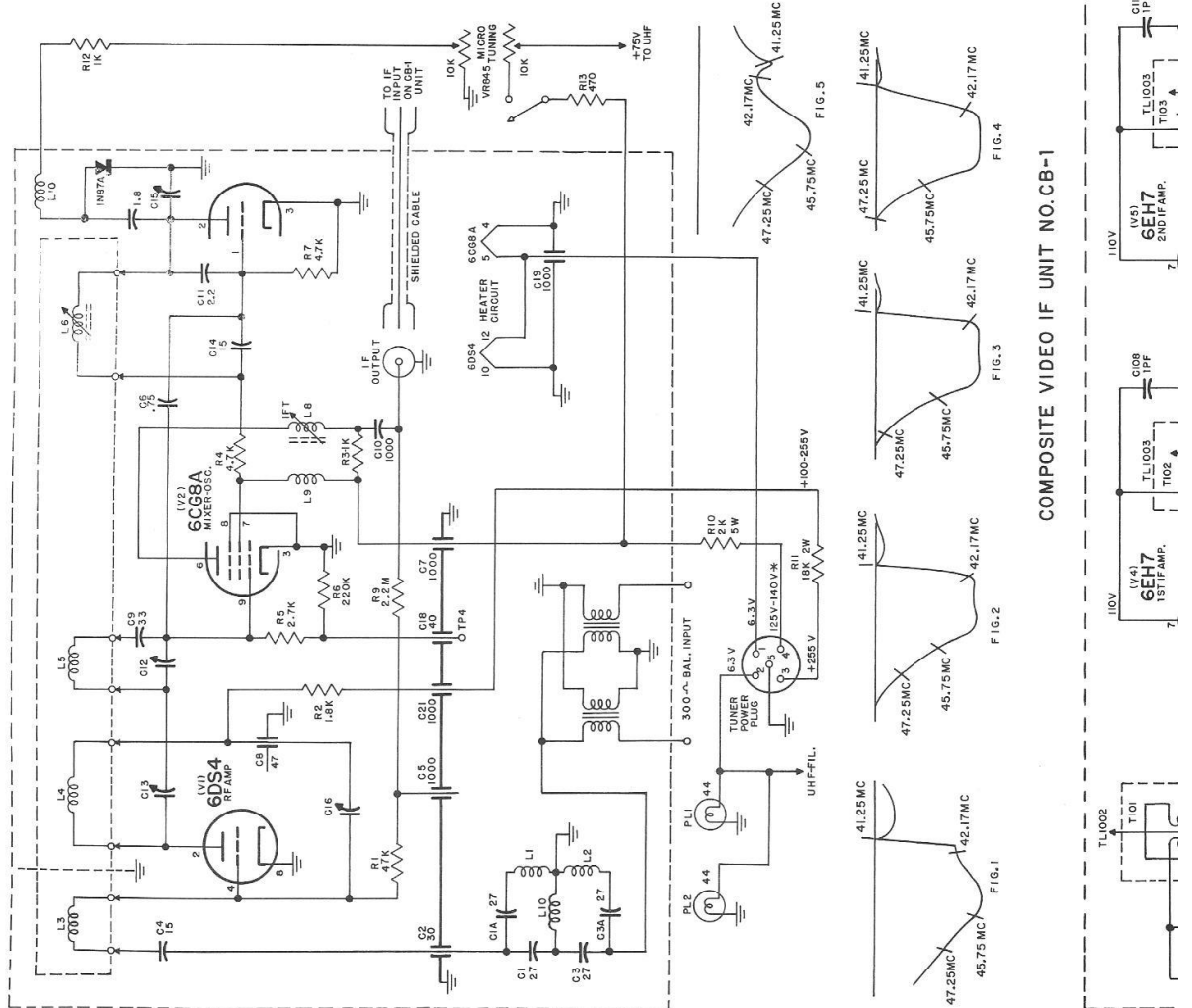

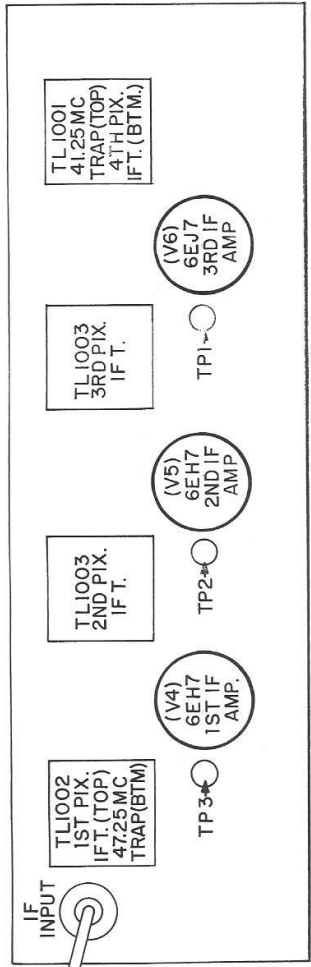
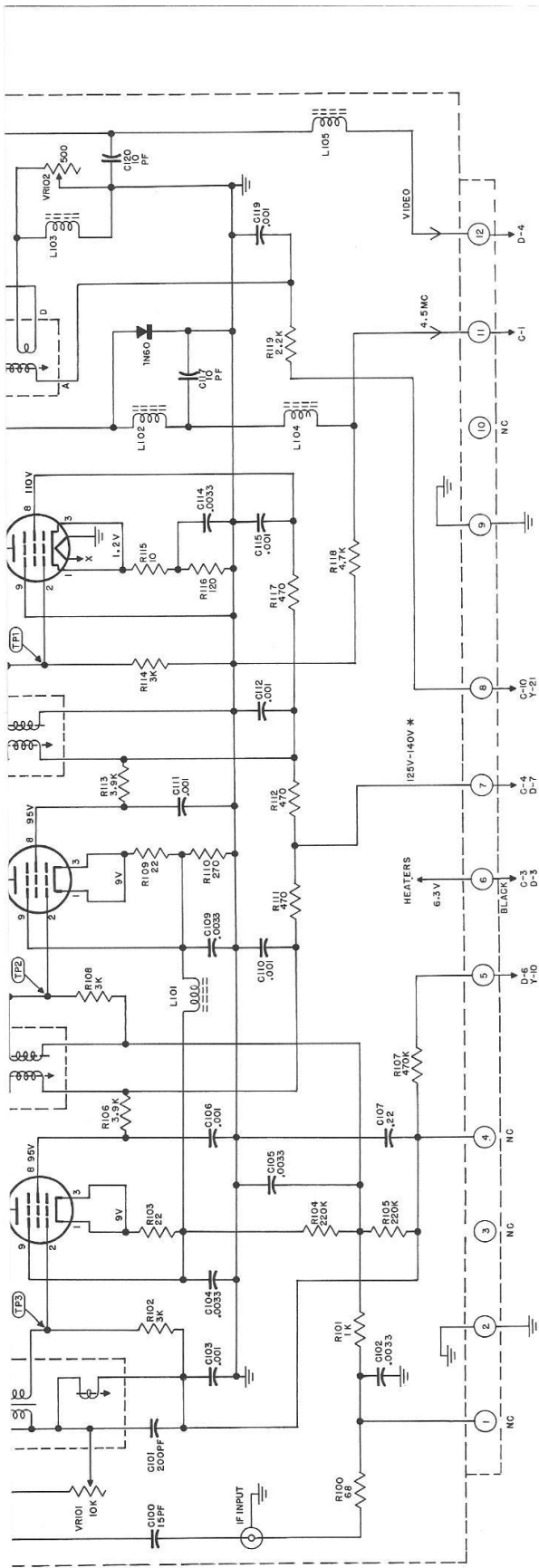



## REPLACEMENT PARTS

The items listed below are of specific design normally used in regular maintenance, and which we recommend for replacement.

Items not listed may be obtained by writing to our Parts Department, giving complete description of the required part, together with chassis and receiver models in which it is to be used. (Minimum order: \$1.00).

Prices subject to change without notice.

<b>Part No.</b>	<b>UNIT CA-I &amp; CA-IU</b>	
TV-1032	VHF Color Tuner .....	*
VR-805A	4000 ohm control, microtuning .....	\$1.40
U-62-1	UHF Tuner .....	*
VR-845	Dual 10,000 ohm control, VHF-UHF microtuning .....	\$3.50
ZW-1030	28" IF output cable .....	1.40
	* See unit price list.	
	<b>UNIT CB-I</b>	
TL-1001	Output IF transformer and 41.25 MC trap .....	\$3.50
TL-1002	Input IF transformer and 47.25 MC trap .....	2.00
TL-1003	Interstage IF transformer .....	1.70
RV-1043	10 k. miniature variable resistor, 47.25 MC trap adjust. ....	1.00
RV-1044	500 ohm miniature variable resistor, 41.25 MC trap adjust. ....	1.00
LC-106	12 microhenry rf choke .....	.50

4.5MC AND SOUND UNIT NO.CC-1

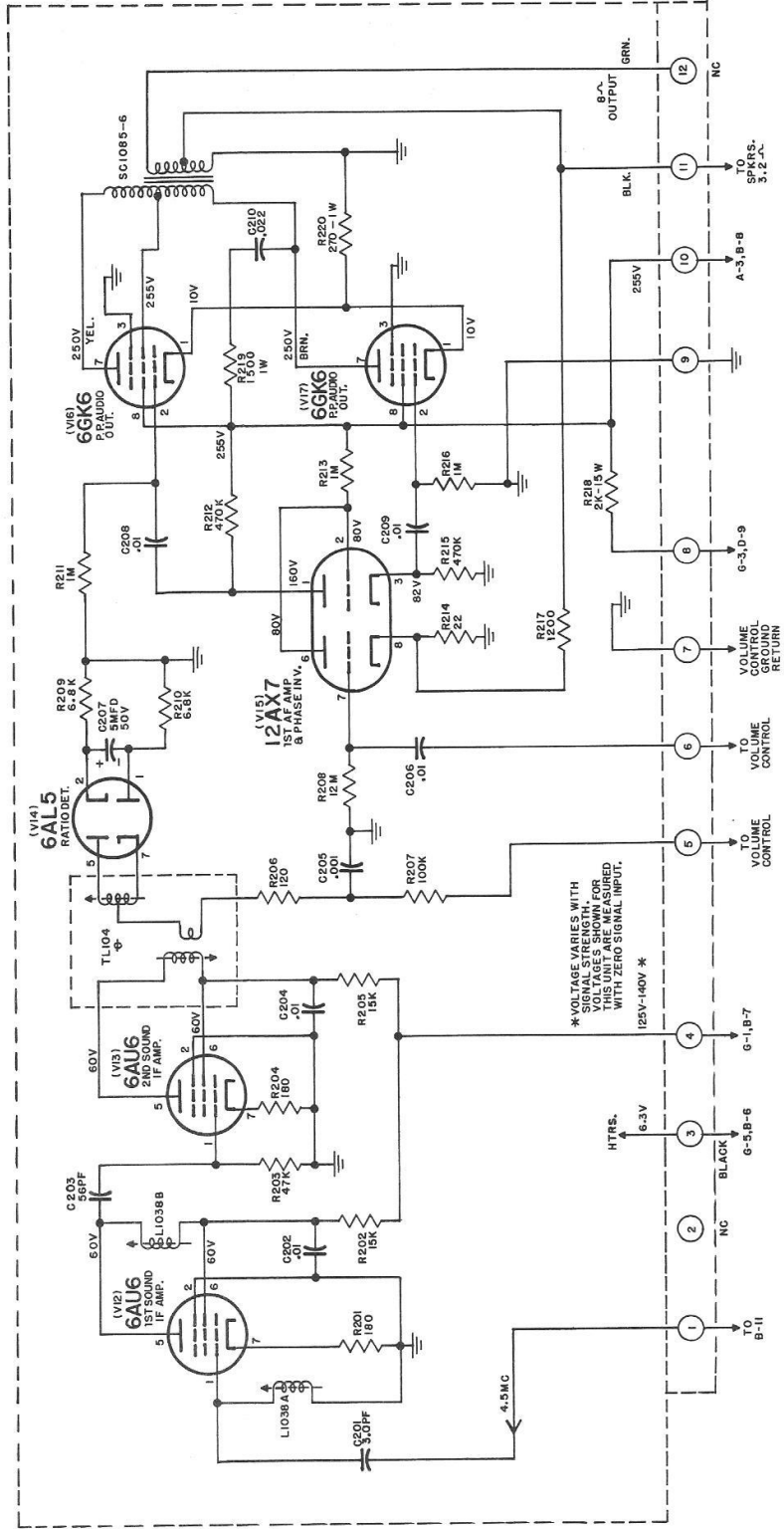

Φ TL104 SECONDARY (TOP CORE) MAY BE ADJUSTED ON STATION TO COMPENSATE FOR MINIMUM NOISE OR SYNC BUZZ.

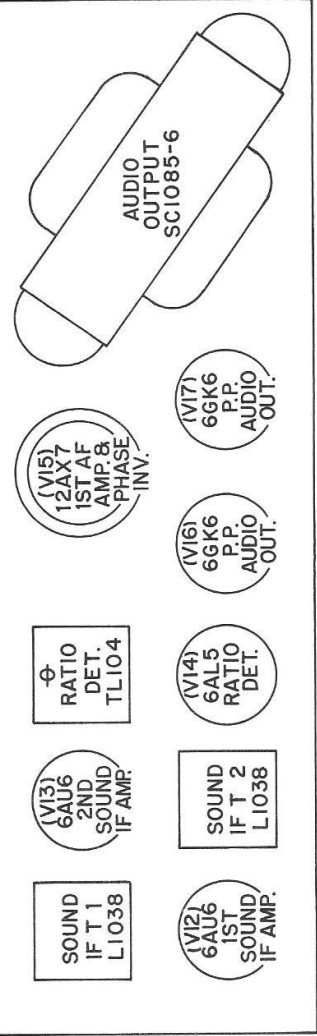

### REPLACEMENT PARTS

The items listed below are of specific design normally used in regular maintenance, and which we recommend for replacement.

Items not listed may be obtained by writing to our Parts Department, giving complete description of the required part, together with chassis and receiver models in which it is to be used. (Minimum order: \$1.00).

Prices subject to change without notice.

#### UNIT CC-1

L-1038	4.5 MC sound take-off & interstage coil .....	\$ .60
TL-104	4.5 MC ratio detector transformer .....	2.75
SC1085-6	Audio output transformer .....	5.00

SYNC, AGC AND VIDEO AMPLIFIER UNIT NO. CD-1

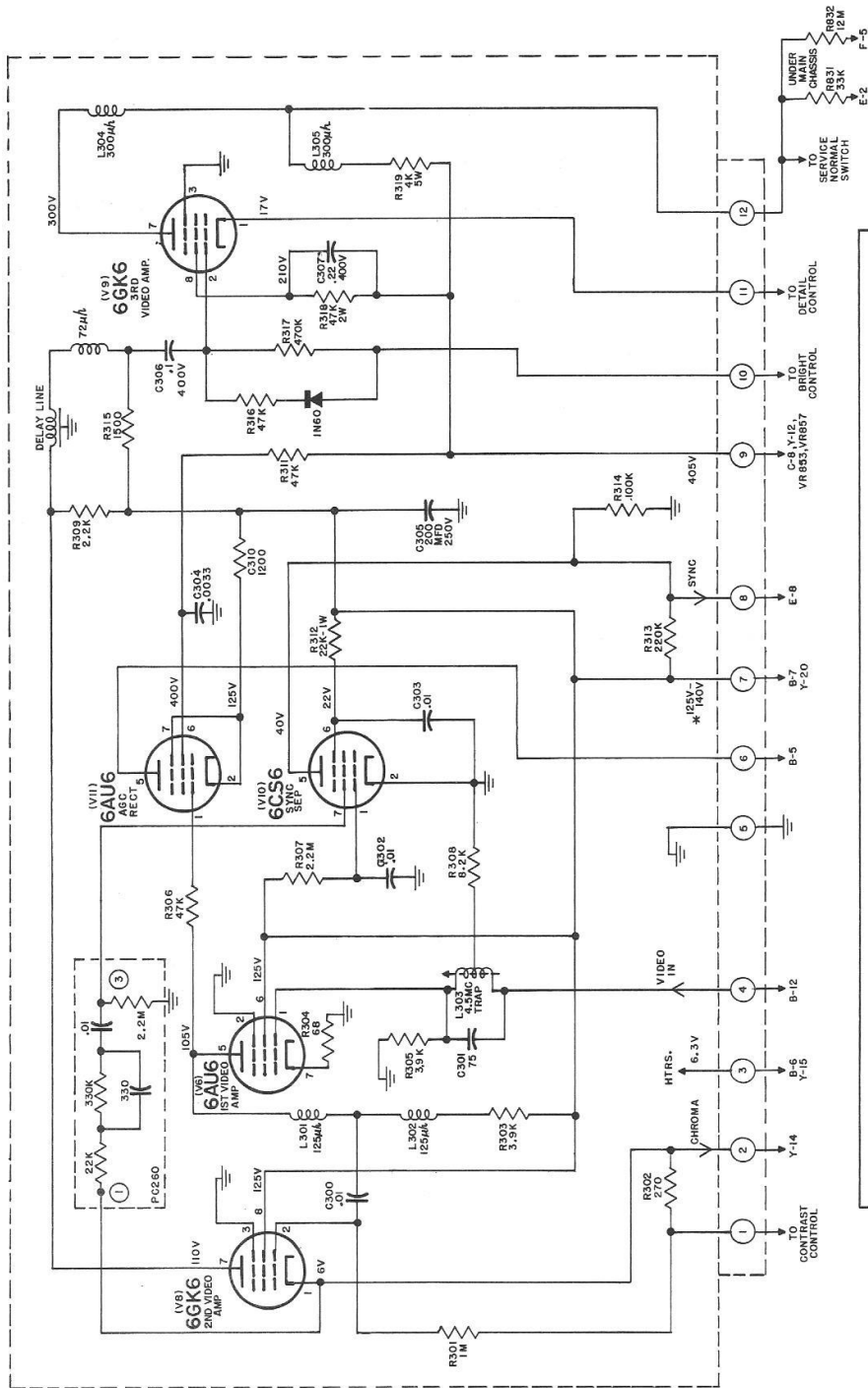

\* VOLTAGE VARIES WITH SIGNAL STRENGTH. VOLTAGES SHOWN FOR THIS UNIT ARE WITH ZERO SIGNAL INPUT.

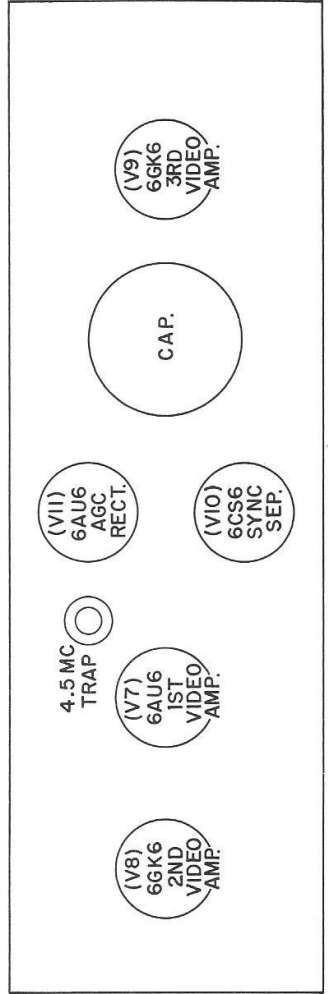

### REPLACEMENT PARTS

The items listed below are of specific design normally used in regular maintenance, and which we recommend for replacement.

Items not listed may be obtained by writing to our Parts Department, giving complete description of the required part, together with chassis and receiver models in which it is to be used. (Minimum order: \$1.00).

Prices subject to change without notice.

#### UNIT CD-1

TL-1004	4.5 MC trap coil.....	\$1.65
L-1005	73 microhenry choke coil.....	.50
L-1036	125 microhenry peaking coil.....	.50
LC-102	300 microhenry peaking coil (blue).....	.50
PC-260	PC-260 couplate.....	1.00
DL-1017	Delay line.....	2.00
CE-1039	200 mfd. 250 v. electrolytic capacitor, twistlock can.....	3.00

VERTICAL DEFLECTION UNIT NO.CE - 1

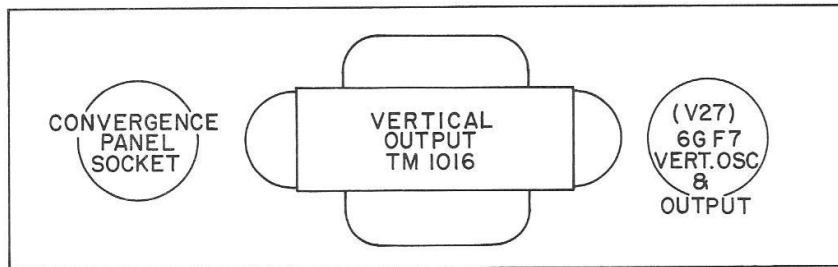
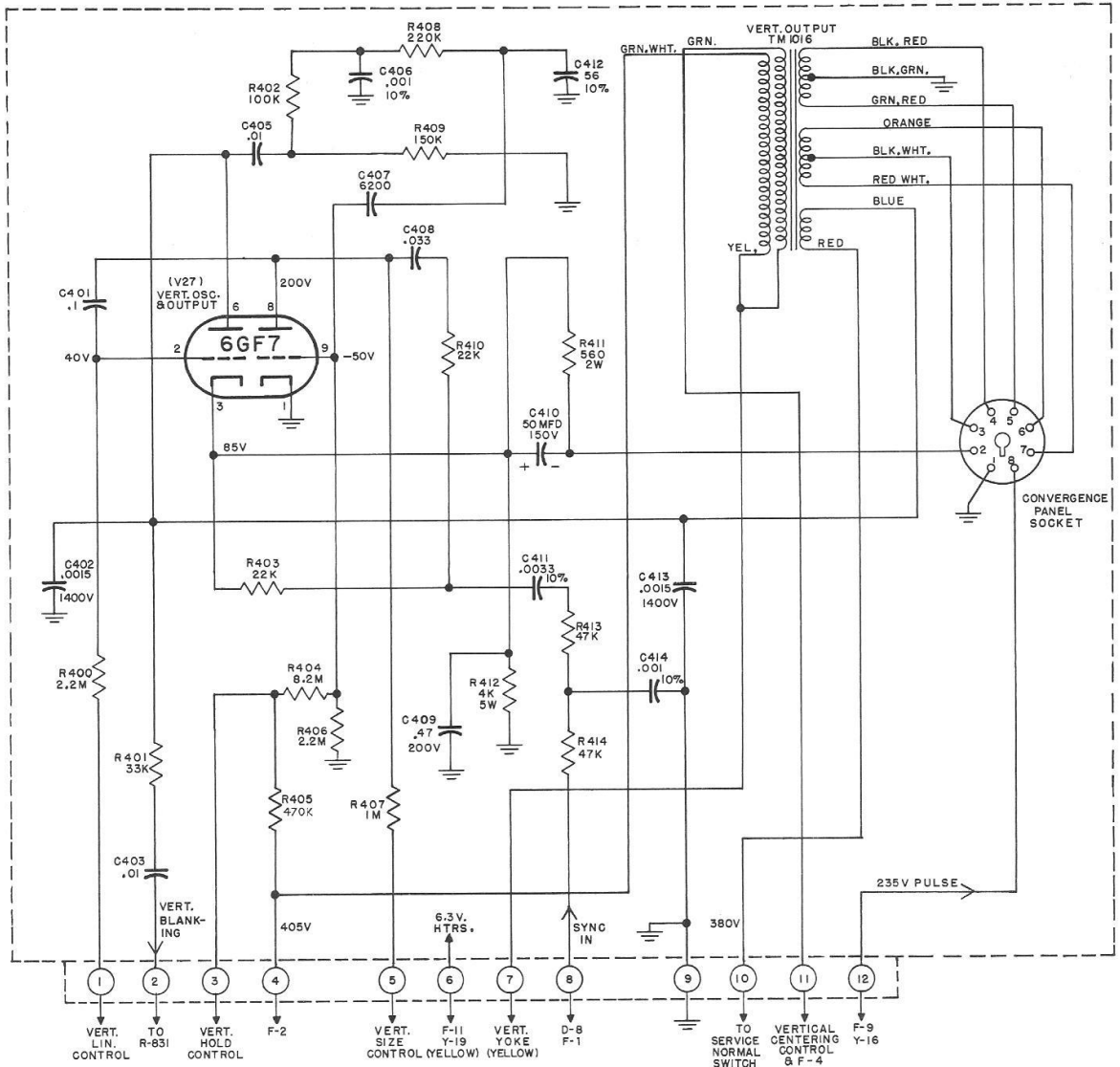

**REPLACEMENT PARTS**

The items listed below are of specific design normally used in regular maintenance, and which we recommend for replacement.

Items not listed may be obtained by writing to our Parts Department, giving complete description of the required part, together with chassis and receiver models in which it is to be used. (Minimum order: \$1.00).

Prices subject to change without notice.

**UNIT CE-1**

TM-1016 Vertical Output Transformer ..... \$6.00

HORIZONTAL, HIGH VOLTAGE AND REGULATOR UNIT NO. CF-1

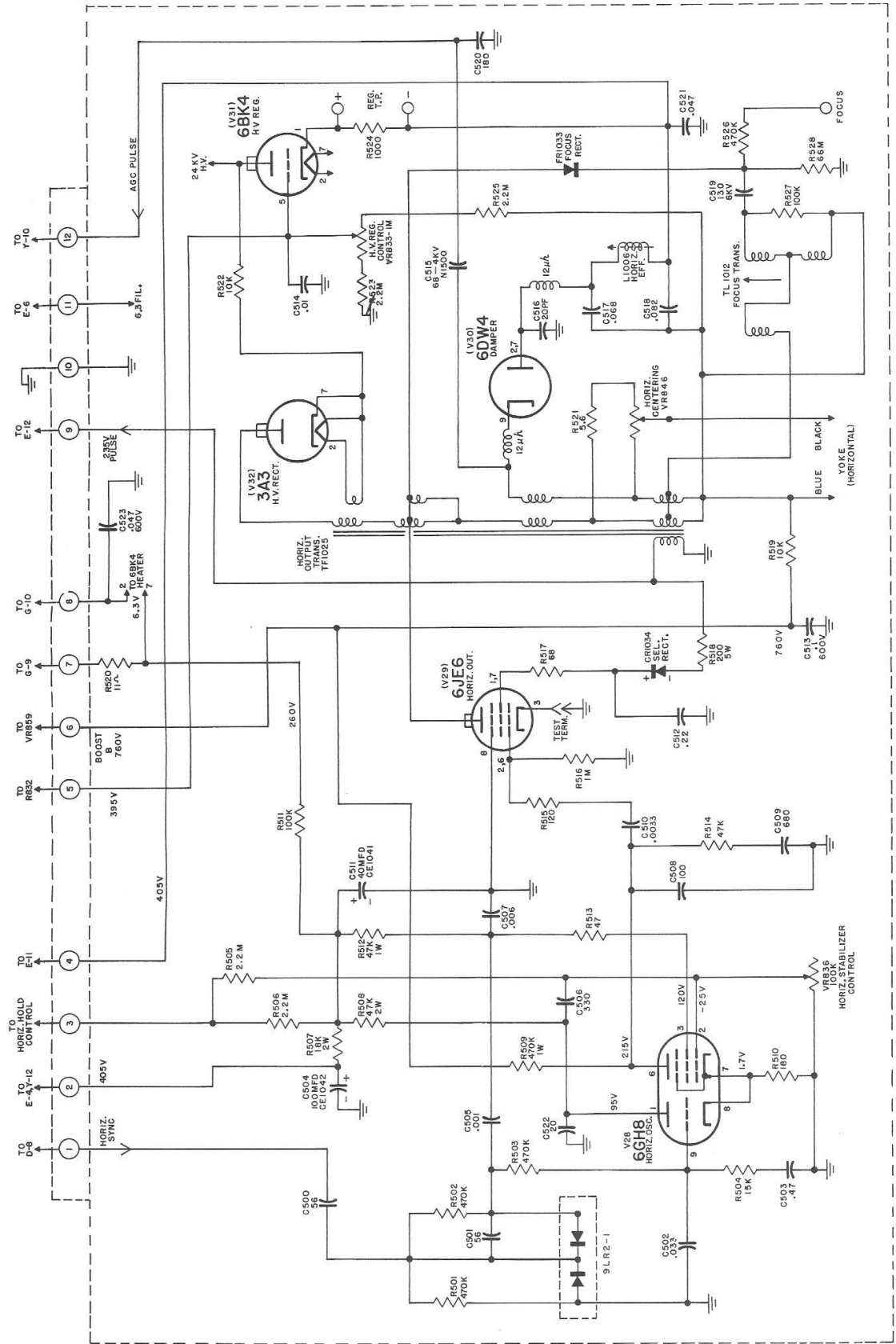



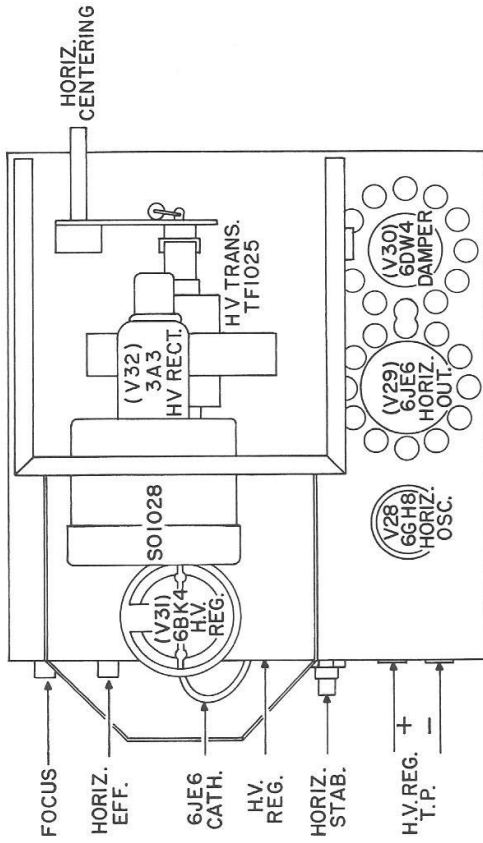

**CF-1 UNIT ALIGNMENT:**

**HORIZONTAL STABILIZER CONTROL:**

Adjust horizontal hold control on front panel to mid-range position.  
Adjust horizontal stabilizer control for best horizontal lock-in.

**HORIZONTAL EFFICIENCY CONTROL:**

A quick-disconnect terminal is provided on the front of the CF-1 Unit for measurement of the 6JE6 cathode current. Connect a milliammeter in series, and adjust the horizontal efficiency control for minimum cathode current. Current reading should not exceed 225 milliamperes.

**H.V. REGULATOR CONTROL:**

Insert test prods of voltmeter (approximately 0-3 v. range, 20,000 ohms-per-volt) through the grommets to make contact with the test points provided on the front of the CF-1 Unit. Turn brightness and kine bias controls to minimum position. Adjust HV Regulator control for a dc reading of 1 volt across the test points. At this reading, test points are above ground potential. Avoid accidental grounding of meter, and do not attempt the adjustment with a VTVM having a direct connection to the case.

**FOCUS CONTROL:**

Adjust core of focus transformer for best focus on normal picture.

## REPLACEMENT PARTS

The items listed below are of specific design normally used in regular maintenance, and which we recommend for replacement.

Items not listed may be obtained by writing to our Parts Department, giving complete description of the required part, together with chassis and receiver models in which it is to be used. (Minimum order: \$1.00).

Prices subject to change without notice.

### UNIT CF-1

TL-1012	Focus Transformer .....	\$2.00
L-1006	Horizontal Efficiency Coil.....	1.25
TF-1025	Horizontal Output Transformer .....	17.50
LC-106	12 microhenry rf choke coil.....	.50
FR-1033	Focus rectifier.....	6.00
CR-1034	Screen Control Rectifier .....	1.75
Z-1015	Vented 6BK4 cap and lead assembly.....	1.50
SO-1028	3A3 rectifier socket .....	1.50
SO-1029	Plastic cap for 3A3 socket .....	.25
CE-1041	40 mfd. 450 v. electrolytic capacitor.....	1.80
CE-1042	100 mfd. 450 v. electrolytic capacitor.....	3.20
VR-846	Horizontal centering control, 10 ohm.....	1.40
VR-833	H.V. Regulator control, 1 Meg. ....	1.40
VR-836	Horizontal stabilizer control, 100 k. ....	1.40

# MAIN POWER SUPPLY UNIT NO. CG-1

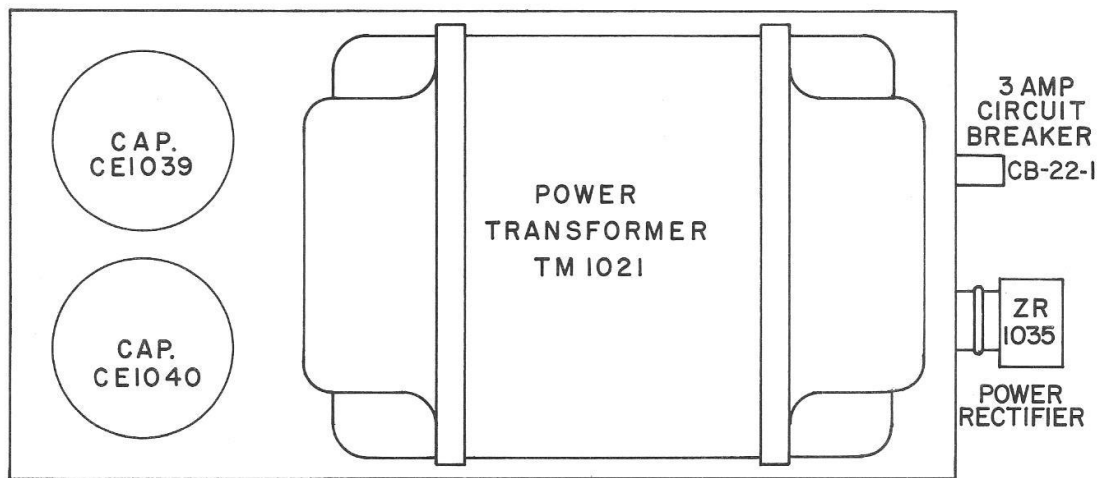
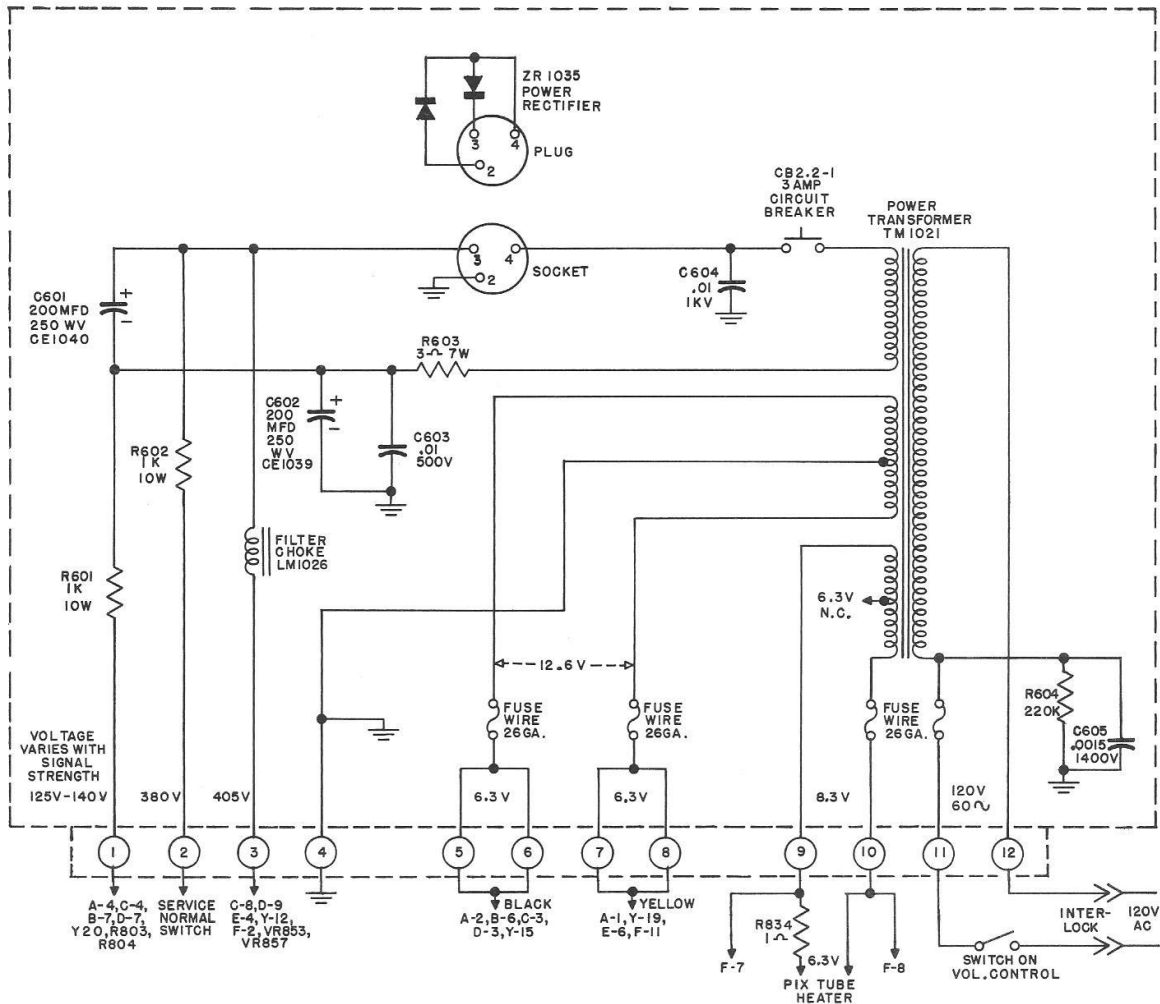

### REPLACEMENT PARTS

The items listed below are of specific design normally used in regular maintenance, and which we recommend for replacement.

Items not listed may be obtained by writing to our Parts Department, giving complete description of the required part, together with chassis and receiver models in which it is to be used. (Minimum order: \$1.00).

Prices subject to change without notice.

#### UNIT CG-1

TM-1021	Power Transformer .....	\$35.00
LM-1026	Filter choke .....	2.75
CB-22-1	Circuit breaker .....	1.30
CE-1039	200 mfd. 250 v. electrolytic capacitor .....	3.00
CE-1040	200 mfd. 250 v. electrolytic capacitor, with insulating sleeve .....	3.20
ZR-1035	Dual silicon rectifier assembly, 1 amp., 600 prv. ....	5.00

CHROMA UNIT NO. CY-1

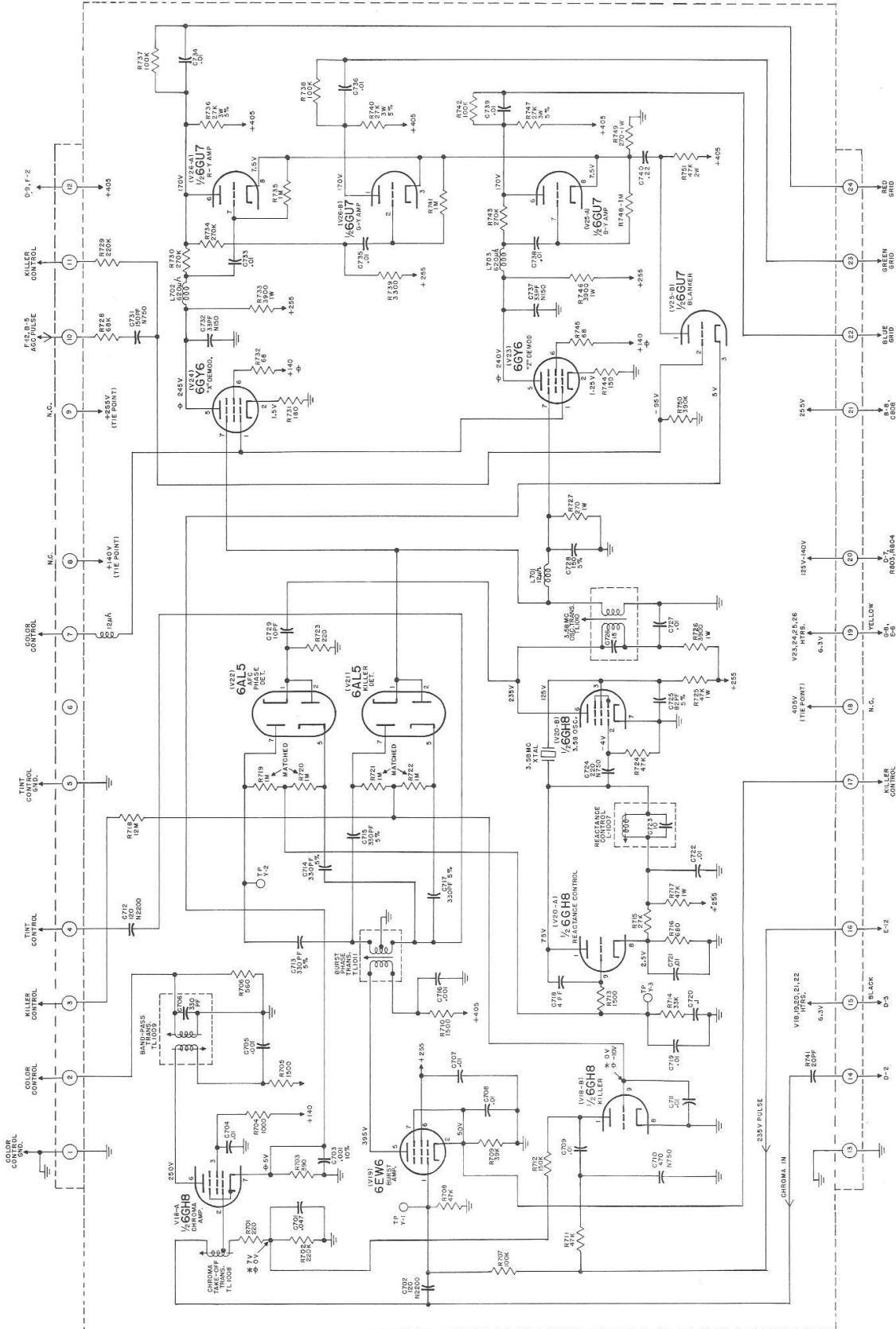

\* VOLTAGE READ WITH ZERO SIGNAL  
 † VOLTAGE READ WITH STRONG COLOR SIGNAL

TP-Y1

I 100R

3.0 MC 4.0 MC

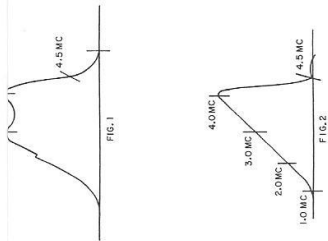

CHROMA  
TAKE-OFF

(V19)  
6EW6  
BURST  
AMP.

TP-  
Y3

(V21)  
6AL5  
KILLER  
DET.

(V22)  
6AL5  
AFC PHASE  
DET.

(V18)  
6CH8  
CHROMA  
AMP AND  
KILLER

TL1009  
BAND  
PASS  
TRANS.

L1007  
REACT.  
CONTROL

(V20)  
6GH8  
3.58 MC OSC.  
& REACT.  
CONTROL

TP-  
Y2

TL1010  
3.58  
OSC.  
TRANS.

(V24)  
6GY6  
DEMODUL-  
ATOR

(V23)  
6GY6  
DEMODUL-  
ATOR

(V26)  
6GU7  
RED AND  
GREEN  
AMP.

(V25)  
6GU7  
BLUE AMP  
& HORIZ  
BLANKER

### SERVICE NOTE CY-1 (CHROMA) UNIT

A faulty chroma (CY-1) Unit may prevent reception of both black-and-white and color pictures. Normal black-and-white reception, however, can be obtained with the CY-1 Unit removed from the receiver. If Unit is removed, it is usually necessary to readjust kine bias, screen, and cathode-drive controls (normal color temperature adjustments). Color temperature adjustment may also be required if CY-1 Units are exchanged, or if tubes are changed in normal service.

### CHROMA BANDPASS ALIGNMENT:

Test Equipment: Video sweep generator; video marker generator (if markers are not included in the sweep generator); oscilloscope with video detector probe.

1. Remove video IF strip (Unit CB-1) from chassis. Turn color control and color killer control to full "on" position (clockwise).
2. Connect oscilloscope, through detector probe, to "on" side of color control. Connect video sweep generator to TP Y-1. Adjust sweep generator output to maintain a one volt (peak to peak) display on the oscilloscope. Adjust top and bottom cores of TL-1009 to produce the curve shown in Fig. 1. Marker frequencies are shown on the curve. Cores must be on opposite ends of the coil.
3. Connect video sweep generator to terminal B12. Adjust TL-1008 to produce the curve of Fig. 2. Maintain one volt pattern on os-

cilloscope. Core must be peaked at chassis end of coil. Recheck TL-1009 if necessary.

4. Replace CB-1 Unit in chassis.

### COLOR SYNC AND PHASE ADJUSTMENT:

Test Equipment: Color bar generator; VTVM.

1. Connect color bar generator across antenna terminals. Tune generator and receiver to an unused channel. Turn color control and killer control fully clockwise. Set tint control to mid-range.
2. Connect VTVM to TP Y-2 through a 470 k. resistor. Adjust TL-1010 and TL-1011 for maximum reading on VTVM. 3.58 MC oscillator must be operating and locked in. Remove VTVM.
3. Ground test point TP Y-3. Adjust L-1007 until color bars move slowly or remain stationary. Remove ground from TP Y-3. Check color sync action. Remove color bar generator and adjust killer control until color snow just disappears.

---

## REPLACEMENT PARTS

The items listed below are of specific design normally used in regular maintenance, and which we recommend for replacement.

Items not listed may be obtained by writing to our Parts Department, giving complete description of the required part, together with chassis and receiver models in which it is to be used. (Minimum order: \$1.00).

Prices subject to change without notice.

### UNIT CY-1

L-1007	Reactance control coil.....	\$1.25
TL-1008	Chroma take-off transformer.....	1.25
TL-1009	Band-pass transformer.....	2.50
TL-1010	3.58 MC Oscillator transformer.....	1.50
TL-1011	Burst phase transformer.....	1.75
X-1018	3.58 MC Crystal.....	7.00
L-1013	620 microhenry peaking coil.....	.50
LC-106	12 microhenry rf choke.....	.50
R-1045	27 k. 3 w. 5% tolerance resistor.....	.50

## REPLACEMENT PARTS

The items listed below are of specific design normally used in regular maintenance, and which we recommend for replacement.

Items not listed may be obtained by writing to our Parts Department, giving complete description of the required part, together with chassis and receiver models in which it is to be used. (Minimum order: \$1.00).

Prices subject to change without notice.

### CABINET COMPONENTS:

M-1046	Picture tube mask.....	\$20.00
ZB-1047	Mounting band assembly .....	5.00
SD-1048	Purity shield .....	2.50
CP-1049	Picture tube base cover (part of cabinet back) .....	2.50
CP-1050	Escutcheon plate, VHF .....	2.00
CP-1051	Escutcheon plate, VHF-UHF .....	2.50
K189	Knob (volume, tone, brightness).....	.70
K190	Knob (microtuning, color, tint, brightness).....	.55
K173	Knob, pre-set fine tuning .....	.40
K191	Channel selector knob, VHF .....	1.80
K192	Tuning knob, UHF .....	1.00
K179	Calibrated rim dial, UHF .....	.80
SP-1052	6" Speaker, low frequency, with terminal board.....	6.25
SP-1053	6" Speaker, high frequency .....	6.25



# PICTURE TUBE CIRCUITRY

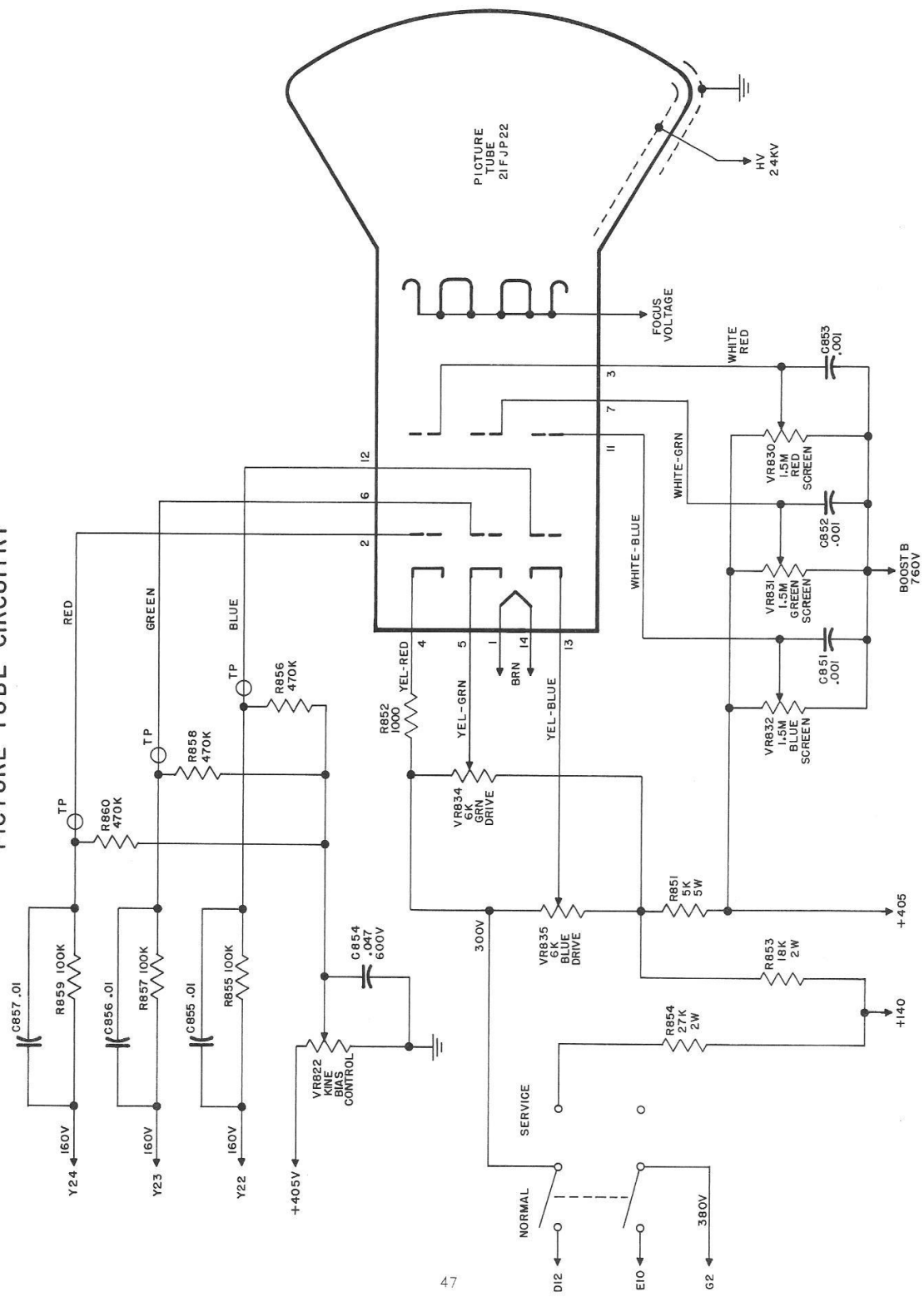

COLOR SERVICE NOTE NO. 1: "SNIVETS"

"Snivets" are a form of interference produced by high-frequency oscillation within the horizontal output tube. They should not be confused with the old familiar Barkhausen oscillation, since snivets appear in different parts of the raster as ragged vertical lines or weird distortions of vertical stripes and broken lines. While snivet interference is usually bothersome only on UHF reception, it may be occasionally seen on weak VHF channels.

Snivets may be minimized by placing a positive potential on the suppressor grid of the 6JE6. The circuit shown below, used in current production of the U800 color chassis, places a positive voltage of approximately 30 volts on the suppressor (pin 8). Pin 8 has been disconnected from ground and fed from the screen supply through the 22 k. 1 watt resistor. The .01 mfd ceramic disc by-pass capacitor is also added.

If a snivet problem exists, check the circuitry of Unit CF-1 and modify in accordance with the sketch if the components mentioned are not already incorporated. In extreme cases, it may be necessary to exchange 6JE6 tubes.

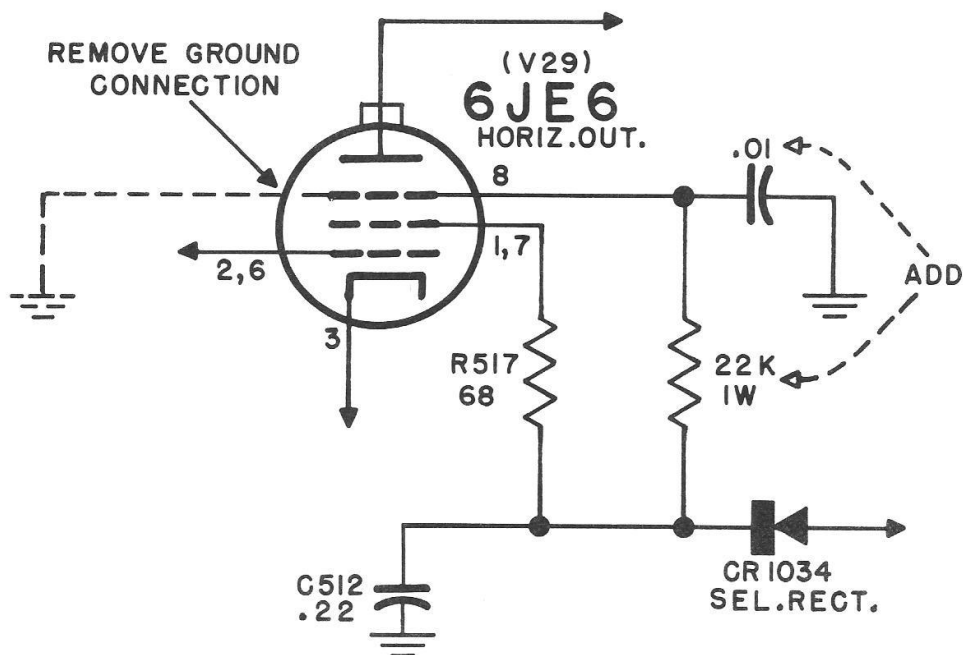

COLOR SERVICE NOTE NO. 2: VERTICAL "BOUNCE"

Vertical "bounce" or slight jitter due to rapid line voltage fluctuations has been minimized by connecting a .1 mfd 1000 volt capacitor between the wiper arm (orange lead) of the vertical size control and chassis. This capacitor may be added to existing receivers without removing the chassis from the cabinet. The ground lead may be soldered to the same lug to which the electrolytic capacitor (underneath the size control) is attached. When the capacitor is added, it will be necessary to readjust vertical size and linearity controls.

### COLOR SERVICE NOTE NO. 3: DIAGRAM CORRECTIONS

1. PAGE 11: Main Chassis Component diagram should show connections between plus 405 v. and the left terminals of the red and green screen controls, VR830 and VR831. Blue control, VR832, is correct.

On some chassis, the two 100 mfd 450 v. electrolytic capacitors, C858 and C859, have been moved to a location in the main chassis underneath Unit CF-1.

2. PAGE 25: Tuner Assembly CA-1 diagram shows a dual 10k Micro-Tuning control which is used only on UHF models. VHF-only receivers have a single 4k control and resistor R12 is 470 ohms.
3. PAGE 35: Unit CF-1 production changes include the snivet reduction circuit described in Service Note 1. C508 has been changed to 180 mmf. R522 is now 47k 1 watt.
4. PAGE 41: Unit CY-1 diagram shows the isolation networks R737-C734, R738-C736, and R742-C739, as part of the Chroma Unit. These networks are a part of the main chassis wiring, as shown on pages 11 and 47. Please correct the CY-1 Unit diagram to show direct connections between the output terminals and the respective amplifier plates.

COLOR SYNC ADJUSTMENT may be made more accurately by removing V19, the 6EW6 burst amplifier, from the socket instead of grounding TP Y-3 as described in the manual procedure. This applies only to adjustment of L-1007. V19 must be operating during all other chroma adjustments.

### COLOR SERVICE NOTE NO. 4: CONSOLETTA CABINET STYLE RECEIVERS

Color receivers using the consolette cabinet styles will differ from the console models described in the manual. Horizontal hold, vertical hold, and contrast controls are mounted as a separate assembly and are found at the right front bottom of the cabinet. The convergence control panel is mounted horizontally, and swings out for adjustment. The service door is not hinged, but lifts entirely out. The electrical circuitry and adjustment procedure coincides with that of the consoles.

### COLOR SERVICE NOTE NO. 5: SET-UP OF A NEW RECEIVER

This is a reminder that it is seldom necessary to perform all of the purity and convergence adjustment steps outlined in the manual except when a new picture tube is installed. We suggest that the receiver be degaussed and purity checked before removing the cabinet back. Unless the deflection yoke, purity magnet, or static convergence magnets must be moved, only slight touch-up of the dynamic convergence controls will be needed. Any of the dynamic controls will interact somewhat with others, so it is important to make adjustments in the order outlined and not turn controls unnecessarily.

**WARNING:** Improper adjustment of the H.V. Regulator Control will reduce horizontal sweep and make it impossible to attain good focus, purity, convergence, or gray scale tracking. See procedure on page 36.

