

# How to Build a Television Receiver

THE ARRANGEMENT OF THE SCANNING DISC AND RESISTANCE COUPLED AMPLIFIER  
HERE DESCRIBED IS VERY COMMENDABLE

BY FRED H. CANFIELD

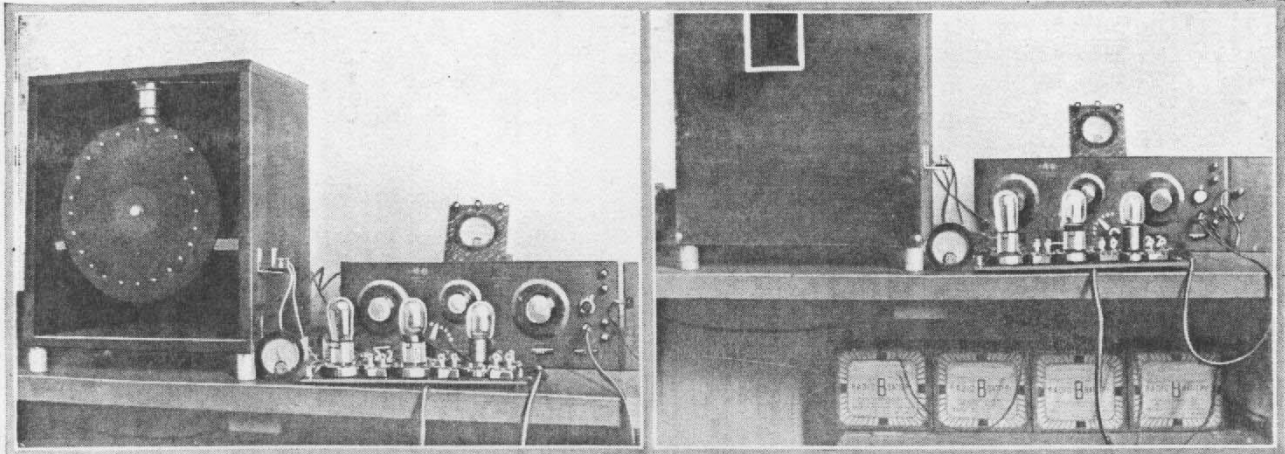

Photo above shows neat arrangement of amateur television receiving apparatus. The resistance coupled amplifier is shown at right and the disc cabinet at left.

Here we see the disc cabinet at left with cover removed. The neon tube can be seen directly behind the disc. The amplifier appears at right.

LESS than two years ago it was rumored in engineering circles that television might be practical within a decade or so, but much doubt was expressed as to whether it would ever be developed to a practical basis. It was said that hundreds of photoelectric cells would be required at the transmitting station to "pick-up" the picture and that an equal number of neon lamps would be needed at the receiving end to reproduce the image. This system, of course, would make both the receiving and transmitting installations very expensive, and the use of television broadcasting for home entertainment would be entirely out of the question.

Today conditions are very different. Greatly simplified systems for the transmission and reception of television have been discovered, and the public is now anxiously awaiting the day when *home television* will be declared an established fact. Already broadcasting stations are placing television programs on the air on a regular schedule, and many experimenters throughout the country have built television receivers. The signals which are being transmitted and received are far from perfect, but the progress which has been made in this direction during the past two years greatly exceeds the most enthusiastic predictions which were recklessly made in previous years.

When contrasted with yesterday's conception of television apparatus, the modern television sending and receiving stations will be found absurdly simple. At the transmitting end a single photo-electric cell (or else 3 to 4 large ones) is used to pick-up the picture, and the output of this cell is connected with an audio-frequency amplifier which amplifies the current from the cell before delivering it to the transmitter. A device known as a scanning disc makes it possible for the single photo-electric cell to do the work which would require hundreds of cells with other systems. This disc is punched with holes in a spiral path, and it allows the cell to photograph all parts of the picture fifteen times each second. At the receiving end the apparatus is similar to the transmitter but it operates in the reverse order. A standard broadcast receiving set followed by a high-quality audio amplifier is employed, and the output is connected with a

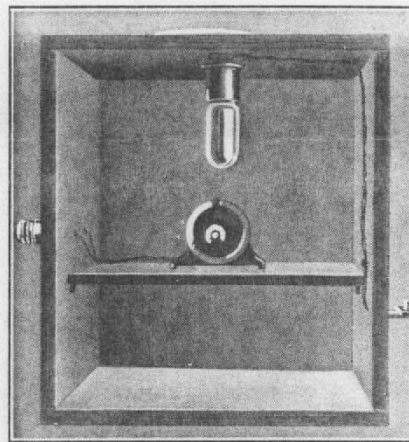

The picture above shows the interior of the cabinet with the motor and neon tube in place.

single neon lamp. Also, a scanning disc, exactly the same as the one used at the transmitter, is placed between the eye of the observer and the neon lamp. The chief problem in receiving the image is to have the scanning disc revolve in exact synchronism with the disc at the transmitter.

With apparatus of the type described in the above paragraph an image approximately one inch square is received. The image is a half-tone in character, and when distortion has been reduced to a minimum, and the discs are in perfect synchronism, the definition of the picture should be very satisfactory as it is composed of from 24 to 50 lines per inch. The average newspaper half-tone has 50 to 60 lines per inch, and, therefore, under ideal conditions television may be practically the same in quality.

## A Typical Amateur-Built Televisor

THE pictures which appear on this page provide an example of the average amateur television receiving installation. This station is owned by a New Jersey experimenter and is entirely home constructed. The owner is

Mr. Albert E. Sonn, 66 Yantacaw Ave., Bloomfield, N. J. Mr. Sonn is well known in amateur circles as operator of station 2GC, and his name is also familiar to many broadcast listeners who have heard his informative talks on radio from various New Jersey stations.

An interesting feature of the station shown in the picture is that it is of very simple construction and it is very inexpensive to assemble. Both the receiver and audio amplifier are of more or less standard construction, and the only special parts required are the neon lamp, the scanning disc and a small universal motor. The radio receiving set shown in the picture is an early design of broadcast receiver, yet it is entirely satisfactory for the purpose. It happens to be a two-variometer-type regenerative set, but any standard tuned R.F. tuner would work just as well, provided it did not distort the incoming signals. However, it would be inadvisable to use a superheterodyne receiver for television reception, as the usual intermediate-frequency amplifier will cut sidebands sufficiently to cause serious distortion of the image.

The audio amplifier in a television receiver is a very important consideration as distortion must be reduced to an absolute minimum, and at the same time the output must be comparatively high. It has been found that a resistance-coupled amplifier is the only type which provides entire satisfaction, and at least three stages are needed. Also, the tube in the last stage should be a 210- or a 250-type in order to provide the neon lamp with enough energy to produce a good picture. The amplifier used with the receiver shown in the above pictures consists of a standard resistance-coupled unit which has been rewired for power-tube operation. Two 240-type hi-mu tubes are used in the first two stages and a 210-type tube is used in the output stage. Maximum plate voltage is used on the first two tubes and 300 volts is applied to the plate of the power tube. The grid bias of all tubes is adjusted carefully to prevent distortion.

The pictures clearly show the simplicity of neon tube-scanning disc combination. A box slightly larger than the scanning disc is employed and this is painted black both inside and out in order to reduce reflection.

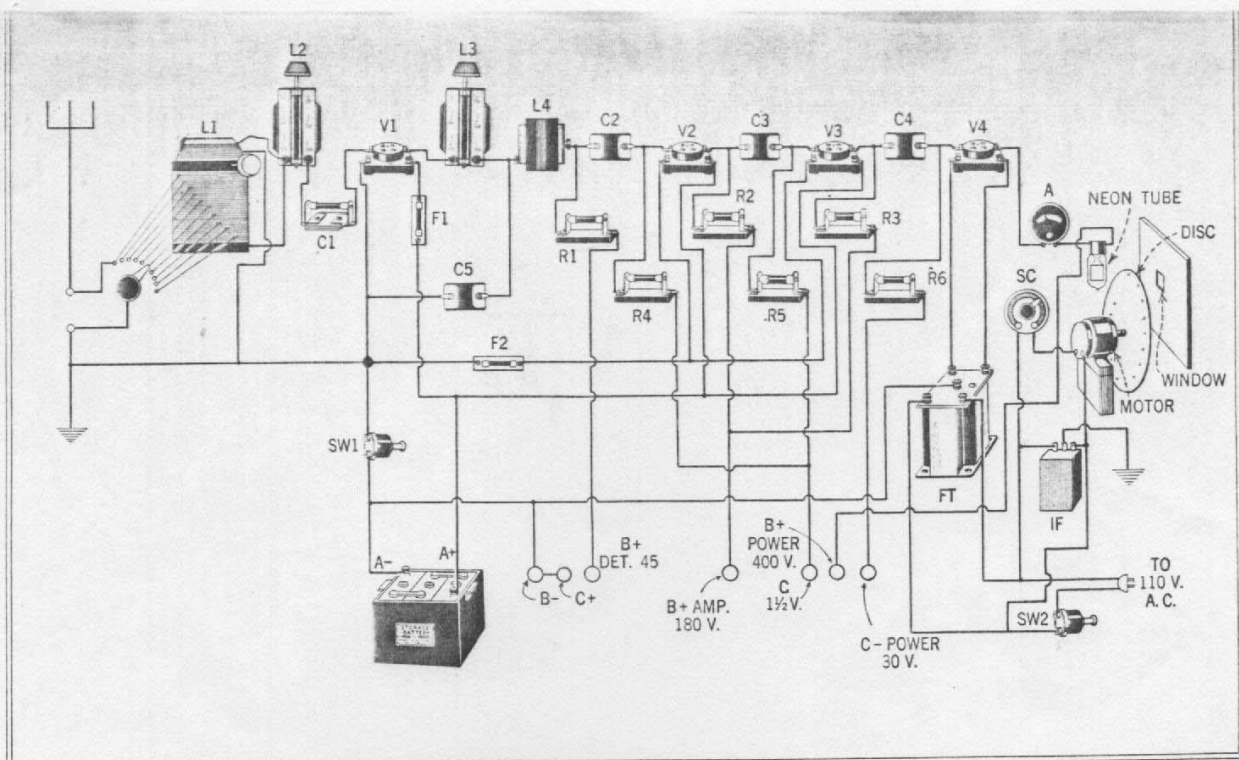

This picture diagram shows the wiring of a complete television receiving set. It consists of a standard regenerative tuner, followed by a resistance-coupled A.F.

amplifier, with the usual neon tube in the plate circuit of the power tube. A rheostat in series with the motor serves as a synchronism control for the disc.

For the benefit of those who are contemplating the construction of experimental television receivers, the diagrams on this page give details of the set pictured in the illustrations. It is not essential that these drawings be followed exactly, as many variations are possible. However, they show the exact circuit which was selected by Mr. Sonn.

The receiver is a standard three-circuit regenerative set of the double-variometer type. L1 is a variocoupler with a tapped primary and a rotating secondary winding. L2 and L3 are variometers of identical design. These are the type ordinarily used in broadcast receivers and are designed to cover the wave band of 200 to 600 meters. L4 is a standard R.F. choke coil, which is employed to prevent R.F. current from entering the audio amplifier. The grid condenser C1 has a capacity of .00025 mf., and the resistance value of the grid leak R7 is selected after experimenting with leaks of various values. F1 is a 5-volt, 1/4-ampere filament-ballast unit and C5 is a .002 mf. by-pass condenser. All of the parts mentioned in the above are housed in the receiver cabinet.

The audio amplifier is a standard three-stage resistance-coupled unit. V2 and V3 are HiMu amplifier tubes of the 240 type, and V4 is a 7 1/2-watt power amplifier tube of the 210 type. C2, C3 and C4 are coupling condensers, having a capacity of approximately .01 mf. each. R1 has a resistance of .1 meg., while R2 and R3 have a resistance of 250,000 ohms each. The value of the resistors R4, R5 and R6 must be determined by experiment, but usually it will be approximately 250,000 ohms for R4 and R5 and 100,000 ohms for R6.

The "B" power for the entire receiver is provided by batteries. Four hundred volts of dry cells are required for the power tube and taps at 180 volts and 45 volts are needed for the amplifier and detector tubes, respectively. Thirty volts of "C" battery is required for the power tube and 1 1/2 volts is needed for the first two audio tubes. The filament of the power tube is heated with 7 1/2 volts of A.C., which is provided by a

step-down transformer FT. Lower "B" voltage yields a dimmer image.

The neon tube is connected in the circuit exactly as the loud speaker, that is, in series with the plate-supply wire to the power tube V4. Also, a milliammeter is connected in series with the tube to facilitate adjustment of the grid battery. The motor used for turning the scanning disc is a standard (110-volt A.C.-D.C.) small-size universal motor, and a suitable rheostat (SC) is used as a speed control. (A 6-volt battery motor and storage battery may be used, with rheostat.) In order to prevent the arcing at the brushes of the motor from interfering with the reception, an interference filter (IF) is connected across the 110-volt A.C. line. For turning the set on and off two switches are required; SW1

closes the storage-battery circuit and SW2 connects the 110-volt supply with the filament transformer and motor.

A box 18 inches square, as shown, provides ample space for the 12-inch, 24-hole scanning disc. However, if larger discs are to be used, the size of the cabinet must be increased proportionally.

After setting up the receiver, the first problem is to make sure that the set operates at maximum efficiency. It is best to disconnect the neon tube temporarily, and in its place connect a standard loud speaker. Now, use the set as a broadcast receiver and make the necessary adjustments until the most perfect voice reproduction is obtained; that is, adjust the grid-bias voltages and experiment with various size resistors in the audio circuits. When the set is performing properly, the neon tube may be connected into the circuit.

Before it is possible to receive television signals, it is necessary to know whether sufficient amplification is being obtained to properly operate the neon tube. With the neon tube connected and the scanning disc revolving tune in the signal of a broadcasting station and note the results. If the station has a strong signal, the music and voice should cause the appearance of distinct geometric designs in the observation window. Also, when a signal is not being received, the tube should give off a steady glow; and when looking through the window, the screen will be perfectly clear, with the exception of fine parallel lines which are hardly noticeable.

The receiver is now ready to pick up the television picture. When a television program has been tuned in the only problem is to adjust the speed of the disc to synchronism with the disc at the transmitting station. This is accomplished with the motor speed-control rheostat (SC). It may require considerable experimenting before the speed of the receiving disc is brought into synchronism, but after a little practice, it will not be found so difficult. In this connection a revolution counter is valuable as the disc should revolve at approximately 900 R.P.M.

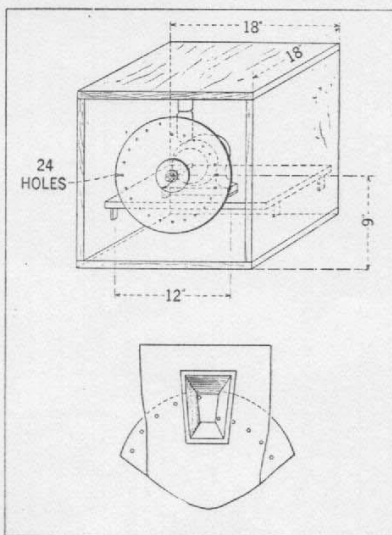

These drawings clearly show the construction of the scanning disc cabinet.