

Introduction

I found these books to be very helpful for specific problems and troubles as found and documented by the TV manufacturers themselves during the 50's. I decided they would be helpful to others in the hobby of fixing up and obsessing over old TV's like myself. Please let me know if you see any issues with the scans or need clarification on something that is not clear/visible in a scan.

From the general preface:

This is a series of volumes which deal with specific TV receiver troubles and their cures. These trouble cures are the TV manufacturers' answers to some of the problems that may arise in their particular receivers.

After a certain model or chassis has been in the field for a while, certain troubles may occur which are peculiar to that receiver. In an effort to maintain his own good reputation, the manufacturer is interested in keeping his receiver in tip-top working order. Therefore, his service or engineering department evolves a cure for the particular trouble.

The question may be asked, "Why doesn't the manufacturer incorporate the cure into future production runs on his own receiver? The answer is that he frequently does. However, it is certainly not possible, with such a complex device as a TV receiver, to hold off on production until every single "bug" has been removed. The fact remains that many receivers are in the field and do develop certain peculiarities of operation for which the manufacturer has a definite tried-and-tested cure. Many of these cures will be found in these volumes.

In addition, the development of new ideas and circuitry is unending. These new ideas are conceived by TV receiver manufacturers and many of the circuits can be incorporated into receivers already in the field. Such changes will improve the operation of the receiver, especially under unusual or difficult operating conditions. What is more, in areas of high humidity, in fringe areas, in strong-signal areas, etc., certain troubles are apt to occur. Many of the manufacturers' trouble cures given in this volume will alleviate these troubles when properly applied to the receiver in question.

You will note that these volumes contain valuable information relating to trouble cures and circuit changes which will actually improve the operation of the TV receiver. You will not be given generalized instructions to "check this capacitor" or "check that tube" if a certain trouble appears. Instead, you will be given exact directions as to the specific operation to be performed in affecting the cure. In all cases where components are identified, the manufacturers own circuit symbol is used. This makes it easy to utilize the information given in these pages along with Rider Manuals and Tek-File. A complete index in which trouble cures are listed by brand and chassis or model number appears at the end of this volume.

Volumes

There are seven volumes available (that I know about). Volumes 1-5 cover most sets and were published between 1953 and 1954. Volumes 6 and 7 cover newer sets in 1954 and 1955 and include some updates for brands covers in earlier volumes.

Volume 1			
Cat. No. 143-1, 115 Pages, Published January, 1953			
Admiral	Air King	Andrea	Arvin
Belmont-Raytheon	Bendix	Calbest	Caphart-Farnsworth
CBS-Columbia	Certified	Crosley	DuMont

Volume 2			
Cat. No. 143-2, 117 Pages, Published February, 1953			
Emerson	Fada	Firestone	Freed
Gamble-Skogmo	General Electric	Hallicrafters	Hoffman
Industrial TV	International TV	Jackson	
Volume 3			
Cat. No. 143-3, 119 Pages, Published April, 1953			
Kaye-Halbert	Kent	Magnavox	Majestic
Meck	Mercury	Midwest	Montgomery Ward
Motorola	Muntz	National	North American Philips
Olympic	Pacific Mercury	Packard-Bell	Philco

Volume 4			
Cat. No. 143-4, 120 Pages, Published July, 1953			
Philharmonic	Pilot	Radio and Television (Brunswick)	RCA Victor
Remington (Rembrandt)	Scott	Sears Roebuck	Sentinel
Setchell Carlson	Shaw TV		

Volume 5			
Cat. No. 143-5, 119 Pages, Published March, 1954			
Sparton	Stewart-Warner	Stromberg-Carlson	Sylvania
Tele King	Trad TV	Transvision	Trav-ler
Wells-Gardner	Western Auto (Truetone)	Westinghouse	Zenith

Volume 6			
Cat. No. 143-6, 120 Pages, Published November, 1954			
Admiral	Aimcee (AMC)	Arvin	Bendix
Cadillac TV	Capehart	CBS-Columbia	Conrac
Crosley	DuMont	Emerson	Firestone

Volume 7			
Cat. No. 143-7, 112 Pages, Published June, 1955			
General Electric	Hallicrafters	Hoffman	Jackson
Kaye-Halbert	Magnavox	Majestic	Mars TV
Mattison TV	Meck	Montgomery Ward	Motorola
Muntz	Pacific Mercury	Packard-Bell	Philco
Philharmonic	Radio Craftsmen	Raytheon	

All volumes scanned by mbear2k (Mark) - mbear2k@oldtubes.net

TV

*class
works*

MANUFACTURERS' RECEIVER TROUBLE CURES

VOLUME 4

(CAT. NO 143-4)

Philharmonic

Pilot

Radio and Television

(Brunswick)

RCA Victor

Remington

(Rembrandt)

Scott

Sears Roebuck

Sentinel

Setchell Carlson

Shaw TV

A RIDER Publication

Copyright 1953 by

JOHN F. RIDER PUBLISHER, INC.

*All rights reserved including that of translation into
the Scandinavian and other foreign languages.*

Library of Congress Catalog Card Number: 53-698

Printed in the United States of America

P R E F A C E

This is the fourth in a series of volumes which deals with specific tv receiver troubles and their cures. These trouble cures are the tv manufacturers' answers to some of the problems that may arise in their particular receivers.

After a certain model or chassis has been in the field for a while, certain troubles may occur which are peculiar to that receiver. In an effort to maintain his own good reputation, the manufacturer is interested in keeping his receiver in tip-top working order. Therefore, his service or engineering department evolves a cure for the particular trouble.

The question may be asked, "Why doesn't the manufacturer incorporate the cure into future production runs of his own receiver?" The answer is that he frequently does. However, it is certainly not possible, with such a complex device as a tv receiver, to hold off on production until every single "bug" has been removed. The fact remains that many receivers are in the field and do develop certain peculiarities of operation for which the manufacturer has a definite tried-and-tested cure. Many of these cures will be found in this volume.

In addition, the development of new ideas and circuitry is unending. These new ideas are conceived by tv receiver manufacturers and many of the circuits can be incorporated into receivers already in the field. Such changes will improve the operation of the receiver, especially under unusual or difficult operating conditions. What is more, in areas of high humidity, in fringe areas, in strong-signal areas, etc., certain troubles are apt to occur. Many of the manufacturers' trouble cures given in this volume will alleviate these troubles when properly applied to the receiver in question.

You will note that this volume contains valuable information relating to trouble cures and circuit changes which will actually improve the operation of the tv receiver. You will not be given generalized instructions to "check this capacitor" or "check that tube" if a certain trouble appears. Instead, you will be given exact directions as to the specific operation to be performed in affecting the cure. In all cases where components are identified, the manufacturer's own circuit symbol number is used. This makes it easy to utilize the information given in these pages along with *Rider Manuals* and *Tek-File*. A complete index in which trouble cures are listed by brand and chassis or model number appears at the end of this volume.

The editor wishes to acknowledge the cooperation of the following tv receiver manufacturers who furnished the information contained in this volume to John F. Rider Publisher, Inc.

PHILHARMONIC

SCOTT

PILOT

SEARS ROEBUCK

RADIO AND TELEVISION
(Brunswick)

SENTINEL

RCA VICTOR

SETCHELL CARLSON

REMINGTON (Rembrandt)

SHAW TV

July, 1953

Milton S. Snitzer

West's Radio Service

Prairie Du Chien, Wis.

Phone A211 812 S. Ohio St.

CONTENTS

MFR. MODEL	PAGE	MFR. MODEL	PAGE
PHILHARMONIC	1-3	TC124	
C6161	1-2	9-10, 12-13, 25-26	
T616	1-2	TC125,	
20C2B, 20CD2B	1-3	-127	9-10, 25-26
20T2B	1-3	TC165, -166, -167,	
61	1	-168	9-10, 27-29
111, 112	1-3	4T101, -141	5-6
616	1	6T53, -54, -64, -65,	
724-924-924	1-3	-71, -74, -75, -76,	
820-920	1-3	-84, -86, -87	6-9
1116	1-2	6T72	10
5221	1-3	7T103, -104,	
5816	1-2	-111, -112	5-8
8120-9120	1-3	7T122, -123,	
8820-9820	1-2	-124, -125	5-9
		7T132, -143	5-6
PILOT	3-4	8T241,	
TV-127	3-4	-243, -244	10-12
TV-164, -167A,		8T270	12-13
-167B, -168	3	9T57, -77,	
TV-191, -192	3	-79, -89	6-9, 13-15
TV-271, -273, -274	3-4	9T105, -126,	
TV-293, -294	3-4	-128	5-6
		9T147	5-9
RADIO AND TELEVISION		9T246, -270	12-13
(Brunswick)	4-5	9TC245, -247,	
616	4-5	-249	12-14
1116	4-5	9TW390	14
6161	4-5	16T152	7-9
		16T153, -154,	
RCA VICTOR	5-44	-164, -165, -171,	
S1000	14, 24-25	-174, -175, -176,	
T100,		-184, -186, -187	14-15
-120	12-13, 25-26	17T150, -151	15-19
T121	12-14	17T153, -154,	
T164		-155	10, 15-23
9-10, 12-13, 27-29		17T160,	
TA128, -129		-162	10, 15-23
9-10, 12-13, 25-26		17T163	15-19
TA169	9-10, 13, 24-25	17T172, -173,	
		-174	10, 15-23

v

MFR. MODEL	PAGE
17T172K, -173K, -174K	15-18
17T200, -201, -202, -211, -220	23-24
21T159, -165	15-19, 24
21T174	24
21T176, -177, -178, -179,	15-22, 24
21T208, -217, -218, -227, -228, -229	23-24
Models with	
KRK2 tuners	29-32
KRK5 tuners	29-35
KRK7 tuners	29-35
KRK8 tuners	29-32, 35
KRK11 tuners	35
Models with	
10BP4 picture tubes	35-36
12LP4 picture tubes	35-36
16AP4 picture tubes	35-36
17CP4 picture tubes	37-38
17GP4 picture tubes	38-39
17QP4 picture tubes	37
19AP4A picture tubes	39
21AP4 picture tubes	37
Models with metal picture tubes	39-40
All models with EM-PM focus coils	40-41
All models	41-44

REMINGTON

(Rembrandt)	45
80, 130	45

MFR. MODEL	PAGE
SCOTT	45-46
710, 720	45-46
910, 920 924	45-46
SEARS ROEBUCK	46-94
100.107, -111, -112, -115, -120, -121	46-52
100.208, -209	52-53
100.499	53
100.700-1 through -140	54
101.846, -854, -865, -866, -867, -868	54-57
Chassis 106 series	57-58
Chassis 110 series	58-59
110.499	59-61
110.700 series	61-64
110.700-1, -2, -90, -120, -140, -900	64-65
110.702-10, -50	65
Chassis 132 series	65-66
132.889, -890	66-72
Chassis 132.890 series	69-71
Chassis 478 series	72-74
478.303, -319, -321, -338, -339, -339B, -361, -361A, -375, -376	75-77
528.630, -631, -632	77-80
Chassis 549.100 series	80-81
549.100	80
549.100-5, -8, -9	82
Chassis 549.101 series	82
Chassis 549.102 series	83
549.102	82-84
1950 549-series chassis	84-85
1141-20	85
All chassis with	
focus magnet	85-86
electrostatic focus	86-88
GI tuner	88
1X2	88
built-in antenna	88
75-ohm input	88-89

MFR.	MODEL	PAGE	MFR.	MODEL	PAGE
	All chassis in console cabinets	89		432, 438, 439	99-100, 103-104
	All chassis	89-94		440, 441, 443, 444, 446, 447, 448, 449	99-100, 103-104
SENTINEL		94-108		450, 451, 454, 455, 456, 457	103-106
	400-1, -2, -5, -6, -11	94-95		All models	106-108
	401-1, -2, -6, -7, -9, -11	95			
	402CV, 406CV, 411CV	95-96	SETCHELL CARLSON		108-113
	411, 412, 413, 414, 415, 416	95-99		152, 153	108-113
	419, 420, 421, 422, 423, 424, 425	95, 99-103	SHAW TV		113-115
	428	95-101		224	113-115



PHILHARMONIC Models 61, 616,
5816, X6001

Replacement of horizontal-output transformer.

To replace old horizontal-output transformer with a new unit, proceed as follows:

1. Remove old transformer and wires that are connected to it.

2. Insert new 80-265 or 80-265-1 transformer.

3. Place a black lead on pin 8 of the new flyback (horizontal-output) transformer and ground the other end.

4. Place a red lead on pin 7 of the flyback and solder to B+ (low side of C54, .1- μ f blocking capacitor in series with horizontal-yoke winding). Solder one side of width coil to pin 7 of flyback.

5. Solder other side of width coil to pin 6 of flyback.

6. Place a yellow lead on pin 1 of flyback and solder to one side of high-voltage fuse. The other side of the fuse goes to junction of C51 and L13 (horizontal-linearity coil).

7. Solder blue wire to pin 9 of flyback and run wire to open end of R51 (15-k resistor leading to 6AL5 socket).

8. Solder a green wire to pin 4 of flyback and run wire to pin 5 of 6W4.

9. Solder red wire to pin 5 of flyback and run wire to high side of horizontal pin 1 on yoke (usually brown lead, leading from yoke).

10. When using 80-265 transformer, place filament leads of flyback on pin 2 and pin 7 of 1B3 socket.

11. When using 80-265-1 flyback, place a 3.3-ohm resistor in series with the short filament lead and cover resistor and lead with insulation. Place other filament lead on pin 7 of 1B3 socket and loose end of 3.3-ohm resistor to pin 2 of 1B3 socket.

PHILHARMONIC Models 111,
112, 724-924-924,
820-920, 1116,
5221, 5816,
8120-9120,
8820-9820, 20C2B,
20CD2B, 20T2B,
C-6161, T-616

Critical horizontal drive.

With any set that may have its drive control operated near the closed position so that the drive control is critical, replace R63 (56-k resistor connected between one side of the horizontal-linearity coil and the plate circuit of the horizontal oscillator) with a 120-k resistor. The part number for this new resistor is 60-817.

PHILHARMONIC Models 111,
112, 724-924-924,
820-920, 1116,
5221, 5816,
8120-9120,
8820-9820, 20C2B,
20CD2B, 20T2B,
C-6161, T-616

Black bars on left side of raster (see Fig. 1).

When black bars appear on the left-hand side of the raster, make the following changes for their elimination:

1. Place a 3.3-ohm resistor in series with C52 (.05 μ f) to ground. This capacitor, shown in the figure,

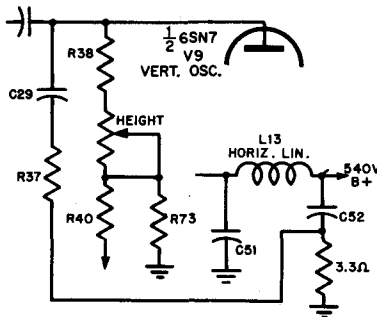

Fig. 1 — Philharmonic

is connected to one side of the linearity coil.

2. At the junction of C52 and the 3.3-ohm resistor, place a wire to the ground side of R37, the 8.2-k peaking resistor in the plate circuit of the vertical oscillator.

3. Remove the ground connection from R37.

PHILHARMONIC

Models 111,

112, 724-924-924,
820-920, 1116,
5221, 5816,
8120-9120,
8820-9820, 20C2B,
20CD2B, 20T2B,
C-6161, T-616

Excessive height.

If the set seems to have excessive height which the controls do not cut down far enough, replace R38 (2.7-meg resistor connected to one side of the height control) with a 3.3-meg resistor (part No. 60-693).

PHILHARMONIC

Models 111,

112, 724-924-924, 820-920, 5221, 8120-9120, 8820-9820, 20C2B, 20CD2B, 20T2B

Multiple image due to parasitic oscillation.

Due to the premature failure of some of the 6BQ6 tubes (horizontal output) which seem to have a wide

departure from published specifications, there has been a considerable run of tube failures in the respect that there is a double or triple image. We recommend two changes to alleviate this condition. They are as follows:

1. When adjusting the linearity coil, there are two positions for good linearity. For best results adjust this coil toward the outer position (minimum inductance).

2. In the cathode circuit of the 6BQ6 there is a 27-ohm resistor which is not bypassed in series with 120-ohm resistor, that is bypassed. Add another resistor of 120 ohms at 2 watts in series with the 120-ohm resistor already in the circuit, making sure that both 120-ohm resistors are bypassed.

PHILHARMONIC

Models 111,

112, 724-924-924, 820-920, 5221, 8120-9120, 8820-9820, 20C2B, 20CD2B, 20T2B

Picture-tube operation in low line voltage areas (see Fig. 2).

If the set is going to be operated under conditions of low line voltages (less than 105 volts), make the following changes:

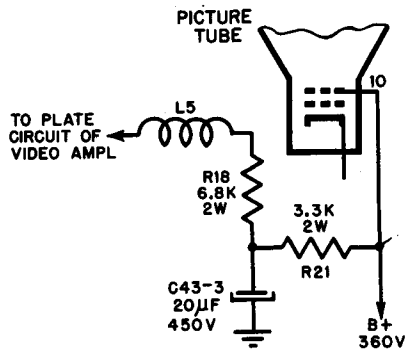

Fig. 2 — Philharmonic

1. Remove C58, .02- μ f, 1,000-volt capacitor connected between pin 10 of the picture tube and ground.

2. Remove R76, 10-k resistor connected to pin 10 of the picture tube.

3. Connect pin 10 of the picture tube to B+ 360 volts.

4. Connect the brown wire (filament lead) of the picture-tube socket to one of the empty terminal strips and connect a wire directly from this point to the green wire (filament voltage) of the power transformer.

These changes are necessary to increase the life of the picture tube due to the low line voltage causing the filament voltage of the tube to be lower than the allowable voltage.



PILOT

Models TV-127,
-164, -167A, -167B, -168,
-191, -192, G228

Horizontal jitter.

Horizontal jitter may be caused by crosstalk between the cathode of the picture tube and the deflection-yoke cable. To prevent this, dress the picture tube cathode lead (yellow) away from the deflection-yoke cable.

PILOT

Models TV-127,
-164, -167A, -167B, -168,
-191, -192

Picture smear and jitter due to overload (see Fig. 3).

In strong-signal areas, excessive input at the antenna terminals will produce picture smear and picture jitter. This is due to cross-modulation effects in the r-f amplifier which

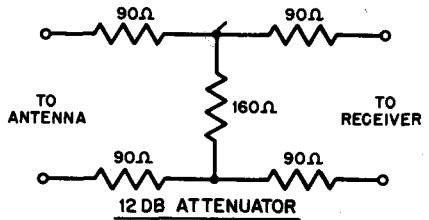
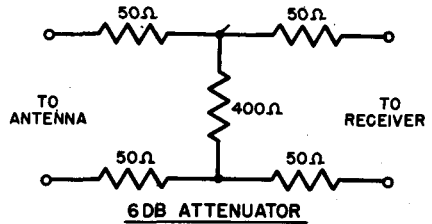

Fig. 3 - Pilot

may operate as a detector on the nonlinear portion of its curve near cut-off. An attenuation network at the antenna terminals will remedy this condition. A 6-db and a 12-db attenuator network are shown in the figure.

PILOT

Models TV-127,
-164, -167A, -167B, -168,
-191, -192, -271, -273,
-274, -293, -294

Hum or buzz at minimum volume-control setting.

To minimize hum or buzz in the sound at minimum setting of the volume control, dress the .05- μ f coupling capacitor to the 6AT6 grid away from the high-band oscillator coil.

PILOT

Models TV-271,
-273, -274, -293, -294

Vertical black lines in the picture.

Vertical black lines in the picture may be removed as follows:

1. On TV-271 and TV-273 check ground strap between speaker and yoke assembly for good contact.

2. On TV-274 and TV-294 check the two ground straps between the deflection-yoke assembly and the chassis for good contact.

3. Antenna transmission line must be dressed away from the deflection-yoke cable and yoke assembly.



RADIO AND TELEVISION

Models 616, 1116, 6161

Replacement of horizontal-output transformer (see Fig. 4).

The following is the method proposed to substitute the new type (part No. 80-263) horizontal-output transformer for the old in the above models.

1. Present transformer is to be removed from the chassis, disconnecting all leads.

2. The 15,000-ohm screen resistor on the 6CD6 (*R70*) is to be removed from chassis.

3. Place black lead from unmarked terminal to the same point where the previous black lead was connected.

4. Place green lead from lug 6 to the same point as previous green lead was connected (pin 6 of 6CD6).

5. Place orange lead from lug 7 to the same point as previous orange lead (B+ supply).

6. Place red lead from lug 4 to pin 5 on 6W4. Remove wire from yoke previously connected to pin 5 and place on empty pin 4 on 6W4.

7. Place white and black lead from lug 5 to pin 4 of 6W4, on which you

had previously connected the red wire from yoke.

8. Install a resistor (82,000 to 100,000 ohms, 3 watts) from the boosted B supply (yellow lead coming out from the fuse to the terminal strip) to the screen on the 6CD6 (ahead of the 100-ohm resistor), pin 1 being used as a tie point.

9. Place a 470,000-ohm, 1/2-watt resistor across the 8- μ f, 500-volt capacitor (*C55*) on the vertical-height control.

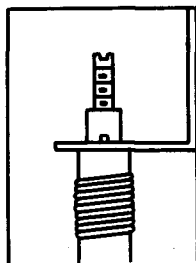

Fig. 4 — Radio and Television

10. It is extremely important that the width coil bracket be mounted with the base of the bracket placed down in the high-voltage compartment as shown, to give longer leads. The top of the winding is to be soldered to lug 6; the bottom of the winding is to be soldered to lug 7. Be careful to dress these leads away from the blue plate lead of the 6CD6 and the corona ring.

11. Place yellow lead from lug 1 to the fuse.

RADIO AND TELEVISION

Models 616, 1116, 6161

Preventing voltage breakdown.

To prevent voltage breakdown:

1. Dress the a-c choke on 1st video

i-f amplifier away from any sharp edges on the i-f shield.

2. Dress the high-voltage lead to the anode connection away from the 5U4 tube.

3. Dress the blue plate lead to the 6CD6 tube away from the width coil.

RADIO AND TELEVISION

Models 616, 1116, 6161

Misadjustment of horizontal-drive screw.

Some of these units had been misadjusted in the field as to the setting of the horizontal-drive screw.

The following is an outline of the procedure which must be adhered to, to gain the utmost from this unit: The horizontal-drive screw should be tightened and then turned counterclockwise until a white bar appears on the screen. When this bar appears, the screw should then be turned clockwise approximately $\frac{1}{4}$ of a turn until this bar disappears. Once this setting is achieved, the horizontal-drive screw should not be touched to adjust the linearity or width. The width coil and the linearity coil, which are located on the chassis, will be adequate to make any such adjustments.



RCA VICTOR Models 4T101, -141, 7T103, -104, -111, -112, -122, -123, -124, -125, -132, -143, 9T105, -126, -128, -147, Z206

Increased sound gain in fringe areas (see Fig. 5).

In those fringe areas where additional sound gain is desirable, the

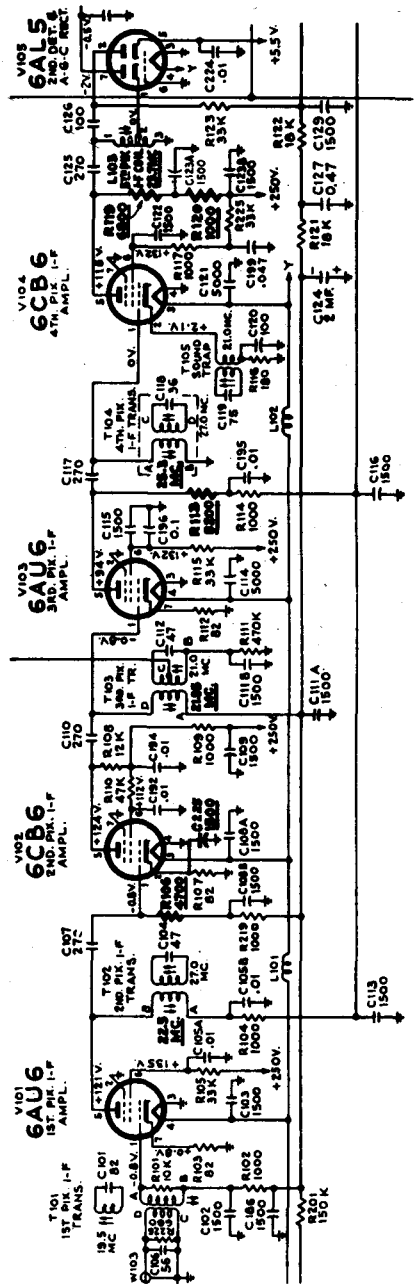

Fig. 5 - RCA Victor

following suggestion will effect up to a 4 to 1 increase in sound gain. See the figure for a partial schematic diagram showing the changes for model 7T103.

1. Change the second picture i-f grid resistor (*R106* in 17- and 19-inch models, *R107* in 14-inch models) from 8,200 to 4,700 ohms.

2. Change the third picture i-f plate-load resistor (*R113* in 17- and 19-inch models, *R115* in 14-inch models) from 1,800 to 8,200 ohms.

3. Change the fourth picture i-f plate-isolating resistor (*R120* in all models) from 6,800 to 1,000 ohms.

4. Remove the fourth picture i-f plate-load resistor and peaking coil (*R119* and *L114* in all models). In some cases, *L114* is wound on *R119*.

5. In place of *R119* and *L114* which were removed, install a 6,800-ohm resistor.

6. Add a 1,500- μ f ceramic capacitor across the second picture i-f cathode resistor (pin 2 of *V102* to ground). Use the shortest possible leads.

7. Realign the picture i-f amplifier using the following peak frequencies:

a. Second picture i-f transformer (*T102* all models)—22.5 mc.

b. Third picture i-f transformer (*T103* all models)—21.95 mc.

c. Fourth picture i-f transformer (*T104* all models)—25.3 mc.

d. Fifth picture i-f coil (*L103* in 17- and 19-inch models, *L102* in 14-inch models)—23.7 mc.

8. Sweep-align the picture i-f amplifier to obtain the same overall response as shown in the service data.

It is recommended that 6 volts of negative bias be applied to the picture i-f bias bus circuit during alignment.

RCA VICTOR Models 6T53,
-54, -64, -65, -71, -74,
-75, -76, -84, -86, -87,
9T57, -77, -79, -89

Increased sound and picture gain on weak signals.

The following changes, which have been incorporated in production, are suggested where necessary to provide additional sound and picture gain on very weak signals:

1. Change the first and second picture i-f cathode resistors (*R104* and *R108* in 12½-inch models, *R103* and *R107* in 16- and 19-inch models) from 120 ohms to 82 ohms. This provides additional gain through these stages.

2. Move the point of sound take-off (connection C) on the trap of *T103* up two turns on the coil. This provides additional 21-mc sound voltage to the sound i-f amplifier.

3. After the above changes, it will be necessary to realign the sound and picture i-f amplifiers accurately.

RCA VICTOR Models 6T53,
-54, -64, -65, -71, -74,
-75, -76, -84, -86, -87,
9T57, -77, -79, -89

Agc control switch.

The agc switch used in these chassis is a 4-contact, 3-position rotary type. It is very similar to that used in the earlier production of the above receivers, the difference being that the new rotor is longer, and contacts terminal 4 when the switch is in the center (No. 2) position. In addition, the leads to terminals 3 and 4 are reversed.

The correct setting for the agc switch can be determined as follows:

1. Position No. 1 (counterclockwise when viewed from rear)—max-

imum agc voltage is used in this position. It is the correct position for strong signals.

2. Position No. 2 (center)—in this position, the rotor contacts terminals 1, 2, and 4 of the agc switch. This reduces the agc voltage and changes the time constant of the agc system to allow quicker recovery of the agc from any tendency to "set up" on noise. In addition, improved noise immunity results from the change in cathode resistance of the d-c restorer. This position of the agc switch should be used when receiving medium to weak signals.

3. Position No. 3 (clockwise)—in this position, the agc voltage is completely shorted out. The receiver operates at maximum gain and maximum noise immunity. This position should only be used on very weak signals.

RCA VICTOR Models 6T53,
-54, -64, -65, -71, -75,
-76, 7T103, -104, -111,
-112, -122, -123, -124,
-132, 9T89, -147, 16T152

Weak or poor sound.

When investigating the causes of weak or poor sound, do not overlook the possibility of defective 94- μmf capacitors contained within the sound-discriminator transformer.

Also, check for loose slug adjustments in this transformer. Vibration over a period of time can cause detuning through physical movement of the slugs. If any loose slugs are encountered, the adjusting screw may be lightly cemented after proper alignment.

Poor or weak sound can result from leakage, opening, or shorting of capacitors C168 and C190 in

12 $\frac{1}{2}$ -inch models, and capacitors C171, and C172 (1,500- μmf screen-grid bypass capacitors in 2nd sound i-f amplifier) in 16-inch and 19-inch models.

RCA VICTOR Models 6T53,
-54, -64, -65, -71, -75,
-76, 7T103, -104, -111,
-112, -122, -123, -124,
-132, 9T89, -147, 16T152

Increasing sync stability in low-signal, high-noise areas (see Fig. 6).

Part (A) of the figure shows the conventional 16-inch and 19-inch table model and console (chassis KCS47) sync separator, d-c restorer, sync amplifier and vertical-oscillator circuits. Part (B) of the figure shows the schematic of the same circuits of the 16-inch and 19-inch combination instruments (chassis KCS60).

Part (C) of the figure shows the modified sync, d-c restorer, and vertical-oscillator circuits, which are the same for both straight television instruments and combinations. When these modifications are made, the sync stability is increased in low-signal strength, high-noise areas.

Comparing part (A) with part (C), it will be noted that V107, which was originally used as a d-c restorer, sync separator and amplifier, is reconnected with the first half of the tube as d-c restorer and horizontal-sync separator, and with the second half connected as a vertical-sync separator. V108, which was a 6J5 type used as a vertical-sweep oscillator and discharge tube, is replaced by a 6SN7 type, half of which is used as the vertical-sweep oscillator and discharge tube, while the

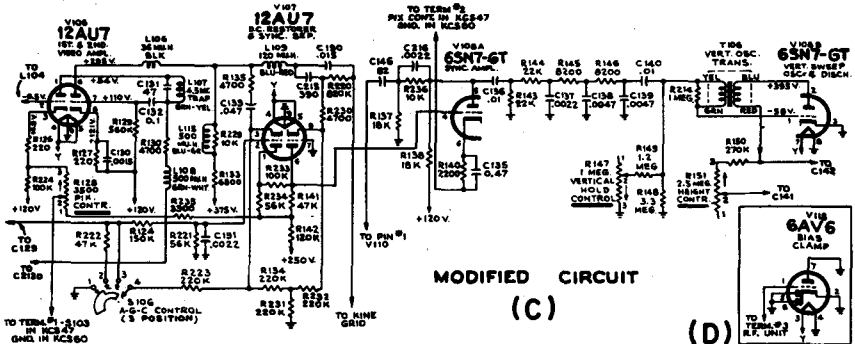
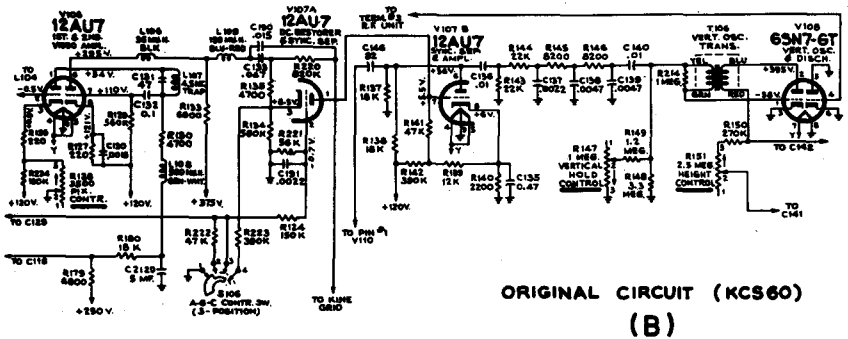
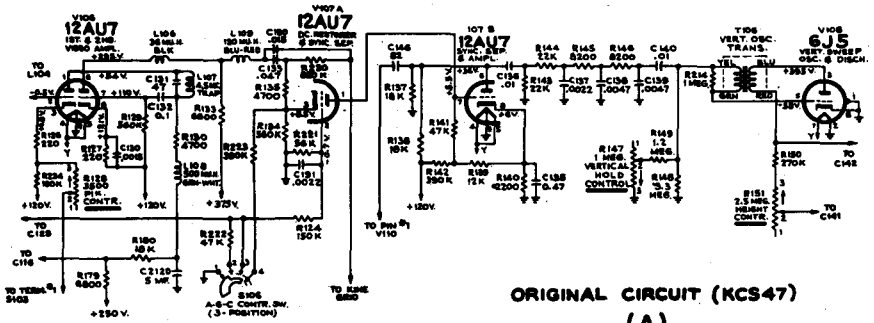

Fig. 6 - RCA Victor

remaining half is used as a sync amplifier.

If the changes covered by these schematics are warranted, the parts shown in the table are required:

The additional tube and socket are required in the 16-inch and 19-inch combination models since the por-

tion of the 6SN7 tube V108 which was formerly used as a bias-clamp is reconnected as a sync amplifier, and it is necessary to install a separate bias-clamp tube. The connections for the additional bias-clamp are shown in part (D) of the figure. Although type 6AV6 is recommend-

Quantity	Stock No.	Symbol	Description
1*	6SN7	V108	Tube
1**	6AV6	V118	Tube
1	30733	R235	3,300-ohm resistor, 1/2 watt
1	30494	R230	4,700-ohm resistor, 1/2 watt
2	3078	R229, R236	10-k resistor, 1/2 watt
1	30650	R234	56-k resistor, 1/2 watt
1	3252	R233	100-k resistor, 1/2 watt
1	30180	R142	120-k resistor, 1/2 watt
4	14583	R134, R223, R231, R232	220-k resistor, 1/2 watt
1	73094	C215	390- μ f mica capacitor
1	73595	C216	.0022- μ f capacitor
1	75252	L115	550- μ h peaking coil
1	76010	S106	agc switch
1**	73117	—	7-pin miniature tube socket
1	—	—	4-lug terminal strip
1	—	—	1-lug terminal strip

* This part not required for combination instruments.

** Only required in combination models.

ed for this bias-clamp application, any of the following tubes may be used with the same socket connections: 6BA6, 6BF6, 6AT6, 6AQ6, 6AK6, 6AR5, 6AG5, 6AU6, 6BJ6, or 6CB6. The additional tube can be installed in the existing hole near the center of the chassis.

RCA VICTOR Models 6T53,
-54, -64, -65, -71, -74,
-75, -76, 9T89, -147,
16T152

Picture bending.

Under certain critical signal conditions a bending may occur in the picture which may be corrected by the following suggestions:

1. Resistor *R134* (connected to cathode of d-c restorer), which originally was 470 k, was changed in production to 820 k, and now has been standardized at 560 k.

2. *R142* (voltage-divider resistor supplying grid voltage to the sync amplifier from the 250-volt bus) may

be changed to 390 k, and connected to +120 volts instead of +250 volts.

Certain conditions of intermittent picture bending can result from improper ground connections to *R8* (cathode resistor of r-f amplifier), pins 3 and 7 of *V2* (r-f amplifier), and the base of *V2* tube shield.

RCA VICTOR Models 6T72,
T164, TA128, -129, -169,
TC124, -125, -127, -165
through -168

Weak-signal area operation.

Since the vast majority of receivers are sold in strong-signal areas, the chassis are aligned to produce the cleanest picture in those areas. However, if the receiver is to be operated in a weak-signal area, better performance can be obtained by peaking the r-f unit.

To peak the r-f unit in these receivers, disconnect *R14*, the 390-ohm resistor (input circuit to r-f amplifier which is on top of the r-f unit

chassis). Adjust *L66* (low-band centering adjustment in r-f amplifier grid circuit) to obtain the best possible picture on the weakest low-channel station received. By this action, the r-f gain is increased 50 percent at the expense of r-f bandwidth and an improvement in the weak-signal picture results.

If the peaked receiver is subsequently taken to a strong-signal area, the resistor *R14* should be connected in place and *L66* adjusted for flat response on the low channels.

RCA VICTOR Models 7T103,
17T153, -154, -155, -160,
-162, -172, -173, -174

Replacement of deflection yokes.

In production, yoke stock No. 74952 was used for magnetic focused model 7T103 and electrostatic focused model 7T103B receivers. Likewise, in production, yoke stock No. 76616 was employed for electrostatic focused model 17T153 and magnetic focused 17T172K and 17T150 series receivers.

Magnetic focus causes the picture to be rotated about 5 degrees from the position which the same yoke would produce on an electrostatic focused picture tube. This rotation of the picture can be corrected by rotating the yoke around the neck of the picture tube in the proper direction. However, only a limited range of adjustment is provided by the wing screw on the yoke.

In production, the yoke was positioned within the retaining strap so that the picture was straight when the wing-screw adjustment was in the center of its range. Naturally this yoke position varied depending on

whether the yoke was to be used with a magnetic or electrostatic focused picture tube.

The yokes stocked by the manufacturer may have been adjusted for either electrostatic or magnetic focused picture tubes depending on which was in production of the time of ordering. In the event of yoke failure, when the yoke is replaced, it may be necessary to adjust the yoke within its strap in order to straighten the picture.

RCA VICTOR Model 8T241,
-243, -244

Modifications for remote-area operation.

1. Check to see that the receiver antenna transformer *T115* is connected properly and that no windings are open.

2. Remove 8T241 r-f unit and change *R11* grid resistor of r-f amplifier to 10,000 ohms.

3. If the receiver is to work in weak-signal areas and never to receive a strong signal, then maximum r-f gain can be obtained by installing a small bleeder just to supply —0.5 volts for the r-f amplifier grid. *R12* (150-ohm resistor in grid circuit of r-f amplifier) should be disconnected from its present position and reconnected to this —0.5 volt point.

4. Check oscillator injection into mixer. This should read at least —2.5 volts on all channels when measured by a VTVM at test connection *R13*. If this is not achieved, adjust the link between *L2* (oscillator) and *L3* (mixer grid) until such injection is obtained.

5. Realign r-f unit for peak performance on the channels to be received.

6. Change *RI02* (cathode resistor of 1st video i-f amplifier) to 68 ohms. Realign the picture i-f amplifier making sure that the high-frequency slope of the response curve is as broad as specified in the service data. If receiver is to be operated in a very weak signal area, place the picture carrier at 60 percent, or even 80 percent on the slope. Check to see that the receiver retains proper response at low signal-input levels, and -1.0 volts i-f bias. Some change in response is normal but the picture carrier should remain high on the curve. This alignment causes the picture to be smeared on strong signals but produces the best pictures on signals of less than 100 microvolts.

7. Make sure that the a-c line feeding the receiver is at least 115 volts at all times, as this radically effects the picture tube anode voltage. If the horizontal-deflection system is operating improperly or is incorrectly adjusted, there may be insufficient high voltage on the picture tube. When a "snow flake" occurs, this causes the tube to bloom, thus making the snow more pronounced. Make sure that all +B voltages are normal, especially the 6BG6 screen. Change *RI81* (grid resistor of horizontal-output tube) to 150 k. Adjust the drive trimmer as far counterclockwise as possible. It should be possible to have at least 9,000 volts on the picture tube at this point.

8. Adjust the focus coil carefully so as to obtain best focus in white areas of the picture.

9. Modify the video amplifier to saturate on whites, thus reducing the prominence of the "snow." Discon-

nect *RI24* (12-k resistor in cathode circuit of 2nd video amplifier) from the -120 volt bus and return it to ground. This causes adjustment of the picture control to affect brightness, however, once set, these adjustments can be left alone.

10. Adjust the agc threshold control counterclockwise from the normal position to provide the best signal-to-noise (snow) condition. Unfortunately, this makes the sync more susceptible to impulse-type interference such as ignition, etc.

11. Cut the antenna transmission line length to provide maximum signal. This effect is most noticeable on the high channels.

12. In general, use the highest gain antenna array that can be had, place it as high in the air as possible and above all surrounding obstacles, especially power lines. In some cases, however, if the electric field is distorted, a simple antenna may produce more signal than an elaborate array, and the height may become critical. In selecting an antenna for gain, make sure that high gain occurs on the channel or channels to be received. Some antennas, in order to reduce size, cut off badly on channel 2, and on some, the response is slightly down even on channel 3. In general, the best antenna or array for any particular channel is one cut for that channel.

13. Unless bothered with an extremely high noise level (ignition, etc.) the antenna transmission line should be the 300-ohm open type. Coax and twinex have higher losses than the open line, which in weak-signal areas cannot be tolerated. In time, however, open-wire line may foul up and have to be replaced. This

fouling shows up as a loss of signal in wet weather.

Note: The above modifications make these receivers so "hot" that a booster is not likely to be of help in the receiving of weak signals.

RCA VICTOR Models 8T270,
9T246, 9T270, 9TC245,
T100, -120, -121, -164,
TA128, -129, -169, TC124

Bias adjustment for picture i-f alignment.

Some question has arisen regarding the bias adjustment alignment of the picture i-f since the change in the 3rd picture i-f bias.

In order to clear up any misunderstanding regarding the bias setting and point of measuring this bias, the following is correct:

1. In receivers using all 6AG5 tubes in the picture i-f system, adjust bias with potentiometer to read -4.5 volts measured at junction of *R135* (39-k resistor connected to the plate of the agc amplifier) and *R136* (6,800-ohm resistor connected between *R135* and ground).

2. In receivers using the 6BA6 1st and 3rd picture i-f system and having the 3rd picture i-f bias connected to the r-f bias bus, adjust bias with potentiometer to read -12 volts measured at junction of *R135* and *C190* (.47- μ f capacitor connected from plate of agc amplifier to ground).

3. In receivers using the 6BA6 1st and 3rd picture i-f system and having the 3rd picture i-f bias connected to junction of *R135* and *C190*, adjust bias with potentiometer to read -6.5 volts measured at junction of *R135* and *C190*.

RCA VICTOR Models 8T270,
9T246, 9T270, 9TC245,
T100, -120, -121, -164,
TA128, -129, -169, TC124

Buzz in sound.

A 60-cycle buzz appeared in the sound of some of the above receivers when operated in strong-signal areas. There are several modifications which will cure this difficulty, some of which have already been made in the production of some of the above models.

For receivers using all 6AG5 tubes in picture i-f stages:

1. Replace 6AG5 tube in first picture i-f with others until one is found to cure condition. (Note: 6AG5 tubes which have an abnormally sharp grid cut-off characteristic will cause a buzz in sound. A tube removed for this trouble is not necessarily defective, but can be used in either the 2nd or 4th picture i-f where fixed bias is applied.)

2. Ground test connection in r-f unit (*R13*, 100 k).

3. Check all filter capacitors in the agc circuit for wrong connections and also see that they are in good working condition.

For receivers using 6BA6 tubes in 1st and 3rd picture i-f stages:

1. Change 3rd picture i-f tube bias. Disconnect *R110* (8,200-ohm resistor in grid circuit of 3rd picture i-f tube), *L119* (36- μ h peaking coil across *R110*) and *C113* (1,500- μ mf capacitor) from their present tie point at the junction of *R135* (56-k resistor connected to plate of agc amplifier) and *C190* (.47- μ f capacitor connected to plate of agc amplifier) and reconnect them to the adjacent tie point of the junction of

C133 (.47- μ f capacitor on other side of *R135*) and *R136* (6,800 to 12-k resistor to ground in plate circuit of agc amplifier).

Note: A greater agc control of the r-f stage and 1st picture i-f amplifier is obtained by this change. In fringe areas, slight reduction in sound may be encountered with this bias change. However, picture sensitivity will not be affected.

2. Ground test connection (*R13*, 100 k) in r-f unit.

3. Change *R136* from 6,800 ohms to 10 k.

4. Check all filter capacitors in agc circuit for correct connection and also to see if they are in good working condition.

RCA VICTOR Model 9T57,
-77, -79, -89

Corona interference.

An interference pattern consisting of narrow vertical bars at the left-hand side of the raster may be the result of internal corona, or arcing, within the 4.7- μ f capacitor (*C198*) located in the plate circuit of the horizontal-sweep output tube.

This interference may be mistaken for Barkhausen oscillation, but none of the normal Barkhausen preventative methods such as adjusting the drive, placing a magnet over the 6BG6, etc., will be effective in eliminating the interference.

If such a condition is encountered, the capacitor should be replaced.

RCA VICTOR Models 9T246,
9TC245, T121

Improper response from T1 and T101.

In some cases, in the above listed receivers, it was found diffi-

cult to obtain proper response from *T1* and *T101* (converter transformer and 1st picture i-f transformer) during alignment. The difficulties are usually caused by reversed slugs in *T101*. The trap (top) slug should be between $\frac{5}{8}$ and 1 inch in length (depending on the vendor) and the input (bottom) slug should be about $\frac{1}{2}$ inch long. On some sets the two slugs might have been switched around. This will not permit sufficient adjustment on the over-coupled tuning. Both slugs may be removed for examination from the top of the transformer. The short slug should be put in first in reassembly.

RCA VICTOR Models 9TC245,
9TC247, -249, T121

Poor vertical sync.

Reports from the field show that in a few cases poor vertical sync has been caused by capacitor *C136* (.22- μ f cathode bypass for 1st sync separator *V108*). In some cases this capacitor had broken loose from ground.

Some vertical-oscillator transformers marked 274011 with too high Q caused a white condition at the top of the picture and possible instability of sync. The cure was to lower the transformer Q by connecting a 1-meg resistor across the green and yellow transformer leads.

RCA VICTOR Models 9TC245,
9TC247, -249, T121

Unstable horizontal sync.

It has been reported from the field, that in a few cases unstable horizontal sync (wavy picture) is caused by the wrong values of *C135* (connected to pin 6 of the agc rec-

tifier), R144 (connected to pin 5 of the age rectifier), and R217 (voltage-divider resistor in -60 volt bus supplying cathode voltage for age rectifier).

Part	Correct Value
C135	.01 μ f
R144	4700 ohm
R217	2700 ohm

RCA VICTOR Models 9TC247,
-249

Cracking of wood masks.

In some instances the wood picture-tube mask (stock No. 74754) in these sets has cracked. Because of this, a newer mask (made of Masonite), which will not split, has been made available for replacement. The newer mask (Masonite) is available as stock No. 74808.

RCA VICTOR Models 9TW390,
S1000

Increasing range of brightness control.

To increase the range of operation of the brightness control on these receivers, R222 (connected to one side of the brightness control) was changed from 47 k to 39 k. If these receivers exhibit insufficient brightness, this change can be made in the field.

RCA VICTOR Model 9TW390
Preventing heater-choke burnout (see Fig. 7).

A .05- μ f capacitor, designated C389 was added between terminal 8 of function switch S304 (front) and tuning capacitor C303/C304 in radio chassis RC617A.

Early production models of the receiver will not have this capacitor in the radio chassis.

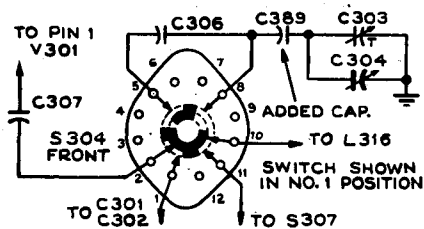

Fig. 7 — RCA Victor

When the radio-function switch is in the TV position, the filament voltage is present on the high side of the tuning capacitor (C303/C304) due to the function switch design. Any shorting of the tuning capacitors to ground causes L314 (filament choke) to burn out. The insertion of the capacitor removes filament voltage from the tuning capacitor without affecting its operation.

RCA VICTOR Models 16T53,
-54, -64, -65, -71, -74,
-75, -76, -84, -86, -87,
9T57, -77, -79, -89

Picture smear.

Smear is generally interpreted as an extension or washing out of white or black trailing edges so that the trailing edge is not sharply defined, but is smeared out toward the right side of the screen. This type of smear may result from incorrect:

1. R-f unit response in the receiver.
2. I-f amplifier response in the receiver.
3. Overall r.f.-i.f. amplifier response in the receiver.
4. High-frequency response in the video amplifier in the receiver.
5. High-frequency response in station transmission.
6. High-frequency response due to relayed or cabled transmission.

If smear is encountered, the initial step in correction is to make certain that the r-f and i-f alignment is correct as indicated in service data. Particular care should be taken to have the 26.25-mc, 25.50-mc, and 24.75-mc markers at the proper location on the overall rf-if response curve.

Additional peaking of the high video frequencies can be obtained in the video amplifier by the following:

1. Add 1,500- μ f capacitor across *R126* (220-ohm resistor in cathode circuit of first video amplifier).

2. Add 100- μ f capacitor from the junction of *R126* and *R224* (100-k resistor connected to +120 volts) to ground.

3. Change *L105* (grid circuit of first video amplifier) from 120 μ h to 500 μ h (stock No. 75252).

4. Capacitors *C190*, *C132*, and *C133* should be dressed away from each other to reduce coupling. *C190* is a .047- μ f coupling capacitor to grid of the picture tube; *C132* is a .1- μ f coupling capacitor to the grid of the 2nd video amplifier; and *C133* is a .047- μ f coupling capacitor to the cathode, pin 3, of the d-c restorer.

RCA VICTOR Models 17T150,
-151, -153, -154, -155,
-160, -162, -163, -172,
-172K, -173, -173K, -174,
-174K, 21T159, -165,
-176, -177, -178, -179

Agc threshold control adjustment.

The agc control is adjusted at the factory to provide maximum possible gain without clipping sync for all signals above the receiver thresh-

old up to 25,000 microvolts. The adjustment of this control should not be touched in the field unless it is definitely known to be incorrect. If the control is misadjusted so as to increase the receiver gain, it may overload when a strong signal is received or when a weak signal temporarily increases in strength due to unusual propagation conditions. On the other hand, if the receiver gain is lowered by the agc control, the sync noise immunity is reduced.

In order to reduce the prominence of snow on weak signals it is important that the picture control not be operated at its maximum clockwise position. Such an adjustment will provide a higher contrast picture but at the same time may produce an apparent poorer signal-to-noise ratio due to the fact that an excessive amount of signal on the kinescope grid causes the snow to bloom or defocus, thus causing the flake particle to become larger and more prominent than normal. At the same time it is equally important that the receiver be focused to obtain the appearance of the least amount of snow in the picture. To do this, focus the receiver by the method described in the service data. As a final adjustment, adjust the focus control for the appearance of minimum snow in the picture.

Only under two conditions can it be considered permissible to adjust the agc control. In an area where the signal is so weak that the snow practically obscures the picture after having taken all the above precautions, then the agc control may be adjusted to give the best signal-to-noise ratio. It should be recog-

nized, however, that trouble from loss of sync noise immunity might be experienced.

The other condition which would justify adjustment of the agc control is where a signal of over 25,000 microvolts is received. Under this condition the agc control should be adjusted until the receiver no longer overloads.

RCA VICTOR Models 17T150,
-151, -153, -154, -155,
-160, -162, -163, -172,
-172K, -173, -173K, -174,
-174K, 21T159, -165,
-176, -177, -178, -179

Replacement of crystal detector.

Several different types and makes of crystals are used, such as 1N60, 1N64, and CK706. These crystals have slightly different characteristics and may not be directly interchangeable. In production, these differences are taken care of by varying the value of *R154* (primary shunt resistor) which is located in *T109* (5th picture i-f transformer). This resistor is normally 10 k. However, to take care of different crystals, this resistor may vary from 5,600 ohms to 10k ohms.

If the crystal is to be replaced, it should be replaced by one of the same make and type. However, if desired, the entire *T109* transformer and matching resistor may be installed. In any event, if *T109* or *CR101* (crystal) is replaced, the overall response should be checked.

If a crystal is replaced, care should be taken to get it connected in the proper polarity. Since germanium crystals are marked differently than selenium rectifiers, confusion may re-

sult. Selenium rectifiers are marked + and - to show the polarity of the d-c output voltage. Germanium crystals are marked to show the polarity of voltage that must be applied to obtain maximum current flow. The cathode end of a germanium crystal may be coded with green paint or marked -. The anode end may not be coded or may be coded +. In schematic symbols, the anode is shown as an arrowhead and the cathode as a flat bar. In *T109*, the anode (+) end is connected to terminal A and the cathode (-) end to terminal D. Care should also be taken not to overheat the crystal with the soldering iron as damage to the crystal may result.

As a protection against damage to the crystal detector, a 220-ohm, 1/2-watt resistor has been added in series with the screen of *V110*, the 6AG7 video amplifier. This resistor is designated as *R174* in both 17- and 21-inch receivers and is carried under stock number 503122.

RCA VICTOR Models 17T150,
-151, -153, -154, -155,
-160, -162, -163, -172,
-172K, -173, -173K, -174,
-174K, 21T159, -165,
-176, -177, -178, -179

Oscillator switch wafer overheating.

Some tuner switches have a wax-treated oscillator wafer. Heat, due to soldering operations, melts the wax and loosens the switch terminals on which the inductances are mounted. Operation of the switch causes variations in inductance during switching operations. Tuning will vary, depending on the direction of

approach of the channel-selector switch. This is the result of compression and expansion of the coils mounted on the loose switch contacts. Therefore, when repairing r-f units, take care not to overheat the oscillator switch wafer. If the wafer is thus damaged, replacement of the wafer is the most practical solution.

RCA VICTOR Models 17T150, -151, -153, -154, -155, -160, -162, -163, -172, -172K, -173, -173K, -174, -174K, 21T159, -165, -176, -177, -178, -179

Separation of sound and picture in weak-signal areas (see Fig. 8).

Normally the picture carrier falls at 50 percent on the slope of the overall response curve as shown. When receiving signals of less than 50 microvolts on intercarrier receivers,

it is common practice to adjust the fine-tuning control so as to move the picture carrier up the slope to improve the signal-to-noise ratio. The actual amount that the carrier is moved depends upon the signal strength. On extremely weak signals, the picture carrier may be moved as high as 80 to 90 percent on the slope of the curve. This may represent a change of as much as 75 megacycles of all frequencies being passed through the picture i-f amplifier. Under such conditions the sound may become weak and noisy even on intercarrier receivers. The reason for this is shown in the figure.

When the picture carrier is rolled up the slope and lowered in frequency by .75 mc, the sound carrier is also lowered in frequency by .75 mc to become 40.50 mc. As can be seen by the enlarged section of the response curve, the sound carrier begins to fall into the adjacent channel picture trap with a consequent reduction of sound output. Receiver designs which do not incorporate an adjacent channel picture trap may avoid this difficulty at the expense of adjacent channel picture rejection.

It is possible to overcome the above described difficulty in many cases by a simple adjustment which can be made in the field without the aid of test equipment. When the picture carrier is rolled up the slope by .75 mc, the adjacent channel picture carrier is lowered in frequency to 39.00 mc and no longer falls into the adjacent channel picture trap. If the trap is returned to 39.00 mc, it will permit the response at 40.50 mc to rise somewhat, produce stronger sound, and will produce greater adjacent channel picture rejection un-

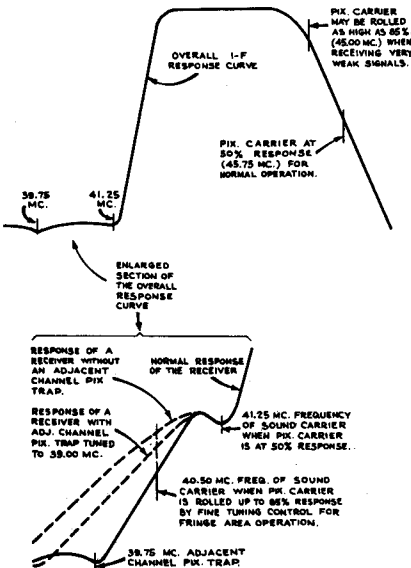

Fig. 8 — RCA Victor

der the actual operating condition. If a strong signal is available on another channel and the fine tuning is adjusted to roll the picture carrier down the slope to the normal 50-percent point, the adjacent channel picture trap will appear mistuned. However, it is not likely that adjacent channel picture interference will be experienced on strong signals.

In addition to the above adjustment, *T107* (3rd picture i-f transformer), normally peaked at 41.8 mc, may be lowered in frequency to provide improved sound gain. Care should be taken in making this adjustment not to lower its frequency any more than necessary as it reduces adjacent channel picture rejection somewhat and might cause difficulty from sound in the picture if a strong signal is available on another channel.

The above adjustments may be made without removing the chassis from the cabinet. First, tune in the desired channel and adjust the fine-tuning control for best picture. Then, since the adjacent channel picture trap is under the picture tube, disconnect the high-voltage lead at the chassis to prevent getting a shock. Turn the *T104* (1st picture i-f transformer) top core clockwise, approximately $\frac{1}{2}$ turn if it is a threaded-core type or approximately $1\frac{1}{2}$ turns clockwise if it employs a brass stud extending from the transformer shield. Restore the picture tube high voltage connection. Then, from the top of the chassis, adjust *T107* clockwise $\frac{1}{2}$ turn or less.

If adjacent channel picture interference is a severe problem, it may be necessary to remove the chassis from the cabinet and adjust *T104*

top core while observing the picture for minimum interference.

RCA VICTOR Models 17T150,
-151, -153, -154, -155,
-160, -162, -163, -172,
-173, -174, 21T159, -165,
-176, -177, -178, -179

Fuse replacement (see Fig. 9).

A new fuse, replacing *F101*, has been incorporated in both the 17-inch and 21-inch television receivers. It is a slow-blow type and is intended to reduce fuse blowing due to surges. The new fuse is rated at 0.2 ampere and is carried under stock No. 76801. It can be readily identified by the small spring enclosed at one end.

Most early production 17-inch receivers have a 2-watt wire-wound resistor (*R234*) in the cathode circuit of the 6BQ6GT, *V117*. Such receivers will need no modification if the slow-blow fuse is installed in the field. A few 17-inch receivers have composition-type resistors in the cathode circuit. If a slow-blow fuse is installed in such a receiver, the composition resistor should be replaced with a 180-ohm, 2-watt, wire-wound type, stock No. 76639.

All early production 21-inch receivers employed a composition type resistor (*R234*) in the 6CD6G, *V117*, cathode circuit. If a slow-blow fuse is installed in one of these receivers, the composition resistor should be replaced by a 100-ohm, 2-watt, wire-wound resistor, stock No. 74015. Late production receivers employ the wire-wound resistor.

In a few 21-inch receivers, the slow-blow fuse has been known to fail due to a-c from the sweep circuit flowing through *F101*. To elim-

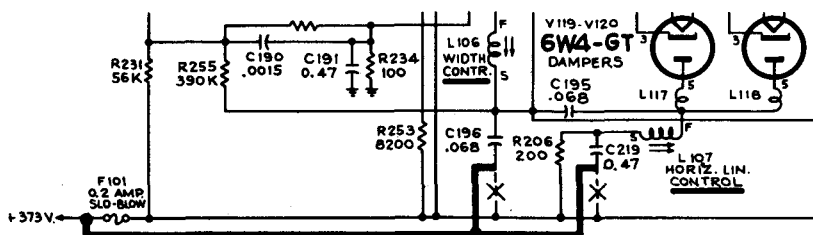

Fig. 9 — RCA Victor

inate this difficulty the factory has made a wiring change. *C196* (.068 μ f) and *C219* (.047 μ f) were changed from their original connection and reconnected to the +373 volt bus side of the fuse as shown in the partial schematic diagram.

As a field-service convenience, if a slow-blow type fuse fails in an unmodified 21-inch receiver, it should be replaced by a quick-blow type (stock No. 73600). However, if an unmodified receiver is brought into the shop for service, *C196* and *C219* should be reconnected and a slow-blow fuse installed.

RCA VICTOR Models 17T150,
-151, -153, -154, -155,
-160, -162, -172, -173,
-174

Replacement of h-v rectifier.

In some of the above chassis, terminal 5 of the 1B3GT socket has been used as a tie point. It has been found that some brands of tubes have an internal connection in the tube between pins 5 and 7. Such tubes will not operate in chassis which are wired as noted above.

When replacing the 1B3GT tube in the field, the serviceman may employ one of the three following methods to avoid difficulty:

1. Use a tube which does not employ a connection between pins 5 and 7. RCA tubes do not have this connection.
2. Rewire the 1B3GT tube socket so that terminal 4 is employed as the tie point instead of terminal 5.
3. If the tube has a connection between pins 5 and 7, clip pin 5 off of the tube base.

RCA VICTOR Models 17T153,
-154, -155, -160, -162,
-172, -173, -174, 21T176,
-177, -178, -179

Picture i-f transformer adjustments (see Fig. 10).

When sweep aligning *T105* (1st picture i-f plate transformer) and *T106* (2nd picture i-f grid transformer), care must be taken not to short out the grid bias with the sweep-output cable. Be sure to insert a 1,000- μ f ceramic capacitor between the sweep-output cable and grid of *V106* (1st picture i-f amplifier).

It has been found desirable to align *T1* (converter transformer) and *T104* (1st picture i-f grid transformer) to the response shown in part (B) of the figure rather than as it appears in the service data (see part A).

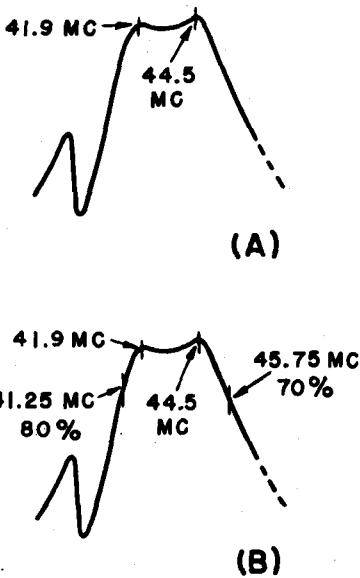

Fig. 10 — RCA Victor

RCA VICTOR Models 17T153,
 -154, -155, -160, -162,
 -172, -173, -174, 21T176,
 -177, -178, -179

R-f and i-f bias ratios
 (see Fig. 11).

In medium field strength areas an occasional receiver may show some snow on signals in the 300 to 1,000 microvolt signal range due to an improper ratio of r-f and i-f bias. If the r-f bias is high with respect to the i-f bias, the picture becomes snowy. If the i-f bias is too high with respect to r-f bias, the receiver may overload on strong signals.

To determine whether or not the biases are of the correct ratio, tune in a signal and measure the r-f bias, the i-f bias, and the agc amplifier plate voltage with a VTVM. The signal must be steady during these measurements. Plot these points on the accompanying graph. The values should fall within the range of the dotted lines.

According to the graph, when the agc amplifier plate measures -45 volts, the i-f bias should be -8.2 volts. If the i-f bias actually measured -10 volts, it indicates that *R143* (68-k resistor in i-f agc bus) or *R145* (150-k resistor connected to plate of agc amplifier) is too low

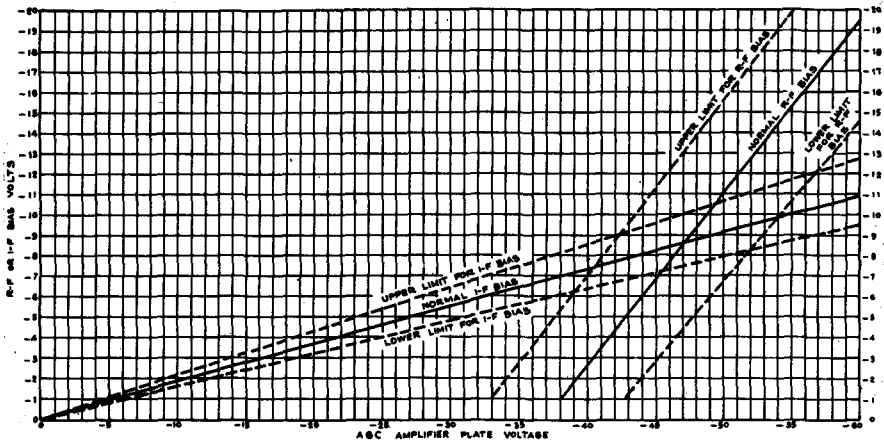

Fig. 11 — RCA Victor

in value and/or *R144* or *R150* (82-k and 150-k resistors connected to ground in the i-f agc bus) is too high. If, however, the i-f bias actually measured —6 volts, it indicates *R143* or *R145* is too high in value and/or *R144* or *R150* is too low. The resistors originally employed in production were 10 percent tolerance units. However, if *R143* and *R145* are at one limit of their tolerance and *R144* and *R150* are at the other limit of their tolerance, a considerable error in i-f bias is produced.

Similarly at —45 volts agc amplifier plate voltage, the r-f bias should measure —6.8 volts. If the r-f bias should measure say —12 volts, it indicates that *R128* or *R129* (68-k and 100-k resistors in plate circuit of agc amplifier) is too low or *R127* (680-k resistor in plate circuit in agc amplifier) is too high or the 143-volt bus is too low. If the bias is too low, obviously the converse is true.

In several instances, r-f or i-f bias difficulties have been traced to leaky electrolytic capacitors *C124* or *C138* (both 2- μ f capacitors in the agc i-f bias). In two known instances, one of these two capacitors was connected into the circuit in reversed polarity due to a reversal of the polarity markings on the capacitor.

The above agc bias circuit description is for the 17T153 series receivers. The 21T176 receivers are similar except for slight differences which cause the biases to occur at slightly different agc plate voltages.

RCA VICTOR Models 17T153,
 -154, -155, -160, -162,
 -172, -173, -174, 21T176,
 -177, -178, -179

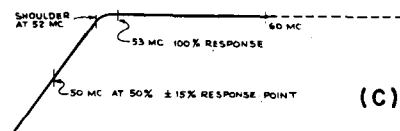
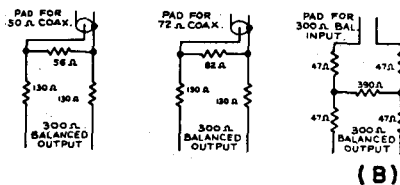
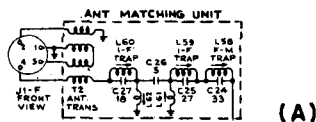

Fig. 12 — RCA Victor

Alignment of antenna-matching unit with low-output signal generator (see Fig. 12).

The alignment procedure for the antenna-matching unit as given in the service data calls for a signal generator with an output in the order of 1.0 volt. In order to permit the use of generators with less output, the following procedure is given:

1. Disconnect the lead from the f-m trap *L58* to the channel-selector switch *S5*.
2. With a short jumper, connect the output of the matching unit through a 1,000- μ f capacitor to the grid of the second picture i-f amplifier, pin 1 of *V107*.
3. Replace the cover on the matching unit while making all adjustments.
4. Remove the first picture i-f amplifier tube *V106*.
5. Connect the positive terminal of a bias box to the chassis and the potentiometer arm to the junction of *R143* and *R144* (i-f agc bus). Set

the potentiometer to produce approximately —6.0 volts of bias at the test point *TP101* (in grid circuit of 2nd i-f amplifier).

6. Connect an oscilloscope to the video-test point *TP102* (in grid circuit of video amplifier) and set the oscilloscope gain to maximum.

7. Connect a signal generator to the antenna-input terminals. Modulate the signal generator 30 percent with an audio signal.

8. Tune the signal generator to 45.75 mc, and adjust the generator output to give an indication on the oscilloscope. Adjust *L59* (i-f trap) in the antenna-matching unit for minimum audio indication on the oscilloscope.

9. Tune the signal generator to 41.25 mc, and adjust *L60* (i-f trap connected to antenna transformer) for minimum audio indication on the oscilloscope.

10. Remove the jumper from the output of the matching unit.

11. Connect a 300-ohm, 1/2-watt composition resistor from *L58* (f-m trap) to ground, keeping the leads as short as possible.

12. Connect an oscilloscope low capacitance crystal probe from *L58* to ground. The sensitivity of the oscilloscope should be approximately 0.03 volt per inch. Set the oscilloscope gain to maximum.

13. Connect the r-f sweep generator to the matching unit antenna-input terminals. In order to prevent coupling reactance from the sweep generator into the matching unit, it is advisable to employ a resistance pad at the matching-unit terminals. Part (B) of the figure shows three different resistance pads for use with sweep generators with 50-ohm coax

output, 72-ohm coax output, or 300-ohm balanced output. Choose the pad to match the output impedance of the particular sweep generator employed.

14. Connect the signal generator loosely to the matching unit antenna terminals.

15. Set the sweep generator to sweep from 45 mc to 54 mc.

16. Adjust *L61* and *L62* (see part A of figure) to obtain the response shown in part (C) of the illustration. *L61* is most effective in locating the position of the shoulder of the curve at 52 mc, and *L62* should be adjusted to give maximum amplitude at 53 mc and above, consistent with the specified shape of the response curve. The adjustments in the matching unit interact to some extent. Repeat the above procedure until no further adjustments are necessary.

17. Remove the 300-ohm resistor and crystal probe connections. Restore the connection between *L58* and *S5*. Replace *V106*.

RCA VICTOR Models 17T153,
-154, -155, -160, -162,
-172, -173, -174

Unstable vertical sync and hold.

In a few cases it has been found that *C172* (.0022- μ f capacitor connected in the circuit between the grid of the vertical oscillator and the plate of the vertical-output tube) has changed value with time and temperature, requiring resetting the vertical-hold control during initial warm-up and causing the control to be operated at the extreme clockwise position. If such a condition is encountered, replace *C172* with another capacitor which will permit normal operation of the control.

Several cases have been reported from the field in which *R191* (47,000-ohm voltage-divider resistor which supplies 100 volts to the cathode, pin 6, of the sync separator from the 265-volt bus) was connected to the cathode side of *R266* (1.8-meg series resistor to cathode, pin 6, of sync separator) instead of the junction of *R265* (47-k voltage-divider resistor in same circuit as *R266*) and *R266*. This results in 70 to 80 volts on the cathode pin 6 of *V113* instead of the normal 100 volts, causing unstable vertical sync.

RCA VICTOR Models 17T200, 201, -202, -211, -220, 21T208, -217, -218, -227, -228, -229

Weak-signal area operation
(see Fig. 13).

In weak-signal areas, noisy sound may be experienced when receiving signals of 20 microvolts or less. Assuming that the receiver is

in proper alignment, the following suggestions may result in discernible improvement.

1. Watch the picture and from the top of the chassis, turn *T105* (2nd picture i-f transformer) one-half to one turn clockwise to improve sound. Adjustment of *T105* should not weaken or decrease picture contrast.

2. On high channels, a slight improvement in both picture and sound may be obtained by retouching the r-f tuner antenna trimmer *C22*, located between the 6CB6 r-f tube and the antenna matching transformer unit.

3. In some cases, retouching the tuning of *T101* sound i-f transformer may improve sound.

These adjustments are located in the chassis drawing shown here.

RCA VICTOR Models 17T200, 201, -202, -211, -220, 21T208, -217, -218, -227, -228, -229

Agc control adjustment.

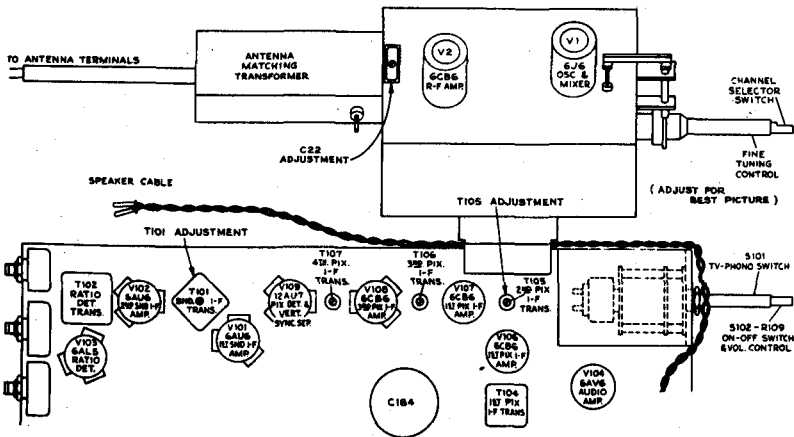

Fig. 13 — RCA Victor

In setting the age control on these receivers, care must be taken that the receiver is generating the maximum age voltage which will be required for that particular location of the receiver. If the age control is adjusted on a weak signal, the receiver may overload, bend on sync, etc., when a stronger signal is received.

The correct age adjustment, explained in equipment service notes, is important in obtaining the best performance from the receiver. Adequate picture contrast may also be difficult to obtain if the age control is not properly adjusted, inasmuch as the age control setting determines the i-f signal voltage level appearing at the picture second detector. In medium- and strong-signal areas, this adjustment should be made on the strongest signal to avoid receiver overload. In weak-signal areas, the maximum clockwise adjustment which gives best signal-to-noise ratio (minimum snow) may be preferred.

One source of difficulty not likely to be suspected is the position of the fine-tuning control. If the age control is adjusted with the fine tuning set so that the picture carrier is low on the slope of the i-f response curve, then the receiver may overload or bend on sync when the picture carrier is moved up the slope with the fine-tuning control. The obvious cure is to set fine tuning so that the picture carrier is well up the slope (fine tuning counterclockwise on KRK8) when making final adjustment of the age control.

RCA VICTOR Models 21T159,
-165, -174, -176, -177,
-178, -179

Improved vertical sync stability under conditions of reflection.

In some cases, reflections may cause vertical sync to be unstable. The following changes to the above chassis are suggested as a possible cure for this condition at a slight detrement of sync-noise immunity on weak signals.

1. Change *R185* (220-k resistor connected to cathode, pin 6, of the sync separator) to 1.0 meg, ± 10 percent, $\frac{1}{2}$ watt, stock No. 503510.

2. Change *R186* (5.6-meg resistor connected to cathode, pin 6, of the sync separator) to 3.9 meg, ± 10 percent, $\frac{1}{2}$ watt, stock No. 503539.

3. Change *R189* (680-k resistor connected to plate, pin 5, of the sync separator) to 22 k, ± 10 percent, $\frac{1}{2}$ watt, stock No. 503322.

4. Change *C160* (.022- μ f capacitor connected to cathode, pin 6, of the sync separator) to .056 μ f, 400 volts, stock No. 73791.

5. Add a 100- μ f capacitor, stock No. 39628 from pin 4 of *V113* (sync separator) to ground.

RCA VICTOR Models S1000,
TA169

Hum on phono operation.

Several of the above instruments have been found to have excessive hum when using the 960285 record changer (78/33 $\frac{1}{3}$ rpm) and require the following modifications of the record changer.

Add a jumper of .016 tinned bus wire $\frac{1}{8}$ inches long from terminal of black pickup mounting screw. The silver colored terminal pin of pickup is ground on "low" side and should be connected to the black lead and jumper. The black lead terminal must

be removed from the pickup during the soldering to avoid damaging the pickup by excess heat.

The above change was already made at the factory in later production.

RCA VICTOR Models T100,
-120, TC124, -125, -127,
TA128, -129

Replacement of deflection yoke.

Later production of 10- and 12-inch television receivers employed two different types of deflection yokes. One yoke is the older type which had an iron wire wrap core. The newer type yoke has a powdered iron core. The two yokes are easily identified in that the older iron wire wrap yoke has a cardboard outer housing, while the newer powdered iron yoke has a moulded bakelite housing.

The two yokes are not directly interchangeable for while the iron wire wrap yoke will work in the circuit designed for the powdered iron core yoke, the powdered iron yoke should not be employed in the circuit designed for the iron wire yoke unless suitable circuit modifications are made.

In receivers employing the Electronic Magnifier deflection circuit, *R181* (grid resistor of horizontal-output tube) was 470 k for the iron wire wrap yokes. This value was changed to 220 k as a compromise value for both types of yokes.

Early T100 and T120 receivers with straight deflection systems employed a 1-meg resistor for *R181* when the iron wire wrap yoke was used. Later some were built using a 150-k resistor which gave more

width and high voltage with the wire wrap yoke. When the powdered iron yoke is employed, *R181* should not be less than 470 k (which gives greatest width) nor higher than 1 meg (which gives the best linearity). A 470-k resistor was used in later production as a compromise which was suitable for either type yoke.

RCA VICTOR Models T100,
-120, TC124, -125, -127,
TA128, -129

Raster ringing with yoke replacement.

In the iron wire wrap yoke, type 201D3, the 56- μ f capacitor across a portion of the horizontal-deflection coil is connected across yoke terminals 1 and 2. Before installing the yoke, check the schematic of the receiver in which the yoke is to be installed. Some models require that the capacitor be between terminals 1 and 2, and other models specify between terminals 2 and 3. In the latter case, the capacitor must be reconnected. Failure to connect the capacitor properly will result in bad raster ringing. Except for the connection of the capacitor, the type 201D3 is an exact duplicate of the iron wire wrap yokes used in production.

If excessive raster ringing occurs on the left side of the picture of 10-inch and 12-inch receivers and the yoke capacitor is correctly connected, then remove the red yoke lead from terminal 4 of *T110* (horizontal-output transformer) and reconnect it to terminal 5. This reduces the ring at the possible slight expense of linearity. This modification is applicable to regular and electronic magnifier deflection systems.

If raster ringing occurs near the center or right side of the raster, it may be caused by misadjustment of the linearity control coil. Proper coil adjustment is best made by turning the core counterclockwise all the way and then clockwise until the ring just moves off the right side of the picture. Normally the core stud is just about flush with the outside of the chassis. This adjustment is applicable to both the regular deflection system and to the electronic magnifier systems.

On receivers with electronic magnifier deflection system, if the raster rings on the left side with the picture in the normal size, it may help to change the R-C network (*CI78*, *RI88*) in parallel with the series width coil from 10 k and 330 μmf to 5 k and 470 μmf .

RCA VICTOR Models T120,
TC124, -125, -127

Picture corner shadows
(see Fig. 14).

If it is impossible to remove picture-tube shadows by the prescribed method (see service notes) of adjusting the focus coil and ion-trap magnet, then make the following test:

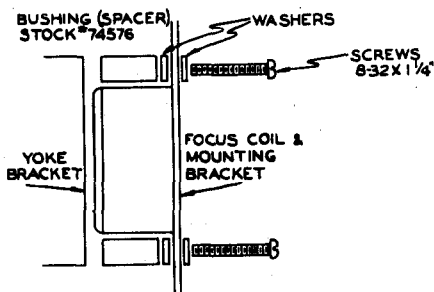

Fig. 14 — RCA Victor

1. Remove the two focus coil mounting screws (8-32 x $\frac{3}{8}$ ") and reverse the focus coil. Temporarily replace it in a position adjacent to the deflection yoke.

2. Install the ion-trap magnet and picture-tube socket in a normal manner.

3. With the receiver turned on, adjust the ion-trap magnet for the brightest raster on the screen.

4. Position the focus coil physically, and determine if the focus coil in the reversed position corrects the shadow condition. A slight readjustment of the ion-trap magnet may be necessary.

If the above test indicates that the focus coil in a reversed position is the desired position, then the mounting modification shown in the figure is recommended. The materials required for the focus coil mounting modification are given in the figure.

RCA VICTOR Model T120
Vertical nonlinearity
(see Fig. 15).

The above model receivers employing the powdered iron core yokes may be modified to prevent poor vertical linearity. This showed up as cramping at the bottom of the picture. The nonlinearity was corrected by raising the vertical-oscillator plate voltage by changes in the B-boost filter as shown in the figure. This change also prevents the formation of an extremely bright spot on the screen immediately after the set is turned off. If *CI46B* develops excessive leakage, it will cause the picture to be cramped at the bottom.

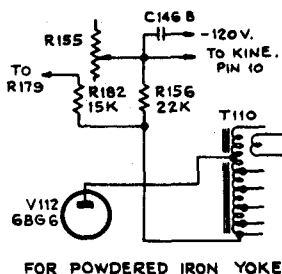
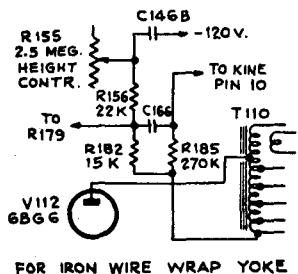

Fig. 15 — RCA Victor

RCA VICTOR Models T164, TC165, -166, -167, -168
Oscillation in a-f and v-f amplifiers.

To correct a condition of grid blocking due to high-frequency oscillations in the audio circuit of some chassis, the following changes were made early during the production of these receivers.

1. C202, C181 (.0047- μ f and 470- μ f capacitors in the plate circuit of the 1st audio amplifier), and the blue wire are to be removed from pin 6 of V120 (audio-output tube) socket and relocated on the vacant lug on the terminal board on the chassis side apron.
2. The other end of C181 is to be removed from pin 2 of V120 socket and connected to the center lug on the above mentioned terminal board.
3. C186 (.0022- μ f plate capacitor of the audio-output tube) is changed

from its former connection at C170-B (10- μ f filter capacitor connected to pin 1 of the loudspeaker plug) to tie instead at pin 4 of V120 socket.

To reduce regenerative tendencies of the video amplifier at minimum setting of the contrast control:

1. R220 (shunting 4.5-mc trap) is changed in value from 12,000 ohms to 10,000 ohms.

RCA VICTOR Models T164, TC165, -166, -167, -168
Kinky raster.

Some of the KCS40, KCS40A chassis used in the above models produce nonlinear raster edges, caused by capacitance coupling of 60- and 120-cycle harmonic components that appear on these edges due to the order of the windings in the power transformer.

Nonlinear edges on the raster can be corrected by adding a .002- μ f, 1,600-volt, oil-filled capacitor (stock No. 73817) connected from terminal 6 (red and green lead) of V115 (low-voltage rectifier) socket to chassis ground. This capacitor was added later in production to compensate for this condition.

All chassis having this capacitor added are marked by red paint on the top of the power transformer. All power transformers marked with a yellow spot on the top will not require this modification.

RCA VICTOR Models T164, TC165, -166, -167, -168
Extension cables (see Fig. 16).

The yoke, focus coil, and picture tube are fastened to the cabinet in the above series receivers and not to the chassis as in all previous models.

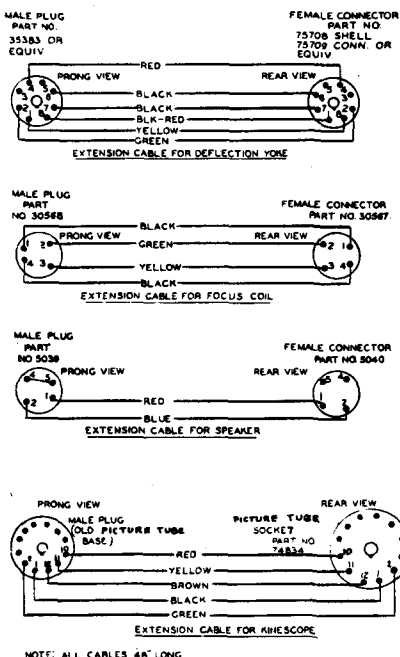

Fig. 16 - RCA Victor

When the chassis is removed from the cabinet for service, it will be necessary to unplug the yoke and focus coil. With either of these two components out of the circuit, the receiver cannot be operated because of the +B disconnect incorporated in each plug.

In order to operate the receiver removed from the chassis, it will be necessary to use extension cables to connect the yoke and focus coil.

If it is necessary to have the audio system of the receiver connected and operating during servicing, it will also be necessary to use an extension cable to connect the speaker. In the above models the output transformer is mounted on the speaker frame, and if the speaker is disconnected, the lead supplying +B to

the audio-output tubes is broken, making the audio amplifier inactive.

The figure describes how these extension cables can be made, also stock numbers of plugs and connectors used.

RCA VICTOR Models T164, TC165, -166, -167, -168
Insufficient or no width
 (see Fig. 17).

In some of these receivers, deflection failures have occurred with the following symptoms:

1. Insufficient width, keystone raster, arcing, etc. Generally, this condition is caused by the dress of the leads to terminals 1 and 3 of the horizontal yoke. Shorting of these leads to turns of the horizontal yoke winding will account for a small horizontal raster, and the voltage difference between the turns will account for the arcing.

2. No horizontal deflection. In some cases the leads of the horizontal section will make contact with the vertical section of the yoke. Under this condition there will be no horizontal deflection. There is also a possibility that the saran, or insulating material, between sections will break down, resulting in arcing and no horizontal deflection.

Since the majority of yoke defects are improper lead dress, the repair can often be effected in the field. The following is a logical approach:

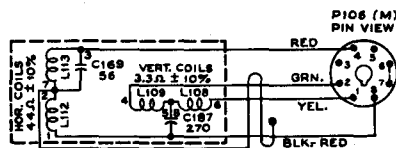

Fig. 17 - RCA Victor

Remove the yoke plug from the chassis and make a resistance check to possibly determine the defective section or sections:

Normal Readings at Plug P106

Pin 4 to Pin 8 —
Measures approximately 40 ohms

Pin 1 to Pin 2 —
Measures approximately 3 ohms

Pin 1 to Pin 8 —
Measures approximately infinity

Pin 4 to Pin 2 —
Measures approximately infinity

If low resistance readings can be changed by squeezing the bakelite cap of the yoke, this is an indication that lead dress is at fault.

To clear a short, use a long probe and change the lead dress until the resistance readings are normal. Check the lead dress on yoke terminals 1 and 3 first.

If the resistance check is normal and the yoke is still defective, then connect the yoke plug, but do not insert the picture tube. Turn the receiver on and visually note the location of the arc. Once the location of the improper lead dress is determined, clear as before until the arcing condition does not exist. This type of trouble is of course not indicated by a resistance test, but is apparent only by the arcing condition due to the proximity of the wires.

The majority of failures are due to lead dress as pointed out above, however, one should not overlook the possibility of defective yoke capacitors and improperly soldered connections.

RCA VICTOR Models with
KRK2, -5, -7, -8 tuners
Installation of high-pass filter
(see Fig. 18).

If interference is experienced due to the presence of strong signals below 50 mc, it can usually be eliminated by the use of a high-pass filter. To be effective, the filter must be installed at the r-f tuner units with leads as short as possible and the case of the filter connected to the r-f unit chassis.

Part (A) of the figure shows the method of attaching the antenna input connectors to the filter so that

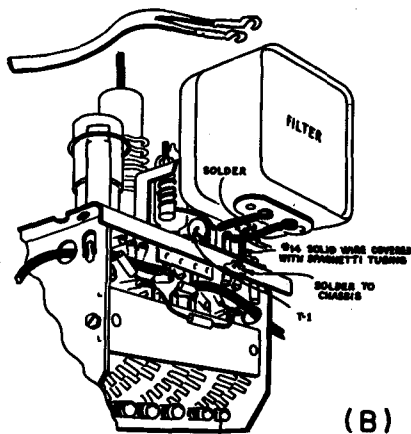
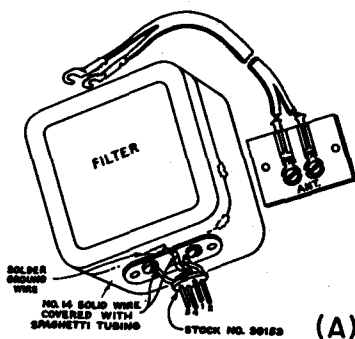

Fig. 18 — RCA Victor

it can be plugged directly into the antenna matching units employed with KRK5, KRK7, and KRK8 r-f tuners.

Part (B) of the figure shows the method of mounting the filter on receivers employing KRK2 r-f units.

RCA VICTOR Models with
KRK2, -5, -7, -8 tuners
Tuner oscillator tracking
(see Fig. 19).



Fig. 19 — RCA Victor

The frequency of the r-f tuner oscillator is a function of the circuit inductance and capacitance, and since the steps of inductance are fairly well fixed on channels 7 to 12, inclusive, the only sizeable variables that are available are the capacitance and the channel-13 inductance.

On KRK2 "C" consists of stray capacitance, fine-tuning capacitance, and (in some units only) a "gimmick," a piece of insulated wire about 1/4 inch long between the plate pins on the tube socket. On KRK5, KRK7, and KRK8, "C" is composed of stray capacitance and a real adjustable capacitor.

On KRK2, "C" becomes less with a counterclockwise rotation of the fine-tuning control. On KRK5, KRK7, and KRK8, a clockwise rotation of the fine-tuning control gives less capacitance.

To properly track an r-f unit oscillator on the high channels, the following process may prove helpful:

1. Make sure that the adjustment screws for channels 7 to 12, inclusive, are spaced about 1/32 of an inch (1 1/2 turns from full-in position) away from the rivets holding the inductance strap.

2. Tune for correct channel 13 oscillator frequency by using the readily available adjustments for the purpose (a capacitance trimmer on the KRK8 and an inductance slug on the KRK5).

3. Without moving the fine-tuning control, turn the detent to channel-7 position and note the oscillator frequency.

4. If the noted frequency is higher than it should be, the channel-13 capacitance should be increased and the channel-13 inductance should be decreased. Go back to channel 13 and make the necessary changes to give both the correct frequency and an approximation of tracking correction. See the chart.

5. If, on the other hand, the channel 7 oscillator frequency is lower than it should be, the channel-13 capacitance should be decreased and the inductance increased. See the chart.

On the KRK5, KRK7 and KRK8, the channel-13 capacitance adjustment is fairly obvious. Screwing the stud out gives less capacitance, in, gives more capacity.

After the proper adjustments have been made to give oscillator tracking within 1.0 mc or so from 13 to 7, each channel can be individually aligned by using the available screw trimmers.

For field use in areas having two or more high-channel stations, a slightly different approach may be taken:

KRK2

To Increase Channel-13 Capacitance

1. Pick oscillator tube to give lower frequency.
2. Add a "gimmick" between oscillator tube socket plate pins or move the existing "gimmick" closer. (Use a production sample for reference; some units already have a "gimmick".)
3. Check cross-feed capacitors for correctness of value.

To Decrease Channel-13 Capacitance

1. Pick oscillator tube to give higher frequency.
2. Move "gimmick" away from plate pins.
3. Check cross-feed capacitors for value.

To Increase Channel-13 Inductance

1. Move channel-13 slug in if the studs protrude $\frac{3}{8}$ of an inch, or less. Move out if they protrude more than $\frac{3}{8}$ of an inch.

(The channel-13 slugs are brass and normally inserted through the coil. If the slug screws stick out about $\frac{3}{8}$ of an inch, they are in their minimum inductance position and any tuning, either in or out, gives a change toward the maximum inductance position.)

To Decrease Channel-13 Inductance

1. Move channel-13 slug out if the studs protrude $\frac{3}{8}$ of an inch, or less. Move in if they protrude more than $\frac{3}{8}$ of an inch.

KRK5 and KRK7

To Increase Channel-13 Inductance

1. Screw brass slug out of L1 and L2.

(These slugs are available from the bottom of the r-f unit chassis and are normally cemented lightly.)

To Decrease Channel-13 Inductance

1. Screw brass slug into L1 and L2.

KRK8

To Increase Channel-13 Inductance

1. Screw brass slug out of coil.

(This slug is available from front of unit only.)

To Decrease Channel-13 Inductance

1. Screw brass slug into coil.

1. If the highest high channel is aligned with the fine tuning centered and the lowest high channel calls for a clockwise rotation of the fine-tuning control, step 4, above, applies for KRK2 and step 5 for all other units.

2. If the highest high channel is aligned with the fine tuning centered

and the lowest high channel calls for a counterclockwise rotation of the fine-tuning control, step 5 applies for KRK2 and step 4 for other units. (Step 4 means an increase of channel-13 capacitance and a decrease of inductance. Step 5 means a decrease of channel-13 capacitance and an increase of inductance.)

RCA VICTOR Models with KRK2
tuners
**Coax to balanced line
matching network**
(see Fig. 20).

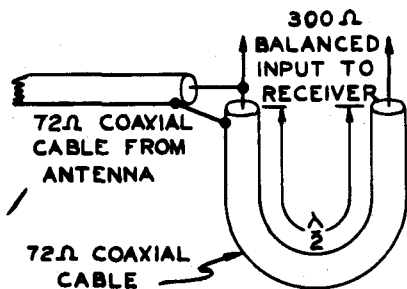

Fig. 20 — RCA Victor

In some locations it may be necessary to use 72-ohm coax transmission line between antenna and receiver because of reflection or interference pick-up. Later receivers are provided with a 72-ohm coax input in addition to the usual 300-ohm input. Early receivers employing the above series r-f tuner units are provided only with 300-ohm balanced input. To connect the coax to these early receivers, construct a network as shown in the figure. The matching section should be one electrical half wavelength long for the picture carrier of the weakest signal received.

Note: In calculating this half wavelength, be sure to take into account the reduced velocity of energy propagation along coaxial line (usually about 66 percent).

RCA VICTOR Models with KRK5,
-7, -8 tuners
Correcting video i-f response
(see Fig. 21).

Curve (A) illustrates a normal video i-f response. Curves (B) and (C) illustrate results that are obtained in some cases due to abnormal conditions in the i-f system.

“Correcting” curve (B) by using the adjusting slugs usually results in placing the picture carrier minus .75 mc point at the top of the curve which, again, is not the proper alignment. “Correcting” curve (C) usually results in very much reduced gain and an excessive amount of adjacent-channel response.

To correct curve (B) with the minimum amount of bad effects, the turns of the second i-f trap (*T102*) should be moved away from the primary of the same transformer. Moving the whole trap coil about two or three nicks up the coil form is usually sufficient.

To correct curve (C), the following must be checked:

1. Make sure that the cathode sound trap is not shorting.
2. Check the sound i-f alignment.
3. Check sweep and scope response by removing “blanking” on the sweep and checking for response overlap. (A defective scope cable or input can cause overshoot on this side of the responsive curve.)
4. If none of the above results in satisfactory curve, then the sound take-off trap coil (*T103*) should be moved up and away from *T103* primary. One notch on the coil form is usually sufficient.

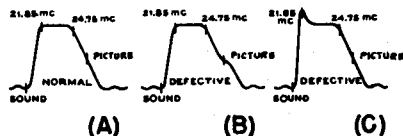

Fig. 21 — RCA Victor

RCA VICTOR Models with KRK5,
-7 tuners

**Reduction of broadcast
interference (see Fig. 22).**

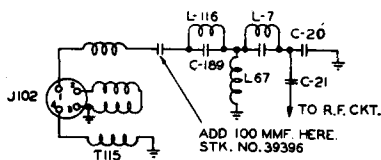

Fig. 22 — RCA Victor

In some cases where a television receiver is in operation on a weak signal but near a strong a-m broadcast station, interference has been experienced. To cure, insert a 100- μmf capacitor between the high side of *T115* and *L116*, as shown in the figure.

In severe cases of broadcast interference, it is recommended that a coil such as *L80* (series resonant trap for 21.8 mc in converter grid circuit) in KRK2 r-f units be inserted from terminal 1 of *J102* to ground.

RCA VICTOR Models with KRK5,
-7 tuners

I-f harmonic interference.

This interference has appeared in a number of television receivers. The following discussion applies specifically to models *T100*, *T120*, and *T164* and in general to other models using KRK5 series or KRK7 r-f units which may have differing component identification.

Sound I-F Interference:

In some instances harmonics created in the sound i-f find their way back into the receiver-input circuits

and create interference. The sound i-f third harmonic falls into channel 3, the fourth harmonic falls into channel 6, the ninth harmonic falls into channel 9, and the tenth harmonic falls into channel 13. These may be identified by removing the second sound i-f tube to see if the interference disappears. If it does, then the harmonics are created in the sound i-f stage or in the discriminator. The following information may be helpful in eliminating or reducing such interference.

1. The ground wire running from pin 2 of the second sound i-f socket, which runs approximately an inch and a half to a lance toward the rear of the chassis, should be dressed away from pin 1 of this socket, and as far as possible toward terminal B of *T112* (sound i-f transformer). This will cause the wire to run a curve rather than a straight line and may require a slight lengthening of the ground lead.

2. Carefully check the sound i-f and discriminator transformer shield cans and wiring. The shield cans should be tight in place and well grounded to the chassis. In order to insure a good ground of these shield cans, it may be desirable to place some solder on the chassis where the can contacts the chassis so that the can may be pulled into the solder when clamped in place.

3. Carefully check the lead dress in the discriminator stage, particularly the leads connected to the discriminator transformer, making sure that they conform to all lead dress information contained in the service notes for the instrument involved.

4. Make sure that all bypass capacitor leads in the sound i-f system

are as short as possible and that the capacitor itself is dressed close to the chassis.

5. Make certain that the antenna lead-in from the terminal board on the rear of the cabinet to the r-f tuner input is dressed away from the chassis so as not to cause any unbalanced condition to the receiver input.

6. The normal discriminator wiring is from pin 1 of the 6AL5 to the tube socket shield, then to pin 6 and from pin 6 to ground. Disconnect the wire from ground to pin 6 and ground pin 1 separately with as short a lead as possible.

Note: In some instruments in later production, a zinc discriminator shield can is being used. This can is soldered directly to the chassis.

Picture I-F Interference:

In some instances harmonics created in the picture i-f find their way back into the receiver-input circuits and create interference in the picture. The interference takes the form of a beat pattern which varies with fine-tuning adjustment. In general, the more sensitive the receiver, the more susceptible it is to this sort of interference.

With the 21.25-mc sound i-f and 25.75-mc picture i-f system currently in use, the third picture i-f harmonic falls into channel 5 and the eighth picture i-f harmonic falls into channel 12. If such interference is experienced, it may be reduced by the following steps:

1. Check the antenna transformer *T115*, also *L67* (antenna filter shunt coil). Check the antenna transmission line for continuity. If any of the above are defective, the interference may be severe.

2. Shield the fourth picture i-f and video-amplifier tubes.

3. Dress the antenna lead from the r-f unit to the cabinet terminal board as far from the chassis as possible.

4. The wire leading from *L102* (detector shunt peaking coil) and *T106* (5th picture i-f transformer) to *R120* (10-ohm resistor connected to peaking coil) must lie tight on the chassis.

5. The 10- μmf detector bypass capacitor should be wired between terminal C of *T106* and pin 7 of the *V105* (detector) socket with the shortest possible lead lengths and should be dressed down close to the chassis and away from other wiring.

6. The peaking coil, *L103* (detector series peaking coil) should lie not over $\frac{1}{4}$ inch off the chassis with the shortest possible leads and should be dressed away from other wiring.

7. The 1,500- μmf bypass capacitor *C193* which goes from plus B to ground at the end of *R118* (1,000-ohm plate decoupling resistor in 4th picture i-f amplifier) must be in good condition.

8. The filters on the r-f unit bias and plus-B supplies must be in good condition.

A few receivers have been found to suffer harmonic interference due to a peculiar fault in the 1,500- μmf bypass capacitors. These capacitors check normal at all frequencies up to 150 mc but exhibit a higher resistance above this point. Therefore, these capacitors will work satisfactorily in i-f positions but show up defective when used to bypass high frequencies such as are found in the r-f unit or harmonics of the sound and picture i-f's. Therefore, in such

cases it would be wise to check these capacitors.

A weak 12AU7 (*V106*) may aggravate the harmonic interference by causing a reduction of agc voltage.

In general, it is easier from a design standpoint to eliminate low order sound harmonics from the sound circuit than harmonics of higher order from the r-f channels, such as the tenth, etc., since bypass capacitors and ground returns are more effective at the lower frequencies. Likewise, it is more difficult to bypass picture i-f harmonics than sound i-f harmonics, since the impedance of the picture circuits is relatively low compared to that of the sound circuits.

Receivers using built-in antennas, or having the transmission line draped around the cabinet, are more susceptible to this type of interference. During the installation of a television receiver, this type of interference can be reduced by obtaining as strong a signal from the antenna as possible, and adjusting the agc control to supply a lower peak voltage to the detector. Thus a higher ratio between tv signal and the i-f harmonic is obtained.

As a last resort, the receiver may be aligned to different i-f frequencies. This has the effect of pushing the interference into other channels.

RCA VICTOR Models with KRK8 tuner

Difficult alignment of channels 5 or 6.

It is suggested that the f-m trap adjustment (*L203*) be adjusted to minimum inductance (slug out) so that the effects of this trap, which is capable of being tuned to channels

5 or 6, will not adversely affect the response of these channels during alignment.

RCA VICTOR All models with KRK11 tuner

Low oscillator-injection voltage.

If low oscillator-injection voltage is encountered in the above r-f unit, it may be necessary to select a 6X8 tube which will give proper injection when the r-f unit is properly aligned. Recent changes in the circuit and parts make it easier to obtain sufficient injection with average 6X8 tubes. R-f units in which these changes are made are marked M1.

RCA VICTOR All models with KRK11 tuner

Short circuit due to improper lead dress.

In several early production units, difficulty has been reported due to the shield of the cable from *T1* (converter transformer) shorting against *C28* (1,500- $\mu\mu\text{f}$ capacitor in 110-volt bus to 1st r-f amplifier). When working on one of these units, take care not to disturb the dress of this cable so as to make this short more likely to happen in service. It may also be a worthwhile precaution to wrap the shield of the cable with several turns of tape at the point where it passes *C28*. In late production units, this lead has been dressed so that a short cannot occur.

RCA VICTOR Models with 10BP4, 12LP4, 16AP4 picture tubes

Use of ion trap with replacement tubes.

Later RCA tubes of the above types have a new type of electron

gun similar to the one employed in the type 16GP4 picture tubes. In most cases it will be found that the electromagnetic ion trap magnet or the two-ring permanent-magnet type ion trap originally employed with these tubes will also operate satisfactorily with the tubes employing the newer guns. However, if trouble should be experienced, it can be eliminated by the use of the single permanent-magnet ion trap employed with 16GP4 picture tubes.

RCA VICTOR All models with 16-, 17-, 19-, and 21-inch picture tubes
Improved picture tube dust seal (see Fig. 23).

Later production receivers use an improved type of picture-tube dust seal. This seal is made of special (anti-corona) sponge rubber and is arranged to fit the space between the mask and tube cone. It is available from distributors as Stock No. 76631 for use on instruments having either 17-inch or 21-inch tubes. This same dust seal is also recommended for use with other television receivers previously manufactured using 19-inch, 17-inch, or shortneck 16-inch picture tubes.

It should be necessary to remove the picture tube, the dust seal should be removed first. When replacing the dust seal, care should be used in its installation so that its advantages will be retained. The illustration shows the assembly of the picture tube, mask, and dust seal in model 17T155. The assembly in other models is very similar.

To install the dust seal, proceed as follows:

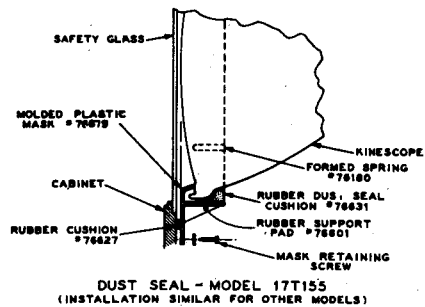

Fig. 23 — RCA Victor

1. Apply cement (see note below) around entire periphery of both the picture tube and the mask surfaces which are in contact with the dust seal. Caution: Do not apply cement to the high-voltage clip. The spring-mounting clips should be pushed securely in place so that they do not protrude beyond the mask flange.

2. Install dust seal, starting at bottom center of mask, with tapered side against the picture tube, pushing it securely into the space between the flange of the mask and the cone of the tube. Caution: Avoid stretching the seal during installation. The seal, when pushed in properly, should be bottomed against the flange of the picture tube.

3. After the seal has been installed completely around the tube, overlap the two ends 1 inch and cut off square. Apply cement to the two ends, push back the lap and butt the two ends together. Push seal in to make a secure fit all around the picture tube.

Note: The rubber cement commonly used for sticking papers together is recommended for cementing the dust seal. It may be obtained, in small bottles having a brush applicator, at most stationery stores.

RCA VICTOR Models with 17CP4, 17QP4, 21AP4 picture tubes

Demagnetizing electron gun.

If certain picture tube electron gun parts become magnetized, poor focus may result. To demagnetize these tubes, connect a 630TS receiver electromagnetic focus coil to 110 volts a.c. and pass the coil slowly over the picture-tube neck, past the gun and slowly withdraw.

RCA VICTOR Model with 17CP4 picture tube

Substitution of electrostatic focus picture tube (see Fig. 24).

Early production 17-inch television receivers employed a magnetic focus picture-tube type 17CP4. Late production receivers employed the electrostatic focus tube type 17GP4. This tube dispenses with the focus magnet. The electron gun employed in the tube is of an improved design to provide good uniformity of focus over the entire picture area. Furthermore, focus is maintained automatically with variation in line voltage and with adjustment of picture brightness. To identify receivers, those employing the electrostatic focus tube have a letter "B" following the model number. The chassis

in the "B" series of receivers is different from early production units only to the extent of the change necessary to operate the new picture tube.

As shown in heavy lines in the partial schematic, a new high-voltage transformer is required and a 1V2 rectifier is provided to supply the focus potential to the picture tube. A focus-control potentiometer is also supplied and is conveniently located on the back of the chassis.

Since the focus magnet is dispensed with on the 17GP4, a new centering magnet is provided to center the picture on the screen. This magnet assembly is in the form of two wire rings mounted on a non-magnetic form which is placed around the neck of the picture tube, and at a distance of about three-eighths of an inch in back of the deflection yoke. When the magnets are rotated on the tube so that the gaps in the rings are together, then maximum picture shifting effect is produced. When the rings are rotated so that their gaps are 180 degrees apart, then little or no shifting of the picture is obtained. To shift the picture, rotate one of the magnets with respect to the other. To move the picture in a desired direction, rotate the entire centering mag-

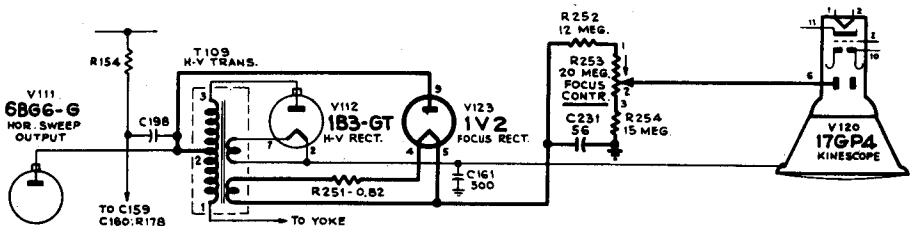

Fig. 24 — RCA Victor

net assembly around the neck of the picture tube. Repeat these two adjustments until the picture is properly centered and no corner shadows are obtained.

The ion-trap magnet on the neck of the picture tube should be adjusted for maximum brightness, the same as on previous receivers. The position of the ion-trap magnet also has an effect on picture centering. However, it should not be used to improve centering if such adjustment causes any reduction in picture brightness. Any adjustment of the ion-trap magnet which causes a reduction in brightness, causes the electron beam to strike the edge of an aperture in the gun structure and may eventually cause damage to the picture tube.

RCA VICTOR Models with 17GP4 picture tubes

Inability to focus properly.

Setting up and focusing electrostatic picture tubes (such as the 17GP4) require slightly different techniques than were used on magnetically focused tubes. Adjustment of the brightness control, centering magnet, ion-trap magnet, and the focus potentiometer, all have some effect on spot size and shape, and consequently influence focus voltage. The ideal condition is reached when the tube is focused (a) with the lowest possible focus-anode voltage, (b) when best test pattern vertical-wedge resolution occurs simultaneously with the best raster-line focus, (c) when good focus is obtained at high and low brightness levels, and (d) when focus is obtained well within the range of the focus control.

The proper focus procedure is as follows:

1. Set the brightness control for average brightness.

2. Set the focus pot slightly counterclockwise from the best focus position.

3. Adjust the ion-trap magnet for maximum brightness. Within the range of maximum brightness, a region of best focus will occur. Set the ion-trap magnet within this region of best focus. Do not use the ion-trap magnet as a centering adjustment.

4. Center the picture by adjustment of the centering magnet as described in the service notes.

5. Repeat the above procedure until no further improvement is obtained.

Check for vertical and horizontal resolution as follows:

With the brightness control set for average brightness, adjust the focus pot for maximum resolution in the vertical wedges of a test pattern. The raster lines should be clearly visible at this point. If the raster lines are not in focus, turn the focus pot until they are in best focus. This should occur within a very few degrees of rotation of the focus pot and without appreciable loss of definition in the vertical wedge. In some instances, a slight compromise may be necessary for final focus adjustment. With the brightness control set for average brightness, focus on the test pattern and favor the vertical-wedge resolution as long as the raster line structure is visible.

Then check for focus with change of brightness as follows:

1. Turn the brightness control for low picture brightness. Best focus

should occur in the center of the picture.

2. Turn the brightness control for maximum usable brightness. Best focus should now occur near the edge of the tube with the center only slightly out of focus. This condition gives the best average focus.

Notes:

1. If vertical and horizontal resolution do not occur simultaneously, it may be due to the centering magnet. Try the following change: If for example, the tab nearest the yoke is 45 degrees clockwise from the rear tab, move the tab nearest the yoke to 45 degrees counterclockwise from the rear tab, then rotate the entire centering-magnet assembly approximately 180 degrees around the neck of the tube until the picture is again centered. Repeat the procedures outlined above.

2. One type of centering magnet currently employed consists of two magnetic rings with four tabs, two attached to each ring. A second type consists of two small bar magnets attached to two discs of metal with an off-center hole for the neck of the picture tube. This second type magnet should be assembled with the cardboard sleeve toward the yoke, the tabs upward, and the tab closer to the yoke counterclockwise from the rear tab. This position appears to give the most nearly circular spot and best focus in the majority of cases. If the tabs on this second type centering magnet are approximately 90 degrees apart to obtain proper centering, and if good focus cannot be obtained by the procedures outlined in the above paragraphs, then it may be advisable to replace the centering magnet.

3. If the picture focuses at the extreme counterclockwise end of the focus control, it may be due to leakage in the picture tube. If the picture focuses at the extreme clockwise end of the focus control, it may be due to leakage external to the picture tube or to a defective 1V2 tube. If difficulty is experienced in centering the picture on the screen, it may be desirable to rotate the picture tube 180 degrees.

RCA VICTOR Models with 19AP4A picture tubes

Focus magnets for picture tubes.

The standard type of 19AP4A picture tube uses the focus magnet, stock No. 75504. However, a number of type 19AP4A tubes were being used which were coded with a small dot of green paint on the neck of the tube near the type number designation. Tubes so coded require a stronger focus magnet available under stock No. 75935.

RCA VICTOR Models with metal picture tubes

High-voltage arcs at picture tube.

During days of humid weather, difficulty may be experienced with arcing across the bell of metal cone picture tubes due to a collection of dust and moisture around this area.

In the past, many remedies have been suggested, all of which have been helpful for a short period of time. The best field remedy found to date has been an application of *Car-Plate*, made by S.C. Johnson & Son, Racine, Wis.

The following procedure should be employed:

1. Remove the entire coating on glass bell, using methanol or acetone.
2. Wash the glass bell thoroughly with a good detergent.
3. Dry the glass bell thoroughly.
4. Apply a good coating of Johnson's *Car-Plate*. Allow to dry, then wipe off the white residue. Brush application is satisfactory.

RCA VICTOR All models with
EM-PM focus
coils

EM-PM focus coil troubles.

In some cases, trouble has been experienced with EM-PM focus coil. These difficulties show up as inability to reach focus with the focus control.

If everything is operating properly, the overall focus and focus regulation is much better with the newer coil than with the straight EM type.

The troubles with the PM-EM coil can be summarized as being one or more of the following:

1. Incorrect placement of the coil on the picture-tube neck.
2. Too much PM.
3. Too little PM.
4. Polarity of the EM winding reversed in color code and/or hook-up.

The normal placement of the coil is with the front plane of the coil approximately one-quarter of an inch behind the back cover of the yoke. Moving the coil back on the picture tube will, in effect, be the same as reducing the total flux of the coil. Some cases of too much PM can be thus corrected. In a few such cases, the correct focus was obtained at the sacrifice of loading spring tension. It is suggested that washers be used to bush up the springs if they are too loose when the correct focus is

obtained. Under no circumstances should the EM portion of the coil be reversed to compensate for too much PM. Doing this will eventually run the PM down to zero and make the coil useless along with producing a service call every week or so.

(It may appear that an aiding flux might gradually increase the PM flux. Such is not the case because the PM material is magnetized to a greater density than the EM portion).

Polarity may be checked by the following method:

1. Get as good a focus as possible with the coil up against the yoke. Note the voltage across the EM winding.

2. Move the coil as far to the rear as possible and turn the focus control so that condition 2 approximates condition 1 in appearance. Note the voltage across the EM winding.

The voltage across the EM winding should be higher in condition 2 than in condition 1.

(The effects of magnetism are minimized as the coil is moved to the rear so that more magnetism must be supplied.)

If condition 2 reading is lower, or if no satisfactory comparison can be obtained by adjustment, then the EM winding is reversed and should be reconnected in the proper way.

A tag should be attached to the set to indicate a change if the color code is incorrect so that some future serviceman knows what has been done.

If position and polarity have been checked and it is discovered that there is too little PM, the entire coil must be replaced. The 6BG6 supply

should not be reconnected to add to the focus current because it overloads the coil and the shunt potentiometer.

On some sets it will be found that by shorting the 10-ohm resistor (connected to arm of focus control) enough control is obtained. This should not be done since the focus potentiometer would be overloaded if the arm is set near the short-circuit end. Moving the coil toward the rear will solve a problem of this type and still permit good focus with the 10-ohm resistor in the circuit.

RCA VICTOR All models
Improved contrast in weak-signal areas.

Ion-trap adjustment, especially in weak-signal areas, should not be overlooked as a means of obtaining increased contrast. The proper setting of the ion-trap magnet depends somewhat upon the brightness-control position used for best picture. A minor readjustment for maximum brightness may result in an improved picture in weak-signal areas when receivers have previously been adjusted for operation on stronger signals.

RCA VICTOR All models
Barkhausen oscillations.

The usual effects of Barkhausen oscillation make themselves evident by producing one or more dark, sharply defined vertical lines on the left side of the picture or raster. These lines vary in width and/or intensity from one channel to another and from one brightness level to another. They are usually more apparent on the higher frequency channels and at low brightness settings. In the worst cases, these oscil-

lations tend to upset horizontal synchronization. In the mild cases, they usually annoy the customer more than they do the set.

The only tube in the set that could cause this interference is the 6BG6G since it is the only one that has a positive grid-to-plate potential at any time. The critical voltages are reached just about the time the tube calls for deflection of the beam to the right-hand side of the raster. This happens when the spot is about one-third the way across horizontally.

Following are a few solutions to the problem:

1. Change the drive-control setting.
2. Replace the 6BG6G with another. (The tube being replaced will probably operate satisfactorily in some other chassis.)
3. Change antenna or antenna lead-in placement.

The first method is critical with respect to line voltage and should be adjusted to give satisfactory operation on all available channels at any line voltage encountered.

The installations using either a built-in antenna or an indoor antenna are often subject to an undue amount of pickup because of their location. The lead-in, if draped near the high-voltage compartment can also cause trouble. The solution for this type of trouble is obvious.

RCA VICTOR All models
Interference causes and cures.

The following tabulation gives various types of television interference along with suggested cures:

Type Of Interference	Character Of Interference	Cause	Suggested Remedies
F-m	<ol style="list-style-type: none"> 1. Diagonal bars or herringbone crosshatch in picture. 2. F-m sound in television sound. 	<ol style="list-style-type: none"> 1. F-m station on image of low channel television station. 2. F-m signal overloading r-f unit creating harmonic in receiver which falls on high-band television channel. 3. Second harmonic of f-m transmitter falling on a high-band television channel. 	<ol style="list-style-type: none"> 1. Adjust f-m trap in receiver (if used) to attenuate f-m signal. Also use stub at the receiver, cut for the fundamental of the f-m station. 2. Vary orientation of television antenna to reduce f-m pick-up. 3. Second-harmonic radiation must be suppressed at transmitter. Orient television antenna to reduce harmonic pickup.
42 Adjacent-channel Interference	Undesired station causing blanking out of desired station or causing wind-shield-wiper effect.	<ol style="list-style-type: none"> 1. Inadequate receiver selectivity. 2. Attempting to receive stations beyond their service area. 	<ol style="list-style-type: none"> 1. Align the receiver with special attenuation to the adjacent-channel traps. Install additional adjacent-channel traps. 2. Use antenna with good front-to-back ratio, if applicable, or orient antenna to minimize adjacent-channel pick-up.
Co-channel Interference	Horizontal bars moving up and down through picture. In some cases the sound may be garbled.	Two stations operating on same channel. Receiver located so as to receive signals from both stations.	Use antenna with good front-to-back ratio on that particular channel if stations are in opposite directions. Orient antenna for best results.
Amateur	<ol style="list-style-type: none"> 1. Crosshatch, horizontal or diagonal bars in picture. In instances of extreme interference, picture may be reversed (negative) or may be blocked out with no visible beat pattern. 2. Sound in television sound. 	<ol style="list-style-type: none"> 1. Pick up of fundamental, harmonic, or parasitic frequencies from amateur transmitter. 2. Overload of television r-f unit from fundamental of amateur transmitter. 	<ol style="list-style-type: none"> 1. If 28-mc interference is picked up in i-f amplifier, then shield i-f's. 2. If 28-mc interference leaks through KRK2 r-f unit, readjust adjacent-channel sound trap to reject 28-mc interference. 3. Install a good high-pass filter as close to receiver input as possible (directly on head-end unit) with short ground connection. 4. With KRK8 r-f tuner, avoid use of 72-ohm coax transmission line. 5. If interference is definitely due to harmonics or parasitics, arrange with amateur for reduction of spurious signals. He can frequency multiply in low-power stages, shield transmitter, and install low-pass filter in transmitter antenna transmission line.
Interchannel	Diagonal bars in picture or undesired picture superimposed on picture.	Double conversion or oscillator harmonic conversions.	<ol style="list-style-type: none"> 1. Adjust f-m trap. 2. Install stub cut to interfering frequency. 3. Orient antenna to reduce interference.

Type of Interference	Character of Interference	Cause	Suggested Remedies
Diathermy and R-f Heating Equipment	Herringbone pattern on picture. Also appears as heavy black horizontal bars across picture.	Pick up of fundamental, harmonic, or parasitic radiations from diathermy equipment.	<ol style="list-style-type: none"> 1. Same approaches as for radio-amateur interference. 2. Have diathermy owner employ reliable diathermy technician to eliminate harmonic or spurious radiations.
Ignition	Horizontal streak across picture, noise in sound, possible loss of sync.	Mostly due to weak signal being received from television station.	<ol style="list-style-type: none"> 1. Use outside antenna to get good signal. Locate antenna away from streets or sources of interference. 2. Use coax or twinex transmission line.
Horizontal-oscillator Radiation	Causes heterodyne whistle in a-m broadcast radio receiver.	Harmonics of 15-kc horizontal oscillator or television receiver beating with broadcast-band signals.	<ol style="list-style-type: none"> 1. Try to secure stronger signal from radio station by better radio antenna. 2. Separate television and radio sets by as much distance as possible. 3. Use interference filter on power line at television chassis. Put earth ground on chassis. Shield television chassis.
Sound and Picture I-f Harmonics in Picture	Herringbone pattern on picture when caused by sound i-f harmonics, or bars when caused by picture i-f harmonics.	Harmonics of sound or picture i-f's getting back into r-f unit.	<ol style="list-style-type: none"> 1. Lead dress around sound and picture i-f's critical. Defective by-pass capacitors. 2. Use outdoor antenna. Keep lead-in away from last i-f stages. 3. Shift i-f frequencies slightly.

44



REMINGTON (Rembrandt)

Models 80, 130

Operation in high-noise areas

(see Fig. 25).

Since noise levels are quite high in some localities, afc has been added in later models to minimize disturbances. The circuit utilizes a 6AL5 double diode to develop the oscillator-control voltages and receives its signal from the plate of the 6AS7 discharge tube. The circuit used is shown in part (A) of the figure.

In conjunction with this circuit, the bias arrangement is changed on

the 6AG7 video-output tube. The cathode of this tube is rerouted to ground through a 150-ohm resistor and bypassed with a 100- μ f, 25-volt capacitor. The grid-coupling capacitor must be removed and replaced with a direct wire for operation of this circuit. This latter arrangement alone (shown in part B of the figure) will help to minimize noise and is advised for locations where noise is prevalent.



SCOTT

Models 710, 720,
910, 920, 924,
M1003

Increasing horizontal deflection.

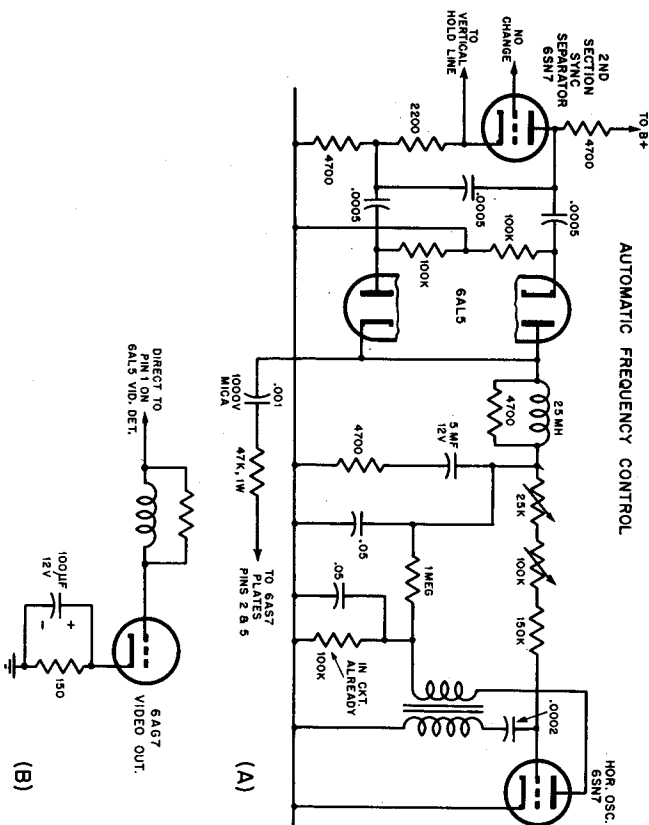

Fig. 25 — Remington

45

In extreme cases of insufficient raster width, a .05 to .1- μ f capacitor added across the width coil will produce additional horizontal deflection.



SEARS ROEBUCK

Chassis 100.107, -.111,
-.112, -.115, -.120, -.121

Installation of adjacent-channel sound trap (see Fig. 26).

Adjacent-channel sound trap, part No. 520131, comprising a slug-tuned coil and fixed ceramic capacitor, was designed to minimize interference caused by the sound carrier of the lower frequency adjacent channel.

When required, the adjacent-channel sound trap is to be added in the screen circuit of tube *V8* (6AU6), second intermediate-frequency amplifier. This can be accomplished by following the procedure outlined below:

1. Mount the trap coil in the hole located directly in front of tube *V9* (6AU6), third intermediate-frequency amplifier. The coil must be inserted from the under side of the chassis and pushed through the hole until the mounting clip snaps into position.

2. Disconnect resistor *R174* (1,000 ohms) from pin 6 of tube *V8* (6AU6), second intermediate-frequency amplifier.

3. Carefully disconnect capacitor *C172* (1,000 μ f) from pin 6 of tube *V8* (6AU6) and from chassis ground.

4. Disconnect the second intermediate-frequency coil *L173* from pin 6 of tube *V8* (6AU6).

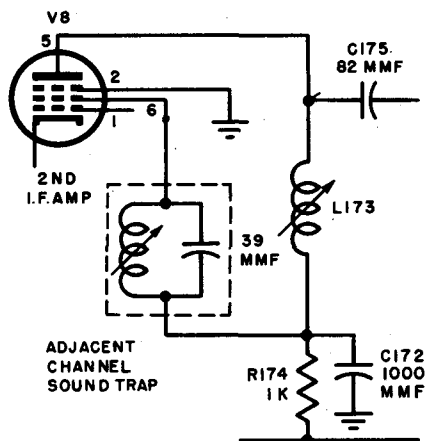

Fig. 26 — Sears Roebuck

5. Connect one terminal of the trap coil directly to pin 6 of tube *V8* (6AU6).

6. Connect other terminal of trap coil to the terminal of second intermediate-frequency coil *L173* which was disconnected in step 4.

7. Connect open end of resistor *R174* (1,000 ohms) to the junction of second intermediate-frequency coil *L173* and trap coil.

8. Connect capacitor *C172* (1,000 μ f) removed in step 3, by wiring one end to the junction of second intermediate-frequency coil *L173* and resistor *R174*. The other end of the capacitor should be grounded at a point close to the second intermediate-frequency coil.

The circuit diagram shows this sound trap wired into the receiver circuit.

After installing the adjacent-channel sound trap in the proper manner, it will be necessary to make the following adjustments:

1. Rotate the slug until the stem is out as far as possible.

2. Properly tune receiver for a normal picture by using fine-tuning control on front panel. Do not touch this control during the rest of the adjustment procedure.

3. Connect a standard signal generator through a 330- μf capacitor to point Q on the radio-frequency tuner and connect a vacuum-tube voltmeter across the diode load resistor R196.

4. Set the signal generator accurately to 28.25 megacycles.

5. Adjust adjacent channel sound trap slug for *minimum* reading on the vacuum-tube voltmeter.

6. With a normal picture and a properly tuned receiver, a slight readjustment of adjacent-channel sound-trap slug may be necessary in weak-signal areas to further minimize sound interference as viewed on the screen.

SEARS ROEBUCK

Chassis 100.107, -.111,
-.112, -.115, -.121

Improving sensitivity and sync stability.

Sensitivity and synchronizing stability of this chassis can be further improved by incorporating the changes indicated below. This modification has been incorporated in all models coded Series C.

1. Remove sound-trap coil L160 and 240- μf capacitor C162 from cathode circuit of first intermediate-frequency amplifier tube 6AU6.

2. Change resistor R161 in cathode circuit of 1st i-f amplifier from 270 ohms to 82 ohms and connect it to ground.

3. Connect new trap coil assembly, part No. 520220, into plate circuit

of 1st i-f amplifier. Insert the new trap coil in the hole previously occupied by the old coil.

4. Connect 3.3-megohm, $\frac{1}{2}$ -watt resistor from pin 1 to pin 6 of keyer automatic-gain control tube 6AU6 (6AG5 on chassis coded Series A).

5. Connect 3.3-megohm, $\frac{1}{2}$ -watt resistor between agc line and 120-volt B-plus supply.

6. The new trap coil should be aligned to the old trap frequency of 22.4 megacycles.

7. After completing this conversion, the fourth intermediate-frequency stage should be changed in frequency from 24.75 megacycles to 24.9 megacycles.

SEARS ROEBUCK

Chassis 100.107, -.111,
-.115, -.120, F209

Improving vertical stability in fringe areas (see Fig. 27).

To improve vertical stability and locking action in low-signal areas, several changes can be made in the above chassis. A portion of the circuit involved is shown in the figures.

The first circuit (part A) applies to the 100.107, -.111 and -.115 chassis numbers. This circuit was changed in the 100.120 chassis (part B) for better vertical and horizontal stability and improved noise immunity. The arrangement can be incorporated in any of the early sets if complaints are received.

For further improvement in this circuit and to minimize vertical drift, the following changes may be made in low-signal areas. Change the 1.8-k resistor R351, closest to the plate of the phase splitter, to 3.9 k, and the lower 1.8-k resistor R246 to

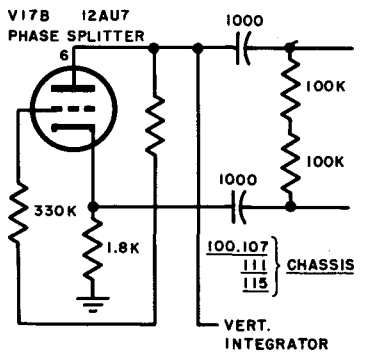

(A)

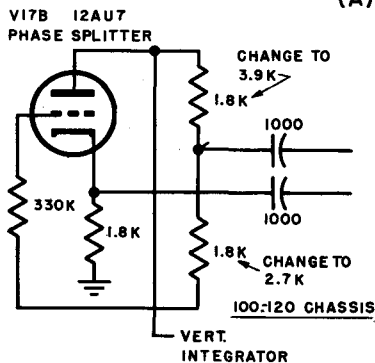

(B)

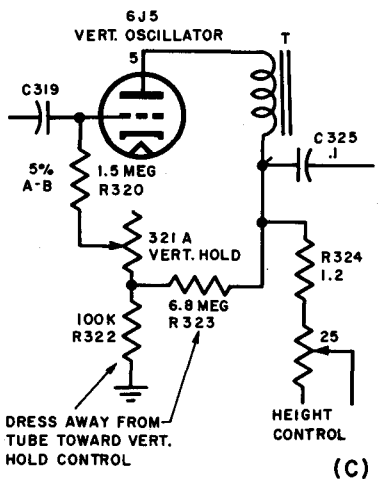

(C)

Fig. 27 — Sears Roebuck

2.7 k. This will increase the sync amplitude by about 40 percent.

To minimize drift in the vertical oscillator, change the 1.5-meg resistor R320 in the grid circuit to a 1.5-meg, Allen-Bradley, 5 percent resistor. Leave the lead attached to pin 5 on the 6J5 vertical-oscillator tube full length and place the resistor physically close to the vertical-hold control and as far as possible from the tube to keep away from any source of heat. Also, dress up and away from heat the 6.8-meg resistor R323 attached to one end of the hold control.

SEARS ROEBUCK

Chassis 100.107,
-111, -112

Width-coil failures.

The manufacturer experienced a small number of width-coil (part No. W508667) failures on the above models. The primary winding shorted to the secondary winding due to faulty insulation on coils received from their sources. When this occurred, the B-plus (350 volts) was connected to the automatic-gain-control line, the grids of the radio-frequency amplifier and the first three intermediate-frequency amplifier tubes and keyer-tube plate circuit. Any or all of these tubes may have been damaged by this high B-plus voltage.

It also may have applied 350 volts across the 100-k resistor in the automatic-gain-control delay circuit to ground and may have damaged this resistor. If this resistor opens, there is 350 volts on the two 200-volt bypass capacitors in the automatic-gain-control delay network. Any of the resistors or capacitors in the grid

circuits of these tubes controlled by the automatic gain control may have been damaged.

The usual symptoms observed on the picture tube or heard in the speaker are intermittent sound and picture or poor definition and sync stability due to the change in intermediate-frequency response.

SEARS ROEBUCK

Chassis 100.107,
-.111, -.121

Black bar at top of picture.

A black bar may appear at the top of the picture due to a-c ripple. This ripple is fed to the cathode of the picture tube via a .02- μ f capacitor (*C174* in chassis 100.107 and -.111, and *C231* in chassis 100.121) from the vertical yoke. The a-c ripple is caused by a weak 10- μ f, 600-volt filter capacitor which is connected to the 415-volt bus from the damper tube. This capacitor is *C224* in the 100.107 and -.111 chassis and *C287* in the 100.121 chassis.

Although the filter is defective, there is plenty of vertical sweep and there is a sawtooth at the plate of the vertical-output tube. There is, however, no sawtooth at the input to the vertical yoke. This appears only to be a sine-wave a-c voltage. At normal brightness, touching another filter across the defective one will blank out the picture and one might be deceived very easily.

SEARS ROEBUCK Chassis 100.107, -.112

Buzz reduction (see Fig. 28).

In the above models and others, there may be some video buzz due to the critical lead dress of certain circuits. If the receiver is properly aligned and the buzz still persists, check and correct the lead dress.

This buzz can be eliminated through careful lead dress of the offending parts. In particular, the yellow lead to the cathode of the keyer tube and the white wire to the grid of the same tube. Both leads are

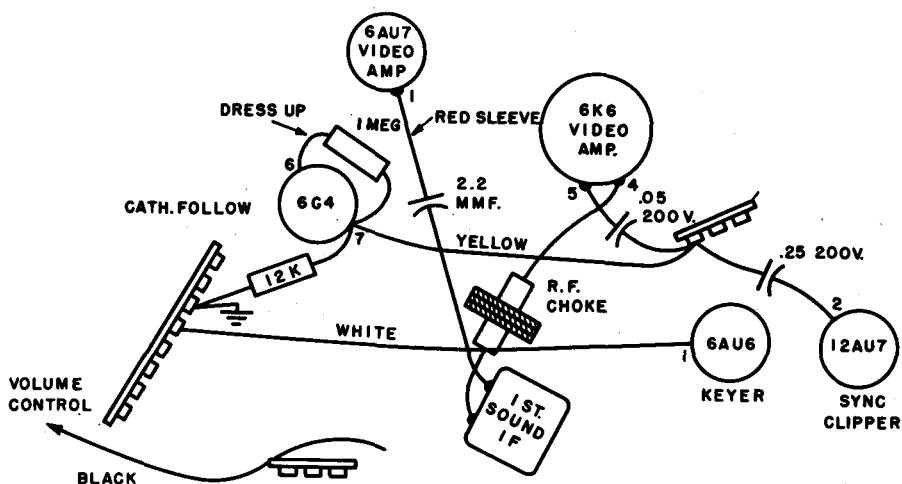

Fig. 28 — Sears Roebuck

heavy radiators of radio frequency. By locating a radio-frequency choke between these paralleled leads and the 2.2- μ f red-sleeved capacitor, the buzz is reduced to a minimum.

The procedure is as follows:

1. Unsolder the ground end of *R156*, a 12-k, 2-watt resistor from pin 7 of *V13*, 6C4 cathode follower. Resolder the grounded end to the mounting lug of the terminal strip as illustrated.

2. Dress *C11*, the red-sleeved 2.2- μ f sound-coupling capacitor from the first sound intermediate-frequency transformer to pin 1 of 6AU6, *V12* video amplifier, as close to the chassis as possible.

3. Unsolder choke *L15* from the 150-volt B+ supply and connect to pin 4 of 6K6, video amplifier *V14*, under the white and yellow wires. These wires should be dressed away from the chassis so that the choke falls between them and the 2.2- μ f capacitor in the red sleeve. The choke will then act as a shield between sound and video.

4. Dress up *C157*, .05- μ f, 200-volt capacitor from pin 5 of 6K6, *V14* video amplifier, to tie point on the terminal strip as illustrated. This point is also tied to pin 7 of 6C4, *V13*, by the yellow wire.

5. Dress up toward the high-voltage supply *C187*, .25- μ f, 200-volt capacitor from pin 2 of 12AU7, *V17* sync clipper, to same tie point as in step 4 of procedure.

6. The black lead from the volume control should be slipped under the corner of the terminal strip.

7. Adjust all of above for minimum buzz.

SEARS ROEBUCK Chassis 100.107 **Vertical instability and lack of height.**

A small but unknown quantity of the above television receivers was produced and shipped with vertical instability and some lack of vertical size and linearity. As soon as this difficulty was discovered, a check was made and it was found that the cathode-bias resistor of the vertical-output tube, part No. 276, which is supposed to be 560 ohms and is properly coded for 560 ohms, is actually of incorrect value. If insufficient vertical height is found, this resistor should be measured and if not 560 ohms, should be replaced.

Another resistor which is incorrectly color coded in some cases is part No. 269 in the vertical-oscillator plate section. The correct value for this part is 1.5 megohms and all the resistors used were coded to indicate 1.5 megohms. However, if the receiver fails to hold vertically after several hours of operation, this resistor should be checked and, if it does not measure 1.5 megohms, it should be replaced.

SEARS ROEBUCK

Chassis 100.120, -.121 **Unused channel squealing.**

Investigation of loud squealing on unused channels of some of the above television receivers has revealed this condition is due to half-frequency oscillation (approximately 7.5 kc) occurring in the horizontal oscillator during the time the synchronization signals are absent and the oscillator is free running.

This condition can be corrected by replacing the 5,600-ohm resistor

(R258) in the plate circuit, pin 2, of the 6SN7 horizontal-scanning multivibrator with a 3,900-ohm resistor and dressing the associated leads.

If this condition is present on other models, the same correction can be applied. However, in the earlier chassis a 12AU7 tube was used as the horizontal oscillator and the 5,600-ohm resistor was R203 from pin 6 of the 12AU7.

SEARS ROEBUCK Chassis 100.120
Improving sync stability.

This change, already made in later production, is incorporated in the chassis to improve vertical and horizontal sync stability.

1. Resistor R351 (1,800 ohms) is added in plate circuit of V17B (12AU7) phase splitter. The junction of resistor R246 (1,800 ohms) and capacitor C247 (1,000 $\mu\mu\text{f}$) was formerly connected directly to pin 6 of this tube.

2. Resistor R258 in plate circuit of V19 (6SN7GT) horizontal-scanning multivibrator stage is changed from 5,600 ohms to 3,900 ohms.

SEARS ROEBUCK Chassis 100.120
Reducing tube noise and
improving picture quality.

This change incorporated in later production, is used to decrease tube noise level and improve picture quality.

1. Resistor R161 in the cathode circuit of V7 (1st i-f amplifier) is from 82 ohms to 270 ohms.

2. Resistor R176 in grid circuit of V9 (6AU6) 3rd i-f amplifier stage is changed from 4,700 ohms to 8,200 ohms.

3. Resistor R183 in plate circuit of V9 (6AU6), 3rd i-f amplifier

stage, is changed from 8,200 ohms to 6,800 ohms.

4. Resistor R196 in plate circuit of V11A (6AL5) detector stage is changed from 6,800 ohms to 4,700 ohms.

In addition, the alignment frequency of the converter plate coil and 2nd i-f coil is changed from 26.3 mc to 26.1 mc. Voltages measured at certain tube-socket terminals on a chassis which includes the above modifications will differ from those shown in the service notes. New measurements are as follows:

Pin 7 of V7 (6AU6) is 1.5 volts

Pin 1 of V9 (6AU6) is .4 volts

SEARS ROEBUCK Chassis 100.120
Reducing ringing.

In order to reduce the ringing effect of the horizontal-sweep transformer and deflection yoke, which appears as white (or black) vertical lines on left side of picture screen, the following change, included in later production, is made:

1. Trap coil L354 is added in series with the high-side horizontal-yoke lead. The part number of this coil is W509615.

2. Capacitor C355 (.003 μf) is placed in shunt across coil L354.

3. Resistor R356 (680 ohms) is placed in shunt across coil L354.

SEARS ROEBUCK Chassis 100.120
Limiting picture-tube beam
current.

The following change is made to limit picture-tube beam current:

Connection to pin 10 of tube V15 (16TP4 or 16RP4) picture tube is changed from the 415-volt B+ boost bus to the 340-volt B+ bus.

Voltage measured at pin 10 of V15 (16TP4 or 16RP4) should now be 340 volts.

SEARS ROEBUCK

Chassis 100.208, -.209

Static discharge from mounting bolts and bezel.

There have been a few isolated reports of popping sounds in the speaker and/or very slight shock from speaker-mounting bolts and picture bezel or front-control cover when they are touched, such as a static charge from crossing a carpet. To correct this, add a wire from the cover assembly to picture-tube gold bezel bolt and from bezel to speaker frame. Attach a wire from speaker frame to the ground side of speaker voice coil. This will be done in future production.

SEARS ROEBUCK

Chassis 100.208, -.209

Eliminating shock hazard.

On some of the above chassis, it is possible for a user to come into contact with the B+ voltage bus on the focus control or other controls if he were to reach through the front trap door and reach beyond the bottom of the controls. To eliminate this possibility, the manufacturer has provided a fiber shield which can be attached to the sub-panel on which the controls are mounted. Whenever a complaint of this nature is received or whenever the chassis is removed from the cabinet for any reason, this shield (used in later production) should be added.

To install the shield, remove the nuts which hold the four controls to the assembly, position the shield

under the front assembly, and reinstall the control locking nuts. The part number of the shield is W520673.

SEARS ROEBUCK Chassis 100.208

Horizontal pulling.

Several reports have been received of horizontal pulling or, in some cases, low contrast and snowy pictures, particularly on the high-band channels. Investigation has disclosed that this condition is caused by a leaky neutralizing capacitor, part No. 405, a 2.2- μ f capacitor in the plate circuit of the r-f amplifier tube. In a strong- or moderate-signal area this capacitor may be clipped out of the circuit without any adverse effects. In a weak-signal area the capacitor must be replaced. If care is taken not to disturb any other circuits in the tuner and the exact replacement part is used, no realignment or other adjustment is necessary on this tuner. When measuring across this capacitor, there will be a leakage usually of 5 to 10 megohms. This has been brought about by a chemical change in the ceramic material used in the capacitor. All later production will have a different type of capacitor in this circuit.

SEARS ROEBUCK Chassis 100.208

Improved sync action.

To obtain better holding action when extreme impulse noise is not present, part No. 321, a 10-meg resistor connected from pin 4 of the sync-amplifier tube to B+ is removed. This change provides greater sync amplitude and better holding action. In the event of extreme lo-

cal impulse noise, the resistor should remain in the circuit.

SEARS ROEBUCK Chassis 100.208
Vertical rolling.

The type 6BL7 tube is used as a vertical-oscillator output tube in the above chassis. About 50 percent of these tubes may cause trouble such as vertical rolling. For the present, the only proven correction for vertical synchronizing troubles in sets using this tube is to replace the tube.

SEARS ROEBUCK Chassis 100.208
Increased fringe-area sync stability (see Fig. 29).

The following circuit changes should be incorporated into all the above chassis that are being oper-

ated in extreme fringe areas. These changes will result in greatly improved synchronizing stability under conditions of weak signal. Do not make this change on chassis located in strong- or moderate-signal areas.

1. Add a 10-megohm, 1/2-watt resistor from pin 4 of the 6SN7GT sync-amplifier tube to 140-volt B+ (see part (A) of the figure). This resistor is already included in some chassis.

2. Disconnect pin 6 of the 6AC7 video amplifier from 140-volt B+ and insert an 8,200-ohm, 1-watt resistor as shown in part (B) of the figure.

3. Add a 12,000-ohm, 1-watt resistor from pin 6 of the 6AC7 video amplifier to chassis ground.

4. Add a .25- μ f, 200-volt capacitor from pin 6 of the 6AC7 video-amplifier tube to ground.

SEARS ROEBUCK Chassis 100.499
Eliminating vertical jitter.

To eliminate a slight vertical unsteadiness or jitter which was present in a few receivers, the .005- μ f capacitor in the integrating circuit of the vertical oscillator is changed to .01- μ f. This change has already been made in later production.

SEARS ROEBUCK Chassis 100.499
Improving horizontal stability.

To improve the horizontal stability and eliminate all trace of jitter, a 1.3-ohm resistor is placed in series with the filament of the 6AL5 horizontal phase detector to lower the filament voltage and eliminate the effect of variance in tubes. This change has already been included in later production.

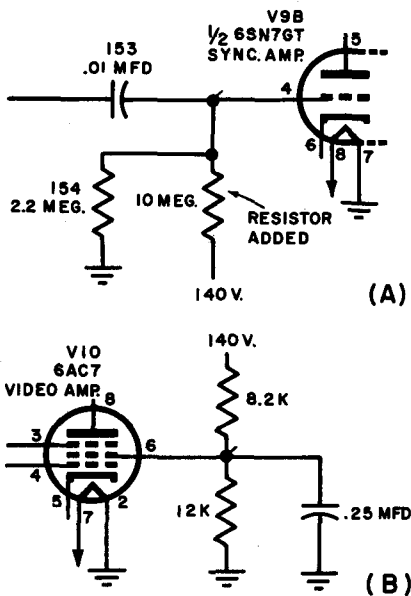

Fig. 29 — Sears Roebuck

SEARS ROEBUCK

Chassis 100.700-1
through -140

Horizontal jitter due to video overloading.

In strong-signal areas overloading may occur in the first video-amplifier circuit. To correct this condition the following two changes should be made:

1. Change *R69*, a 2.2-k, 1-watt resistor (in plate circuit of the first video-amplifier stage) to a 3.3-k, 1-watt resistor.

2. Change *C58*, a 390- μmf capacitor (in the cathode circuit, pin 8, of the second video amplifier) to 180 μmf in order to maintain proper video-amplifier response characteristics.

SEARS ROEBUCK

Chassis 101.846, -.854

High-voltage disabling.

Instructions in service notes for disabling the high-voltage power supply on the above models state that the ungrounded filament lead to the 7AF7 horizontal oscillator and discharge tube should be disconnected. Due to a recent change in the bias circuit for the 6BG6G horizontal-output tube, the removal of the 7AF7 filament lead results in removing all bias from the horizontal-output tube causing failure of the 6BG6G tube.

The factory is now recommending that the filament-supply voltage be removed from the 6BG6G horizontal-output tube to eliminate the high-voltage hazard. This filament-supply voltage can be removed without opening the high-voltage scanning box by disconnecting the brown lead which runs from the scanning box

to the filament choke on the main chassis.

Caution: Be sure that the shell of the picture tube is grounded when the second-anode lead is connected.

SEARS ROEBUCK

Chassis 101.846, -.854

Shock hazard at deflection yokes.

A limited number of the above receivers were shipped from the factory with loose deflection-yoke caps. This cap protects the high-voltage terminals of the deflection coil and it is important that it be securely fastened to the deflection yoke housing. A good grade of paper cement can be used to securely fasten the cap. It is recommended that all deflection-yoke caps be checked for proper bonding to the housing before servicing.

SEARS ROEBUCK

Chassis 101.846, -.854

Increasing horizontal size in low-line voltage areas.

There have been some reports of difficulty in obtaining sufficient scanning width on the model 8132 television receiver. This difficulty is experienced particularly in areas where the line voltage is slightly lower than normal. The factory has recommended the following procedure for increasing the scanning width.

Short out cathode bias resistor *R108* and bypass capacitor *C98* in the 6BG6 horizontal-amplifier circuit. Change the 6BG6 grid-leak resistor *R107* from 470,000 ohms to 330,000 ohms. These changes should increase the horizontal width from $\frac{3}{4}$ to 1 inch.

Another method of obtaining additional horizontal scanning on both models 8132 and 8133 is to replace the horizontal-scanning transformer *T11*, part No. 65441, with a new transformer *T11*, part No. 70155. When this is done, the cathode circuit of 6BG6G horizontal-output tube must be connected as shown in the service notes. Since some sets were produced at the factory with the changes outlined above included in their production, capacitor *C98* and resistor *R108* are missing. These parts must be inserted if the new *T11* is used.

SEARS ROEBUCK

Chassis 101.846, -.854 Low sensitivity in fringe areas.

For an undetermined period of time, the above models were produced with less than normal sensitivity. This was due to the fact that the alignment and checking equipment of the manufacturer had drifted and the drifting was unnoticed. The drifting caused a slight misalignment of all chassis affected. The result of the misalignment is a reduction of the sensitivity of the receiver by a sufficient amount to cause complaint in fringe areas.

Complete realignment of the receiver concerned is not recommended since it is not necessary. To restore these receivers to 100 percent performance, a slight retouching of the i-f trimmers on both the video and sound channels using the recommended test equipment is all that is necessary. Inasmuch as the bandwidth was not affected by the drifting of the factory's alignment equipment, this misalignment is not det-

rimental where the receiver is located in metropolitan areas or within approximately 15 miles of the transmitting stations.

The chassis produced during the period in which this misalignment occurred will have a serial number lower than BO8T-3378 on models 8133 and lower than BO9T-20500 on models 8132.

SEARS ROEBUCK Chassis 101.846 Installation of 4.5-mc trap (see Fig. 30).

Later production of the above chassis incorporates a 4.5-mc trap off the plate of the first video-amplifier tube 6AU6. This is necessary to

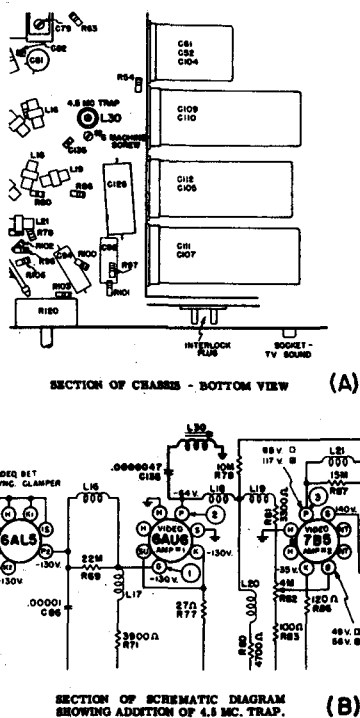

Fig. 30 - Sears Roebuck

remove the heterodyne beat caused by the 26.4-mc picture i-f signal at the video detector against the very low but still present 21.9-mc sound i-f signal which tends to pass through the sound traps when the receiver is slightly detuned. This beat will show up on the picture tube as sound bars or a small herringbone pattern across the entire scene.

To install this 4.5-mc trap, proceed as follows:

1. Place the chassis on the bench in an upside down position.

2. Remove the No. 6 machine screw from the chassis located midway between the 1st video-amplifier 6AU6 tube socket and capacitors C109 and C110 (see part (A) of the figure).

3. Install the trap coil (L30 part No. R70077) to the chassis by placing the screw through the hole in the coil bracket and replacing the screw into the chassis. Before tightening the screw, rotate the trap coil so that the side with the soldering lugs is facing the front of the chassis.

4. Tighten the machine screw.

5. Solder a wire to the coil lug nearest the chassis to ground.

6. Connect a 4.7- μ mf ceramic capacitor to the top lug on the trap coil and the plate (pin 2) of the 6AU6 1st video-amplifier tube. See part (B) of the figure for a section of the schematic diagram showing this addition.

After the trap is installed, it should be aligned as follows:

1. With the chassis completely adjusted and connected for operation, tune in a test pattern from a television station.

2. Turn the contrast control to its maximum position and the brightness control to a low level (so that contrast is still noticeable).

3. Detune the fine-tuning control so that sound bars just become visible. A 4.5-mc beat is now readily visible on the screen.

4. Rotate the 4.5-mc trap coil-adjustment screw counterclockwise to its full out position (about 1 inch of screw showing).

5. Turn the adjustment screw in (clockwise) until the 4.5-mc beat on the screen just disappears. Do not go beyond this point.

SEARS ROEBUCK Chassis 101.854 Replacement of rubber bumpers.

The original rubber bumpers used under the table-model television receiver proved to be inadequate upon actual use in customers' homes if the customer attempted to slide the set across a flat surface. The manufacturer changed in production to a different type bumper made of felt which will support the weight of the set and will not tend to twist or come off should the set be pushed across its mounting surface.

At the time the change-over was made in production, a paper bag having the new type felt bumpers was included in each package which contained a television set equipped with the rubber bumpers. These could be changed easily at the time the set was prepared for delivery. For the benefit of those who received the original rubber bumpers before the production change-over, the felt bumpers are available from the manufacturer under part No.

R67714. These should be ordered and the bumpers on this model changed in the field where the rubber type are found.

SEARS ROEBUCK

Chassis 101.865, -.866,
-.867, -.868

Preventing capacitor breakdown.

Capacitor *C92* (.01 μ f at 400 volts), connected between pins 3 and 5 on the 7AF7 horizontal-oscillator discharge tube, may fail prematurely and cause damage to other components. This capacitor should be replaced with a .01- μ f unit which is rated at 600 volts.

It is not necessary to remove the chassis from the cabinet to make this substitution. Simply remove the bottom plate from the cabinet on either the console or table models with the cabinet on the side or upside down on protective pads.

SEARS ROEBUCK

Chassis 101.865, -.866,
-.867, -.868

Low brightness and poor focus.

Poor focus or dim pictures may occur on the above chassis. Due to variation in design of horizontal-output transformers, the manufacturer, in some sets, reduced the voltage output of the high-voltage power supply by grounding one side of h-v filter capacitor *C102* instead of returning it to the high side of the secondary of the horizontal-output transformer *T11*. This reduction of the high voltage (about 800 volts) gave wider scan with certain horizontal-output transformers.

In some sets resistor *R147* (39,000-ohm resistor shunting the screen-grid

dropping resistors) was omitted in the screen-grid circuit of the 6BG6G horizontal-output tube. This resulted in lower screen voltage on the 6BG6G which also affected the horizontal scan.

In some localities under low-line voltage conditions the picture was too dim and it was difficult to get the correct focus. If you have any complaints in the future in regard to this condition, the grounded side of *C102* may be returned to transformer *T11* as in the original chassis and *R147* installed in its original position in the 6BG6G screen circuit. The high voltage will then be back to normal. If insufficient scan is experienced under these conditions, then the horizontal-output transformer will have to be replaced. Transformer No. 70155 is, in all probability, the only one that will require this replacement. There are two transformers currently used — No. 70930 and No. 70372, both of which will be satisfactory replacements where absolutely necessary.

SEARS ROEBUCK

Chassis 106 series

Reducing snow.

Broadly speaking, it can be said that there are three areas of reception — the prime-signal area of metropolitan areas, the secondary-signal area outside metropolitan areas, and the fringe area. In the secondary-signal area the agc voltage developed on the r-f amplifier grid will sometimes prevent the receiver from operating at maximum necessary gain and, therefore, the snow content appearing in the picture may seem excessive. By removing the agc voltage applied to the r-f amplifier grid, the

snow content in the picture may be reduced.

As indicated in the service notes, a white agc lead comes from the tuner unit and connects to the junction of *R147* and *C148*. This junction point is made on a terminal strip on the chassis near the socket of *V4*. This junction point supplies the agc voltage to the r-f amplifier grid. If this end of the white lead is clipped free from the junction point of *R147* and *C148*, and then soldered to a clear spot on the chassis (ground) nearby, the reduction of snow content in the picture will in many cases be apparent.

When the agc voltage is removed from the r-f amplifier grid in this manner, it must be remembered that the receiver could overload if taken into strong-signal areas. Therefore, if it would become necessary to operate the receiver on strong signals, the white lead would again have to be connected to the agc junction point.

For fringe-area reception no difference will be noticed with the lead grounded or connected to the agc point because in fringe areas there would be insufficient signal to develop agc voltage in the first place, so there would be no agc voltage to remove.

The agc junction point of *R147* and *C148* is accessible without removing the chassis from the cabinet in the wood-cabinet models. Turning the cabinet upside down carefully and removing the screen over the cut-out under *V4* will expose the junction point sufficiently to make the change.

SEARS ROEBUCK

Chassis 110 series

Hum or buzz.

It was found in some cases of high 60-cycle hum in the above chassis which utilize Hytron picture tubes (either Hytron or Silvertone brand-ed) that the cause is poor contact between the grounding spring and the outer aquadag. Investigation has shown that the binder used in the aquadag will, under certain conditions of humidity, form a chalky coating which prevents proper grounding. The correction in such cases is to carefully wash the area around and under the contact spring with a cloth moistened with water.

Caution: The set must be shut off and the high-voltage supply discharged when this is done. No other type picture tube should be washed in this manner because most standard aquadag coatings are water soluble and would be removed if washed.

After the area around the grounding spring has been washed and dried, it should be blackened by the careful application of a very soft pencil.

SEARS ROEBUCK

Chassis 110 series

Arcing around cap on h-v lead.

The cap on the high-voltage lead of the above sets has been held down to the picture tube by means of two pieces of Scotch tape. Under certain moisture conditions, arcing develops from the cap or Scotch tape to the aquadag of the picture tube. Investigation disclosed that due to the critical shortage of certain materials, rubber had been substituted on these caps for neoprene.

Wherever arcing exists, the best correction is to wash the area around the second-anode connector on the picture tube with soap and water, being particular to clean the well of the connector thoroughly. Wash the upper surface of the tube with clear water. Do not replace rubber cap. Later production does not come with the rubber cap surrounding the high-voltage anode.

SEARS ROEBUCK Chassis 110.499
Intercarrier buzz.

To minimize intercarrier buzz on the above television chassis, add a 1,500- μmf , 400-volt capacitor from pin 9, the plate, of the 6T8 first sound-amplifier tube to ground.

SEARS ROEBUCK Chassis 110.499
Improved interlace.

Capacitor *C45*, 4,700 μmf , has been changed from its position in series with vertical-oscillator transformer, *T4*, and pin 1 of the vertical-oscillator tube to a position in the low side of the vertical-oscillator transformer in series with *R53*, 8,200-ohm integrating resistor.

This change was made in later production to improve the interlace characteristics of the receiver and, therefore, improve the apparent focus. It is recommended that this change be made in the field in cases where good focus is difficult to obtain.

SEARS ROEBUCK Chassis 110.499
Increasing and centering range of vertical-hold control.

To widen the range of the vertical-hold control, a 1.2-megohm resistor is placed across the control

from the top center to the grid side. In addition to this, a 1.2-megohm resistor is placed in series with the vertical-hold control to center the control area in the mid-portion of the potentiometer range. These changes have already been made in later production runs of this chassis.

SEARS ROEBUCK Chassis 110.499
Improved horizontal linearity.

A linearity kit, available from the manufacturer (part No. H.L.#1), is provided to correct the horizontal linearity in these television receivers. It will, if properly installed, give nonlinearity of not greater than $\frac{1}{4}$ inch out of round as measured on the horizontal wedges in the test patterns. Sets having nonsymmetry to the extent of $\frac{1}{2}$ inch are within the approved tolerance for a set not having a linearity adjusting coil circuit. On all later production bearing chassis number 110.499-20, -21, -22, and -33, this linearity coil is incorporated.

This linearity change should be made only on sets wherein the linearity cannot be corrected by such means as changing the 6BG6G tube and/or the 6W4 tube and by adjusting horizontal-drive control or damper resistor tap on *R83*.

SEARS ROEBUCK Chassis 110.499
Intermittent horizontal hold.

When the above chassis fails to hold horizontally or operates intermittently, the first check should be of the hold control itself. The voltage across the potentiometer is sufficient to cause the graphite coating to become spotty if the control is normally in a fixed position. This

can be determined if the control is rotated slowly in either direction from its normal position. It may be possible to locate another point where the picture will hold, but this is only a temporary measure and will leave the control setting very critical. To insure positive operation, the horizontal-hold control should be replaced.

SEARS ROEBUCK Chassis 110.499
Reducing intercarrier buzz
(see Fig. 31).

The following method to reduce intercarrier buzz (see parts (A) and

(B) of the figure), is recommended for its extreme simplicity:

1. Add a $5\text{-}\mu\text{mf}$ ceramic capacitor of 250-volts rating or better coupling the primary and secondary of $T1$, sound take-off transformer. Be sure to keep the body of the capacitor at least $\frac{1}{2}$ inch from the winding of the transformer.

2. Clip and remove the 12,000-ohm resistor, $R26$, from pin 6 of 6AU6 ratio-detector driver tube to ground.

3. Change $C4$, a $1\text{-}\mu\text{f}$, 25-volt electrolytic capacitor from pin 2 of 6T8 to ground to a capacitor of between 1 and $5\ \mu\text{f}$ with a working-voltage rating of 50 volts.

4. Then attach the negative lead of a 20,000 ohm-per-volt meter from pin 2 to ground. Set the meter to the 50-volt range. Tune in a test pattern and adjust the primary of $T1$ (at the underside of the chassis) for a maximum voltage reading. This will tune very broadly. A voltage reading of 40 to 50 volts will be obtained in primary-signal areas. Listening to the audio, adjust $T1$, top side of chassis, for a null or low buzz level.

The second method, given below, is slightly more effective but is also more difficult mechanically (see part (C) of the figure):

1. Remove $L9$, the video peaking coil, and the 18,000-ohm resistor from the low side of $T1$ and connect them directly to pin 8, plate, of $V8$ (6AC7).

2. Attach a $5\text{-}\mu\text{mf}$ capacitor from pin 8 to the top side of the secondary of $T1$.

3. In addition, completely remove all wires from the primary of $T1$ and remove its slug.

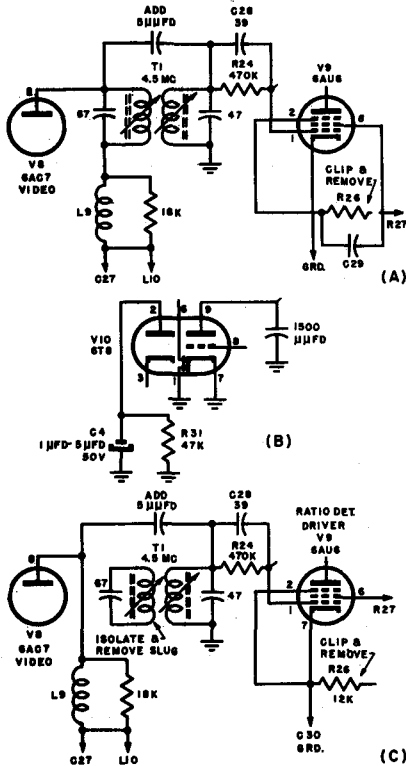

Fig. 31 — Sears Roebuck

4. Remove *R26* and change *C4* as described previously.

5. Then tune *T1* secondary (top side of chassis) for maximum sound with minimum buzz.

If the above circuit changes do not appreciably reduce the inter-carrier buzz, it is recommended that *T2*, ratio-detector transformer, be checked very carefully.

SEARS ROEBUCK

Chassis 110.700 series

Minimizing horizontal wiggle.

To minimize horizontal wiggle due to an overload condition, change the 2.7-k resistor in the cathode circuit of the horizontal multivibrator to 1.8 k. This is resistor *R58*. This change is already included in later production.

SEARS ROEBUCK

Chassis 110.700 series

Picture-controls interaction

(see Fig. 32).

The initial production of this chassis may have considerable interaction between picture controls. This is evidenced by a great change in linearity with an adjustment of the focus control, a change of the contrast control beyond the normal range, or under-normal adjustment of the brightness control.

To correct this condition, remove the yellow wire from pin 11, cathode, of the picture tube and remove the .05- μ f capacitor, *C28*, from the center arm of the brightness control. Attach a 270,000-ohm, 1-watt resistor to the center arm of the brightness control. Attach the other end of the resistor to the yellow wire from pin 11 and the .05- μ f capacitor. It will be noted that to obtain good

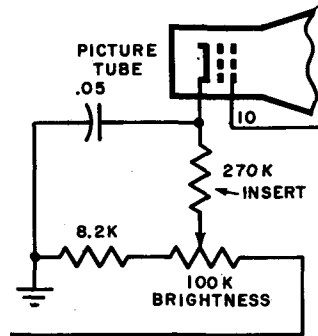

Fig. 32 — Sears Roebuck

linearity it may be necessary to adjust the linearity control from one end of the range to the other.

To set the brightness control correctly, turn the picture control fully counterclockwise. Advance the brightness control until the picture is barely visible in the background. Then advance the picture control for optimum viewing.

Note: The chassis need not be removed to make this change. This section is made accessible by removing the bottom of the cabinet screen.

SEARS ROEBUCK

Chassis 110.700 series

Vertical jitter.

Whenever a condition of vertical jitter exists and an air-core type vertical-oscillator transformer is used, short out *R45*, a 3.9-k peaking resistor in the grid circuit of the vertical-output tube.

SEARS ROEBUCK

Chassis 110.700 series

Horizontal instability.

To remove horizontal jitter and increase sync amplitude, change *R35*

(3.9-k resistor in sync-coupling circuit from *V13*, 12BH7 sync stage, to pin 2 of the horizontal phase detector) to 5.6 k. To remove a C- or S-twist on camera change, add a .25- μ f, 600-volt capacitor from the B+ end of *R18* to ground. Capacitor must be attached directly to *R18*, the 4.7-k, 2-watt video plate load resistor.

SEARS ROEBUCK

Chassis 110.700 series

High-voltage feedback.

In some of the above chassis the horizontal-output transformer may start squealing while the raster lines are increasing their spacing to as much as $\frac{1}{8}$ inch when an improper sawtooth voltage is fed to the grid of the 6BQ6.

This can be eliminated by careful lead dress of the red wire from the horizontal-deflection coils which causes this interference in the scan circuits.

SEARS ROEBUCK

Chassis 110.700 series

Retrace-line suppression.

The following circuits can be used to apply either horizontal- or vertical-retrace-line suppression. Vertical-retrace-line suppression will permit a higher level of brightness-control setting, particularly in weak-signal areas. It also gives the effect of better sensitivity.

The changes are as follows:

1. Lift the grounded side of *C28*, the .05- μ f capacitor connected to the cathode of the picture tube, and insert an 8.2-k, $\frac{1}{2}$ -watt resistor between the lifted lead and ground.

2. From the junction of *C28* and the new 8.2-k resistor, connect a .1-

μ f, 600-volt capacitor to the high side (green lead) of the vertical-output transformer.

3. From this same point (the green lead of the vertical-output transformer) add a .01- μ f, 600-volt capacitor to ground.

Horizontal-retrace-line suppression eliminates visible horizontal foldover in the picture, which is often described as veiling. This comes in from the left edge of the picture. With horizontal-retrace-line suppression, the setting of the horizontal afc control and the values of the capacitors and resistors in the horizontal-phasing circuit are less critical.

To apply horizontal-retrace-line suppression proceed as follows:

1. Lift the connection from pin 10, the accelerating anode of the picture tube, and attach in series with this line, a 470-k, 1-watt resistor.

2. From the junction of the 470-k resistor and pin 10 add a wire to the junction of *C47* and *C65*, the two 10- μ f capacitors in the horizontal-feedback circuit. These capacitors are attached through *R63* (82 ohms) to the grid of the horizontal-output tube (6BQ6GT).

SEARS ROEBUCK

Chassis 110.700 series

Improved vertical stability in fringe areas (see Fig. 33).

In fringe areas where the above chassis is more critical vertically and more susceptible to noise pulses, it is possible by making a few minor component changes to improve the noise immunity and vertical stability. The changes should be made as follows (see the figure):

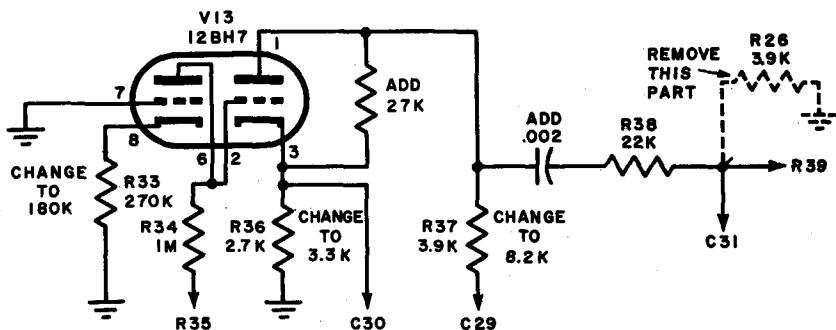

Fig. 33 — Sears Roebuck

1. Add a 27-k resistor from plate (pin 1) of *V13*, 12BH7, to the cathode (pin 3).

2. Change *R33*, a 270-k resistor from pin 8 of *V13* to ground, to 180 k.

3. Change *R36*, a 2.7-k resistor from pin 3 to ground, to 3.3 k.

4. Change *R37*, a 3.9-k resistor from pin 1 to B+, to 8.2 k.

5. Remove *R26*, a 3.9-k vertical integrating network resistor to ground.

6. Add a .002- μ f capacitor in series with the vertical integrating network from pin 1 of *V13* to *R38*. *R37* is to remain connected to pin 1.

SEARS ROEBUCK

Chassis 110.700 series Failure of vertical section of 12BH7.

A defective 12BH7 in the vertical section may damage the vertical-output plate-load resistor or change its value. If this occurs, it will be difficult or impossible to lock the vertical sweep and maintain good vertical size and linearity. Usually, the vertical-hold control will be at its extreme range (minimum resistance). Do not change the grid

resistor in series with the hold control unless there is obvious damage to it.

Early production had a 3,300-ohm, 1-watt plate-load resistor. This should be changed if available to two 3,300-ohm, 2-watt resistors in series or add one 3,300-ohm, 2-watt resistor in series in the plate-load circuit.

In all cases, a good 12BH7 should be used. Merely replacing 12BH7's will not permanently cure this trouble.

SEARS ROEBUCK

Chassis 110.700 series Failure of video section of 12BH7.

A defective 12BH7 in the video amplifier may have overloaded the 4,700-ohm, 2-watt plate-load resistor and reduced its value to as low as 1,000 ohms. This extreme case is apparent on visual examination of the resistor.

Picture-tube symptoms may be poor definition, characterized by smearing, and poor contrast or poor sync stability. A new 12BH7 may temporarily correct this complaint but is not a satisfactory or permanent cure. The 4,700-ohm, 2-watt

resistor should be checked and replaced if charred, overheated or undervalued by more than 10 percent.

SEARS ROEBUCK Chassis 110.700
Unstable horizontal phasing.

The condition of varying horizontal phasing on the above chassis with electrical centering is evidenced by the horizontal blanking bar moving across the screen when either the brightness or contrast control is adjusted. A leaky 25- μ f capacitor, C50, which is electrically across the horizontal-centering control, will cause the above described condition.

SEARS ROEBUCK Chassis 110.700
Horizontal jitter.

On a few of these sets the color socket was miswired. Pins 5 and 7 were interchanged. Pin 5 should go to R72, R80, C58, and cathode of second video-amplifier stage. Pin 7 should go to pin 3 of V13 (12BH7 phase splitter), R36, and C30.

This miswiring will produce a horizontal jitter that will be most apparent in low-signal areas.

SEARS ROEBUCK Chassis 110.700
Beads on retrace lines.

When vertical-oscillator transformer part No. P.B. 10125 (slug-type core) is used, beads may appear on the vertical-retrace lines if the leads are left too long and if the tuning slug is misadjusted. (Note: This transformer was used in later production and for replacement for part No. A-10106). The tuning is very broad and five to ten turns may be required. If beads cannot be eliminated by pushing excessive leads down in the transformer

can and by readjustment, add a .001- μ f, 600-volt paper capacitor from the high side of P4 (height control) to ground. A very slight loss of height is normal with the addition of this capacitor.

SEARS ROEBUCK Chassis 110.700
Hum and unwanted oscillations in picture.

To eliminate hum, shield the orange-colored lead from the television to the radio chassis. This can be done easily by disconnecting one end of the orange lead, slipping spiral shielding over the wire, and then grounding the sleeve. The orange lead in the radio runs from pin 7 of the radio plug and supplies the negative return of B-power.

To eliminate oscillation on low-band channels, add a .001- μ f, 600-volt capacitor from the white lead on the radio-television switch to ground, pin 6 of plug and switch. Also add a very short piece of heavy braid from television to radio chassis.

SEARS ROEBUCK

Chassis 110.700-120,
-140

Horizontal double pulsing.

There have been reports of horizontal double pulsing on the above mentioned chassis. Investigation discloses that this condition is caused by resistors being incorrectly marked or by resistors changing value with use.

The correction for this condition is to change R60, a 270-k resistor (from pin 6 of the 12BH7 horizontal-oscillator tube to B+) to 220k ohms. Do not change any other resistance value.

SEARS ROEBUCK

Chassis 110.700-1

Horizontal instability.

When the afc control is correctly adjusted in the above chassis, the picture will fall into horizontal sync instantly when changing from station to station and will be stable.

Sometimes this cannot be done without causing a fold-over on either the right or the left side of the picture. When this condition is present, it is an indication of unstable horizontal hold due to incorrect phasing from the transmitter. At certain adjustments of the afc control the picture will jitter violently.

To correct this condition, the 2.7-k phasing resistor *R52* (connected between one side of the width coil and the horizontal phase detector) will have to be increased to approximately 5 k if the fold-over is on the left side of the picture or decreased to about 1 k if the fold-over is on the right side of the picture.

SEARS ROEBUCK

Chassis 110.700-2

Noise due to lead-in mismatch.

Small black horizontal specks, particularly noticeable on the low band, may occur in the above model. This pick-up is caused by antenna lead-in mismatch in going through the band-change switch in the radio.

To effect a cure, disconnect the three-wire cable from the radio to the television (the center lead may be left connected) and connect the antenna lead-in directly to the television chassis. The built-in antenna can then be connected to the receiver terminal board for frequency-modulation reception.

SEARS ROEBUCK

Chassis 110.700-90 series

Horizontal jitter.

Capacitor *C38* (connected to pin 5 of horizontal phase detector) in the horizontal-phasing circuit is given as .01 μf . In some areas, a capacitor of this value may cause a slight horizontal jitter. This should be changed to .005 μf when the horizontal jitter is an area condition.

SEARS ROEBUCK

Chassis 110.700-900

Horizontal foldover.

To eliminate horizontal foldover on stations which transmit a sync pulse that has a very long horizontal retrace time, capacitor *C61* (.005- μf , 600-volt unit connected between ground and the junction of the two .005- μf capacitors in the afc feedback loop) is changed to .01 μf . This change has already been made in later production.

SEARS ROEBUCK

Chassis 110.702-10, -50

Poor horizontal stability.

Poor horizontal stability, low brilliance, and insufficient width are sometimes caused by a defective horizontal-oscillator coil (*L8*), part No. 28303. When this part is defective, the horizontal-output tube grid has a signal of about 40 volts peak-to-peak instead of 75 — 85 volts.

SEARS ROEBUCK

Chassis 132 series

Sync buzz.

Occasionally, due to slight misalignment in the intermediate frequency on the above chassis, buzz

will be heard in the sound. Slight adjustment of the ratio-detector transformer, *T101*, and the first intermediate-frequency transformer, *T103*, may eliminate the condition of buzz.

Use the following procedure:

1. Adjust the tuning for best picture. Note: Turn the tuning control clockwise until the picture begins to deteriorate and then turn it back carefully counterclockwise to the best picture settings. This locates the picture carrier properly on the intermediate-frequency response.

2. Adjust top of *T101* for minimum buzz, maintaining reasonably strong sound.

3. If buzz is still present, keep the tuning set as in step 1. Adjust the top of *T103* for minimum buzz, maintaining reasonably strong sound. Do not turn this slug more than one turn either way.

If more adjustment appears necessary, intermediate-frequency alignment with test instruments will be necessary. Caution should be exercised before adjustment to be certain that the buzz is not being transmitted by the station due to over-modulation.

SEARS ROEBUCK Chassis 132.889 Increasing life of horizontal-output tube (see Fig. 34).

Later production of the above chassis incorporate the accompanying circuit change to decrease the dissipation in the 6AV5GT horizontal-output tube and increase the life of this tube. In every case where a model 106 or 107 with the above chassis is returned for service, this change should be made. The following parts, available as a kit (part

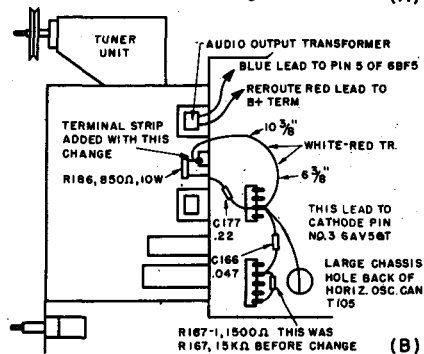
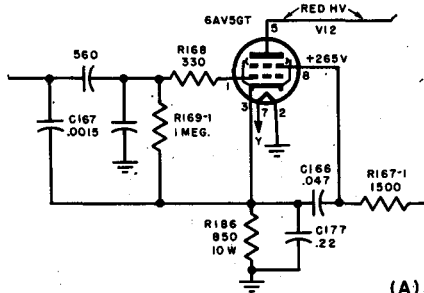

Fig. 34 — Sears Roebuck

No. N24033-1) from the manufacturer, are needed:

- 1 — 6AV5GT tube
- 1 — 850-ohm, 10-watt resistor
- 1 — 1,500-ohm, 10-watt resistor
- 1 — .22- μ f capacitor at 200 volts
- 1 — terminal strip
- 1 — 6/32 x 1/4 inch bolt with nut
- 1 — Lead, white-red tr 10 3/8 inches long
- 1 — Lead, white-red tr 6 3/8 inches long

The changes are as follows:

1. *R186*, 850-ohm, 10-watt resistor, is added between cathode and ground of 6AV5GT tube.
2. Ground side of *C166* (.047- μ f capacitor) rerouted to cathode of 6AV5GT.

3. *C177*, .22- μ f, 200-volt capacitor, added in cathode circuit of 6AV5GT tube.

4. *R167*, screen-grid resistor, changed to *R167-1*, 1,500 ohms at 10 watts.

5. Ground side of *C167* (.0015- μ f capacitor) rerouted to 6AV5GT cathode.

6. *R169-1*, grid resistor, has its ground side rerouted to 6AV5GT cathode.

SEARS ROEBUCK Chassis 132.889
Off-center picture.

If *C165*, a .47- μ f, 200-volt capacitor in the horizontal-output section between terminal 6 of the output transformer and terminal 3 of the deflection yoke, shorts, the current through the yoke is changed and the picture is shifted to the left.

SEARS ROEBUCK Chassis 132.889
Vertical wiggle due to yoke ringing.

To eliminate vertical wiggle at the beginning of the horizontal scanning lines of the above chassis, it will be necessary to change the value of *C161* (across one horizontal-yoke winding) from 47 μ f to any value between 39 and 60 μ f which will eliminate this wiggle.

SEARS ROEBUCK Chassis 132.889
Double pulsing in horizontal circuits.

There have been reports from the field that the above chassis may experience a condition known as "double pulsing." This is evidenced by a double picture overlapped at the center and usually out of sync. Under normal conditions it is nec-

essary to carefully adjust the horizontal frequency, horizontal lock range, horizontal drive, or horizontal waveshape in order to make the picture hold. Once in operation, the picture would remain, but if the set were turned off for a few minutes and then turned on again, the double pulsing would again appear.

To correct this condition, shunt the horizontal-locking range trimmer *C168B* in the first grid circuit of *V11A*, 6SN7GT horizontal oscillator, with a 470,000-ohm resistor.

SEARS ROEBUCK Chassis 132.889
Horizontal output transformer lead dress (see Fig. 35).

Improper grounding of the high-voltage leads in the above chassis can lead to high-voltage arcing which may result in a burn-up of the high-voltage compartment. To prevent this arcing, careful attention must be given to the lead dress. The correct method of dressing the leads is illustrated in the figure.

As further protection, the insulation on the various leads was changed later in production to fire-resistant Rulon and the spaghetti covering was changed to polyethylene.

Also, the outer periphery of the large diameter winding will now have two additional dips of black wax.

In the future the leads in the compartments will be kept as short as possible with any excess pulled through to the back side of the bakelite mounting base and then routed through an additional polyethylene sleeving.

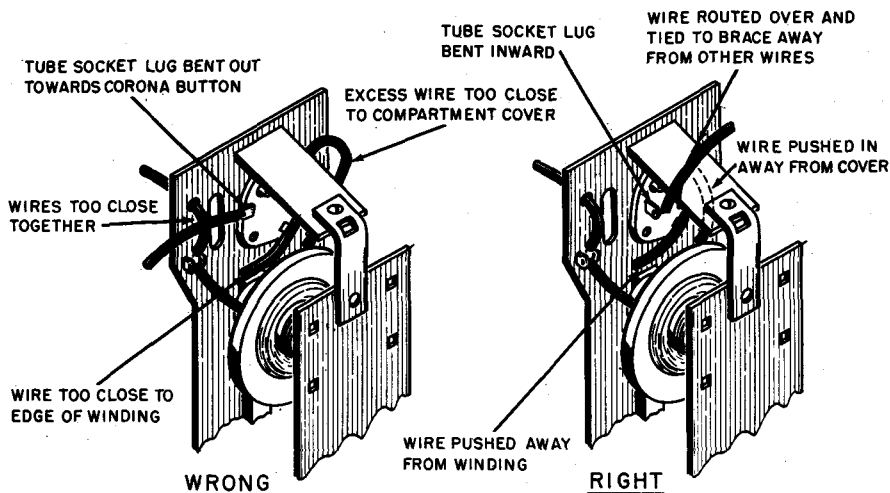

Fig. 35 — Sears Roebuck

SEARS ROEBUCK Chassis 132.889
Raster displaced vertically.

If the picture moves upward so that the blanking bar and 1 inch of top part of picture are visible in lower part of picture, it is usually an indication that the 5- μ f automatic-gain-control capacitor has opened or decreased in value. This is *C128* on the schematic.

If the raster drops and cannot be centered, the 30- μ f capacitor on the cold end of the vertical-output transformer may have changed value. This is *C120A* on the schematic.

SEARS ROEBUCK Chassis 132.890
Reducing 44-mc interference.

The following changes are made to reduce 44-mc outside r-f interference (from police stations, etc.):

1. *C150*, 100- μ f, 500-volt capacitor, is deleted from the grid circuit of *V5* (1st picture i-f amplifier).

2. *L121*, 44-mc tuned coil, is added between the grid (pin 1) of the 1st

picture i-f amplifier and the grid i-f lead coming from the tuner.

3. *C25*, 100- μ f, 500-volt capacitor, is added in the tuner between the plate, pin 2, of the mixer and the mixer plate coil *L7-1*.

4. *C26*, 150- μ f, 500-volt capacitor, is added in the tuner from the other side of the mixer plate coil to ground.

The above changes have already been made in later production.

SEARS ROEBUCK Chassis 132.890
Reducing vertical-sawtooth voltage and vertical-return time.

The following changes, already made later in production, reduce vertical-sawtooth voltage and vertical-return time:

1. *R161*, 2.2-meg, 10%, 1/2-watt resistor, is changed to 470k ohms, 10%, 1/2 watt. This resistor is across the grid winding of the vertical-oscillator transformer.

2. *R168*, 1,500-ohm, 5%, 1/2-watt resistor, is changed to 6,800 ohms, 5%, 1/2 watt. This resistor is the peaking resistor connected to the .047- μ f discharge capacitor *C161*.

3. *R206*, 22k-ohm, 10%, 1/2-watt resistor, is added between the output terminal of the integrating network and the .0047- μ f coupling capacitor to the vertical oscillator.

4. *C188*, .0015- μ f, 600-volt capacitor, is added across the grid winding of the vertical-oscillator transformer.

SEARS ROEBUCK Chassis 132.890
Reducing channel-7 interference.

Channel-7 interference may be caused by harmonic radiation of the i-f strip. To correct for radiation of fourth harmonic from the i-f strip being picked up by antenna lead-in, the following changes are made:

1. Lengthen 300-ohm lead connecting antenna terminals to tuner input by approximately eight inches.

2. Fasten antenna lead to pilaster in corner of cabinet to prevent any possibility of antenna lead falling near the i-f strip.

SEARS ROEBUCK Chassis 132.890
Improving interlace.

To improve interlace, peaking resistor *R168-1* (connected to .047- μ f vertical-oscillator discharge capacitor), which may have been changed in some production runs to 6,800 ohms, 1/2 watt, should be restored to its original value of 1,500 ohms, 5%, 1/2 watt.

SEARS ROEBUCK Chassis 132.890
Improving vertical stability.

The following change, made in later production, will alter the res-

onant frequency of the vertical-blocking-oscillator transformer, thereby improving vertical stability: *C188*, .0015- μ f, 20%, 600-volt capacitor used in later production across the grid winding of the transformer, is changed to 560 μ f, 10%, 500 volts.

SEARS ROEBUCK Chassis 132.890
Increasing picture height.

The following change, made in later production, will increase the voltage on the vertical-output transformer, thus increasing picture height: *R180*, 6,800-ohm, 10%, 2-watt resistor connected to red lead of vertical-output transformer, is changed to 4,000 ohms, 10%, 10 watts.

SEARS ROEBUCK Chassis 132.890
Replacement of vertical-output transformer.

When any of the changes described for this chassis under "Improving interlace," "Improving vertical stability," and "Increasing picture height" are made, the primary impedance of the vertical-output transformer is no longer correct. This transformer was changed in later production from part No. N23657-1 to N23657-2 (color marked yellow dot). When N23657-1 is used, a 15-ohm, 10%, 1/2-watt resistor is added from terminal 6 of the deflection yoke to electrolytic capacitor *C119A*. This capacitor is the 10- μ f unit connected to the red lead of the vertical-output transformer.

SEARS ROEBUCK

Chassis 132.890 series
Failure of h-v rectifier.

In the event of suspected failure of the h-v rectifier, make an ohm-

meter check between pins 2 and 7. Heat these pins with a soldering iron and recheck. The r-f supply tends to open the circuit of these tubes at the soldered joint in the tube pins.

SEARS ROEBUCK

Chassis 132.890 series Elimination of squeal and increase in width.

For added width and to eliminate 15,750-cycle squeal, carefully tighten bolt through horizontal-output transformer.

Added picture width may also be obtained by reducing the value of the cathode resistor of the 6CD6G. If a 300-ohm resistor is used, shunt it with a 500-ohm, 5-watt resistor or substitute a 200-ohm, 10-watt resistor.

SEARS ROEBUCK

Chassis 132.890 series Horizontal instability and foldover.

In the event that horizontal instability and foldover occur, check the adjustment of the afc circuit. A scope must be used for this check. Connect the scope through a 27k-ohm resistor for isolation to point C on the horizontal-oscillator transformer (T106). See the service notes for complete details.

If a flag-waving effect (top of picture pulling) occurs, check the above and the 5- μ f capacitor (C134) used as the automatic-gain-control filter. If C134 is open, video information gets into the agc line and causes erratic stability. A scope on the agc line will show if this is the trouble.

SEARS ROEBUCK

Chassis 132.890 series Improved vertical stability in noisy areas.

To improve vertical stability, R154 in sync-separator plate circuit is changed from 47k ohms to 15k ohms.

To improve noise impulse stability, add R205, 10-k, 1/2-watt resistor, in sync-signal line between R103, C105 (270 k and 270 μ f respectively) and the junction of R117, R118 (3,300- and 2,200-ohm resistors in plate circuit of video-output tube).

SEARS ROEBUCK

Chassis 132.890 series Focalizer and centering adjustment.

Set line voltage at 112 volts. Be sure focalizer is concentric around neck of tube and use a brass or nonmetallic screwdriver to adjust for focus.

If raster is displaced to one side, the deflection yoke may be magnetized or the picture tube may be defective. To correct for a magnetized yoke, disconnect horizontal coils. Momentarily connect yoke to about a 200-volt d-c source. Check to see if picture is moved in desired direction. If not, reverse connection to 200-volt d-c source. An instantaneous surge is all that is required.

Picture will also be moved if C165, a 47- μ f capacitor connected to terminal 3 of the horizontal-yoke winding is leaky or if R201, 24k-ohm resistor connected between this terminal and ground has changed value.

SEARS ROEBUCK

Chassis 132.890 series Audio buzz.

Remove *V1*, the 6AU6 4.5-mega-cycle intermediate-frequency amplifier. If buzz persists, it is probably synchronizing-signal buzz (if tuned to a station), picked up in *V3A*, 12AU7. *C112* (.0047- μ f ratio-detector and sync-clipper tube. Change 12AU7. *C112* (.0047- μ f ratio-detector output capacitor) or *C113* (.01- μ f coupling capacitor connected to 1st audio grid) may be too close to sync portion of 12AU7 (*V3B*).

See service notes for sound alignment or use following procedure:

Short out 4.5-megacycle trap *L120*. Connect signal generator to pin 4 of 6AC7 video-amplifier grid. Isolate generator with a 27k-ohm resistor in series with hot side of generator output. Make alignment network from two 100-k, $\frac{1}{2}$ -watt resistors. Attach network across load network (*R107*, *C111*, pin 7 of 6AL5) of the ratio detector. Attach meter to junction of the two 100k-ohm resistors. Peak *L101* (sound take-off) and *T101* (top, ratio-detector transformer). Reduce generator output so that no more than about 8 volts is measured on VTVM. Change ground end of network to junction of *R105*, *C109* and *R106* (82-ohm resistor, 330- μ f capacitor, and 27-k resistor in ratio-detector circuit) and check for equal amplitude of peaks by adjusting secondary of *T101* (bottom slug). If unequal, check *R105*, it may be 47 ohms and should be changed to 82 ohms. Tune *T101* bottom slug for midpoint deflection. Change meter back to pin 7 of *V2* (6AL5) to ground. Remove short on 4.5-mega-cycle trap and tune for minimum on VTVM. Air check.

For weak audio, change tubes. Check d-c resistance of *L101*. If it is greater than 1.25 ohms, change this coil. Also check values of *R112*, 160k ohms and *R113*, 180k ohms. These resistors, which form a voltage divider for grid bias of the audio-output tube, may have been interchanged.

C109 (330- μ f capacitor in the ratio-detector circuit) is also critical.

SEARS ROEBUCK Chassis 132.890 Improving a-m rejection of ratio detector.

To improve the balance of the ratio detector and increase a-m rejection, the following change, made in later production, may be incorporated. *R105*, 47-ohm, 10%, $\frac{1}{2}$ -watt resistor in the output circuit of the ratio detector, is increased to a value $\frac{1}{2}$ watt.

SEARS ROEBUCK Chassis 132.890 Increasing bandwidth of video amplifier.

The bandwidth of the video amplifier may be increased by means of the following changes, already made in later production:

1. *L106*, 250- μ h series-peaking coil in the video-detector circuit, is changed to 90 μ h.

2. *R129*, 47k-ohm, 10%, $\frac{1}{2}$ -watt resistor shunted across peaking coil *L106*, is changed to 10k ohm, 10%, $\frac{1}{2}$ watt.

3. *R124*, 10k-ohm, 10%, $\frac{1}{2}$ -watt resistor in parallel with the 300- μ h peaking coil connected to the plate of the video amplifier, is changed to 18k ohms, 10%, $\frac{1}{2}$ watt.

In addition to the above, a 4.5-mc trap is added to the plate circuit of the video-amplifier tube (between the 300- μ h peaking coil and the .1-

μ f coupling capacitor to the cathode of the picture tube) to keep the 4.5-mc beat from appearing in the picture.

SEARS ROEBUCK Chassis 132.890
Increasing width.

To increase the raster width, increase the drive voltage to the 6CD6 horizontal-output tube, by reducing *R181*, 91-k, 5%, 1-watt resistor in the boosted B+ circuit to the waveform-adjustment coil in the horizontal oscillator, to 62 k, 5%, 1 watt. This has already been done in later production.

SEARS ROEBUCK Chassis 132.890
Eliminating picture smear.

To eliminate picture smear, a separate ground wire from pin 1 of the video-amplifier tube is used. In early production, pins 1, 2, and 3 were wired to a common ground connection.

SEARS ROEBUCK Chassis 132.890
Reducing intermodulation buzz.

To reduce the effects of intermodulation within the combination sync and audio tube, *V3*, 12AU7, the grid resistor of the audio section *R109*, 10 meg, is changed to *R109-1*, 470k ohms. Also, cathode bias is added to *V3A* by adding *R202*, 3,300 ohms and cathode bypass capacitor *C185*, 5 μ f. These modifications have already been made in later production runs.

SEARS ROEBUCK Chassis 132.890
Reducing 4.5-mc beat in picture.

To reduce 4.5-mc herringbone in the picture, a special shielded lead with a ground at both ends is

added from the output of the ratio detector to the phono switch.

SEARS ROEBUCK Chassis 132.890
Improving interlace.

To improve interlace the following changes, made in later production, may be incorporated:

1. Add a tube shield for the vertical oscillator, *V12*, to reduce coupling from the horizontal oscillator.

2. Insert filter resistor *R204*, 100 ohms at 2 $\frac{1}{2}$ watts, between pin 3 of the color-converter socket and terminal 6 of the horizontal-output transformer. Also add *C186*, .1- μ f capacitor between terminal 6 and ground.

SEARS ROEBUCK Chassis 132.890
Channel-switch shaft slippage.

Several reports have been received that the channel-switch shaft slips in relation to the transfer cam. This results in inability to switch bands and poor or erratic operation due to poor contact of the transfer switch.

Check this by manually operating the transfer switch and observe if there is slippage of the channel-switch shaft when the transfer cam is held. (This part was changed early in production and will not be a general complaint.)

Order a new shaft assembly under part No. N24223-2 from the manufacturer. The directions for installing and restringing the dial cord are included with the shaft assembly.

SEARS ROEBUCK

Chassis 478 series
Reduction of buzz (see Fig. 36).

A study of buzz conditions in the above models has revealed the

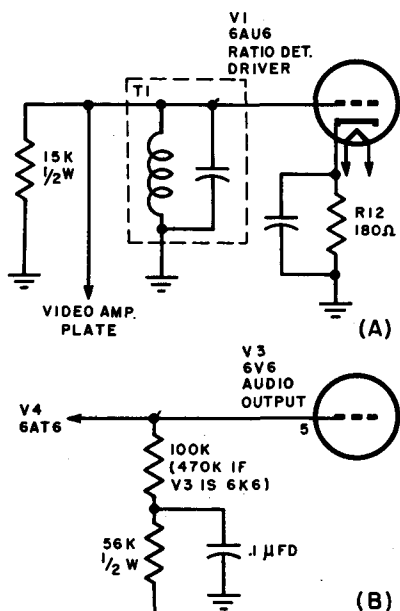

Fig. 36 — Sears Roebuck

two dominant causes to be inter-carrier buzz and audio pick-up of vertical-sweep or sync pulses.

The suggested cure for inter-carrier buzz is effected by adding a 15,000-ohm, $\frac{1}{2}$ -watt resistor from the 4.5-megacycle sound take-off trap to ground and changing the cathode resistor, R_{12} , of the ratio-detector driver, V_1 (6AU6), from 100 to 180 ohms. See part (A) of the figure.

The primary of the ratio-detector transformer should then be realigned.

The buzz from audio pick-up of vertical-sweep or sync pulses can be eliminated by adding a 56,000-ohm, $\frac{1}{2}$ -watt resistor between the 100,000-ohm resistor from pin 5 of the audio-output tube, V_3 (6V6GT), and the —7 volts supply. A .1- μ f capacitor should be placed from the junction of these two resistors to ground. If

the audio-output tube is a 6K6, then use a 100,000-ohm resistor instead of the 56,000-ohm resistor illustrated in part (B) of the figure.

SEARS ROEBUCK

Chassis 478 series
Horizontal drift (see Fig. 37).

There are two basic afc circuits used in the above series. Type 1 as shown in part (A) of the figure and used on 166-1166 is a syncroguide having a horizontal-oscillator transformer with a tertiary winding.

The capacitors indicated by M on the circuit diagram are molded-type capacitors. Units in these locations are quite critical due to heat and humidity changes. In the event of horizontal drift, these should be checked with a capacitor checker for leakage and replaced only with molded-type capacitors. The numbers indicate the sequence in which all of the capacitors should be checked. They are numbered in the order in which they may be expected to fail.

The second type circuit (see part (B) of the figure) used in model 110 and others does not have a tertiary winding but uses a temperature-compensating resistor as shown.

For drift in this circuit, check the 30-k temperature-compensating resistor. It should be placed parallel to and $\frac{3}{8}$ to $\frac{1}{2}$ inch away from the power transformer. Check the numbered capacitors in the order indicated for leakage and replace only with molded capacitors. The .002- μ f input capacitor to sync-guide grid is especially critical. Leakage of 1 to 5 megohms in any of the above capacitors can cause horizontal drift.

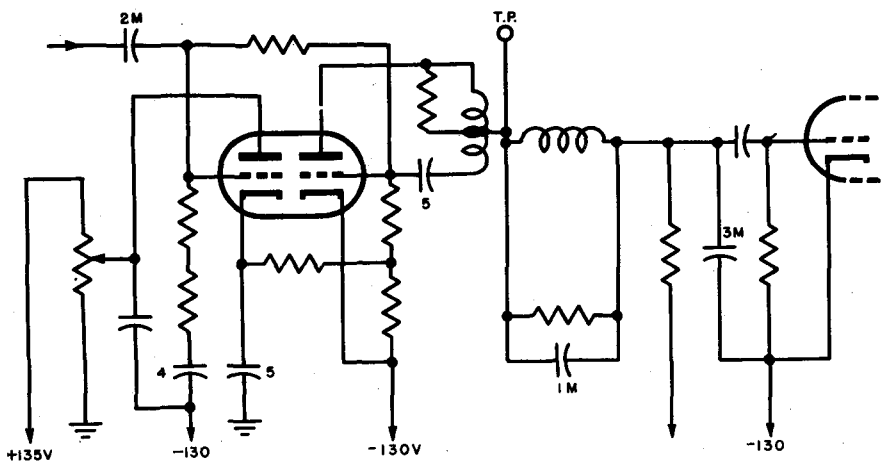

(A)

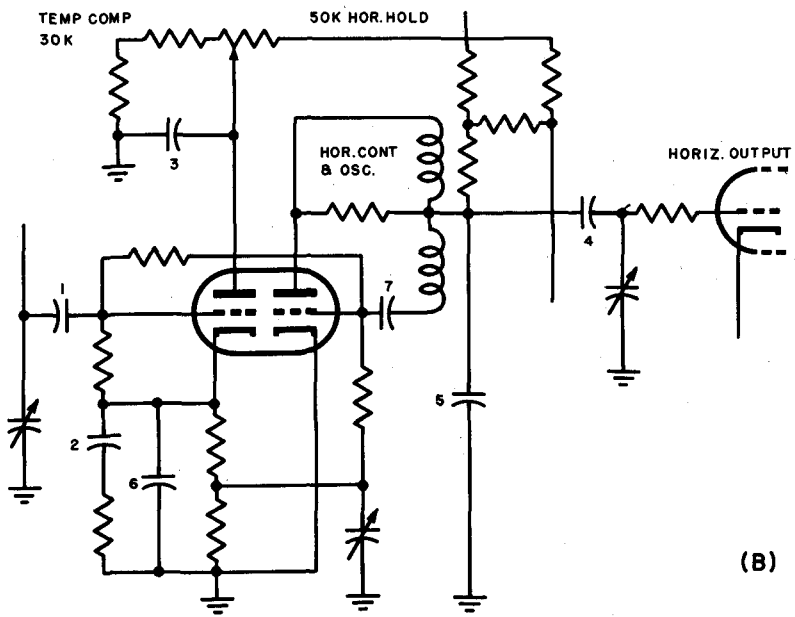

(B)

Fig. 37 - Sears Roebuck

SEARS ROEBUCK Chassis 478.303
Vertical bounce or flicker due to line-voltage changes.

To cure vertical bounce or flicker, in areas where the a-c line fluctuates with starting of refrigerators, etc., proceed as follows. From the junction of C64 (.25- μ f capacitor), R100 (56-k resistor), and center arm of R66 (height control), connect a 150-k, 2-watt resistor to ground. Then connect the unused 10- μ f, 475-volt section of the filter block to this junction.

SEARS ROEBUCK Chassis 478.319
Reduction of buzz.

Some early production receivers had the plate of the 6AT6 connected directly to the +235 volt source. It was found that by disconnecting R76, a 390-k resistor in chassis 478.319 (or R21, a 330-k resistor in chassis 478.313) from the +235 volt source and reconnecting it to the screen of the audio-output tube, pin 4 6K6, or to the +140 volt source which is also well filtered, the buzz could be eliminated.

SEARS ROEBUCK Chassis 478.319
Audio buzz.

After several months of operation, an audio buzz may become evident in the above chassis. This buzz is not to be confused with that from a defective speaker.

To prevent this audio pick-up, remove the grounded side of the .01- μ f capacitor C56 from pin 6 of V14, the 6AU6 4.5-megacycle amplifier, and reground it to a convenient point approximately 180 degrees from its present ground point. This

capacitor in early production was wired across the tube socket.

SEARS ROEBUCK

Chassis 478.321,
-.339, -.361

Abrupt contrast-control action accompanied by intercarrier buzz and unstable sync.

Some of the above receivers may have abrupt contrast-control action accompanied by intercarrier buzz and unstable sync. The remedy for these complaints is to remove the short across the 1,500-ohm resistor located on the color plug and substitute a resistor having a value of between 300 and 1,000 ohms. Select the actual value for best contrast-control action in your area.

To further improve sync stability change R34, a 3,300-ohm resistor in the cathode circuit of the sync amplifies, to 6,600 ohms.

SEARS ROEBUCK Chassis 478.338
Jagged or pie-crust picture.

To prevent parasitic oscillation which causes this jagged pie-crust like appearance, the manufacturer uses a parasitic-suppressor coil around the plate lead of the horizontal-output tube in the above model. One end of the coil is grounded while the other end floats.

In shipment, this coil may slip away from the optimum point which generally falls closer to the plate cap. Adjustment is made by moving the coil back or forth along the plate lead until the picture is no longer ragged.

SEARS ROEBUCK Chassis 478.338
Hum pick-up.

After several weeks of operation some console combinations became more susceptible to 60-cycle a-c pick-up. This pick-up can be traced to the lead from the tv-am-fm-phonoswitch to the audio input of the am-fm chassis. It currently passes next to the SPST a-c switch located on the end of the selector switch. By pushing this lead under the selector switch as far to the front as possible, the hum can be eliminated. An additional source of bad a-c hum in the television position is poor grounding in the socket of the 6T8: Soldering a wire from the tube-socket ground post to chassis eliminates the hum.

SEARS ROEBUCK Chassis 478.338
Insufficient width in low-line voltage areas.

Some of the above receivers may have inadequate width, especially if the line voltage is on the low side.

If a 100k-ohm resistor is not in series with the high-voltage lead, add one between the cathode of the 1B3GT and the high-voltage lead. In addition, the 6BQ6GT should be checked and the linearity coil adjusted.

On some of these receivers a few turns of high-voltage insulation wire have been wrapped around the plate lead of the 6BQ6. One end of this lead is grounded. This adds capacitance to the circuit which tends to make the picture wider; it also affects the retrace time so caution should be used or foldover may occur.

Do not lower the value of the screen resistor *R96* (3,000 ohms) of the 6BQ6 or the dissipation rating

of the tube will be exceeded and lead to short tube life.

SEARS ROEBUCK

Chassis 478.339, -.361
Picture smearing in hot, humid areas.

For smearing, particularly in hot, humid areas, check *R48* and *R49*. These resistors are 6,800-ohm, 2-watt units connected between the -130 volt bus and one side of the picture control, and between the -130 volt bus and the cathode circuit of the video amplifier. If the value of these resistors has changed, replace with 6,800-ohm, 4-watt resistors.

Also check the 150-ma selenium rectifier. It should be a blue, wide spaced, Sarkes-Tarzian type.

SEARS ROEBUCK

Chassis 478.339, -.361
Vertical-oscillator drift.

To reduce vertical-oscillator drift, check *R64*, a 560-ohm, 1/2-watt resistor in the grid circuit of the vertical-oscillator tube. Replace with a 560-ohm, 1-watt resistor.

SEARS ROEBUCK

Chassis 478.339B, -.361A, -.375, -.376
Low sensitivity.

Low sensitivity may occur in the above chassis with GI tuners. Due to the excessive vibration in shipment the end turn on *T301*, antenna-input coil, may have shorted to the adjacent turn, or *L308*, high-band interstage coil, may have shorted to the adjacent metal shield. To correct this, remove tuner cover and

carefully separate last two turns of T301 about 1/64 to 1/32 of an inch. Use a sharp nonmetallic tool or piece of paper. Move L308 about 1/64 to 1/32 of an inch from shield in a similar manner. Do not move turns or coil more than 1/32 of an inch or tuner operation may be seriously affected. This notice applies only if coil or turns have moved in transit.

SEARS ROEBUCK

Chassis 528.630,
-.631, -.632

H-v rectifier filament lead arcing.

It is possible, especially on earlier television models with the above chassis, for an arcing to occur from the 1B3 filament lead to the core of the horizontal-output transformer. The earliest sets had only a white plastic sleeve as insulation. Starting with some of chassis 630, and all of the 631 and 632 produced prior to March 10, 1952, an extra sleeve of Temflex, a reddish insulating tubing, was slipped over the white plastic insulation to prevent arcing.

Later production used a silicone sleeving, which is tan in color, as the main insulating sleeving on this lead. The Temflex sleeve is still used over the new silicone tubing as further insurance against arcing.

A warning should be noted by all servicemen that this particular filament lead is not ordinary copper wire as in other television receivers. The wire in this filament lead is special resistance wire which makes the addition of a filament-dropping resistor for the 1B3 filament unnecessary.

Some of the previous troubles on this part have been due to the heat

developed in this resistance wire which causes the plastic insulation to become soft so that the wire was able to press through and arc through the remaining thin wall of insulating material. In correcting this condition, obtain from the manufacturer the new silicone insulating sleeving and apply it to the 1B3 filament winding using the original filament resistance wire. Any other method of correcting this fault is likely to lead to other difficulties and the above should be followed carefully.

The insulated high-voltage filament lead for the horizontal-output transformer can be ordered from the manufacturer under part No. 84-692 (part of 80-265 horizontal-output transformer). The early production of these transformers arced through from the high-voltage filament lead to the core of the high-voltage transformer. Later production and the replaced lead assembly was made with a new high-temperature material which should completely eliminate any further arc-through of this part.

SEARS ROEBUCK

Chassis 528.630,
-.631, -.632

H-v fuse replacement.

Early production of the above chassis was shipped with a .125-amp fuse in the high-voltage circuit. Later .125-amp Slo-blo fuses were used. Still later production used .025-amp fuses, and it is recommended that all sets be so changed whenever a service call is made for any reason. The fuse is located in the high-voltage compartment.

SEARS ROEBUCK

Chassis 528.630, -.631

Horizontal nonlinearity.

To correct horizontal nonlinearity on the above mentioned chassis, the following procedure should be used:

1. Short out *R68*, a 47-ohm, 1-watt cathode resistor of the horizontal-output tube.

2. Change *C48*, coupling capacitor from the horizontal oscillator to the output stage, from 390 $\mu\mu\text{f}$ to 180 $\mu\mu\text{f}$.

3. Change *R64*, a 10k-ohm, $\frac{1}{2}$ -watt resistor on pin 5 of *V13* (the type 6SN7 horizontal-oscillator stage) to a 1,000-ohm, $\frac{1}{2}$ -watt resistor.

4. On chassis 528.630 and .630-1 only, change *C47* discharge capacitor in plate circuit of horizontal oscillator, from 470 $\mu\mu\text{f}$ to 390 $\mu\mu\text{f}$. The 390- $\mu\mu\text{f}$ capacitor removed from *C48* position above may be used.

If these changes do not correct the crushing on the right side of the picture, it is necessary in some sets to change the horizontal-output transformer. A new type transformer with a different core and winding changes is used in later production.

SEARS ROEBUCK

Chassis 528.630, -.631

Horizontal nonlinearity.

On this set there have been reports of unsatisfactory horizontal linearity. An example is crushing on the right-hand edge of the picture tube. To correct this condition on these chassis, use the horizontal-drive control in conjunction with the horizontal-linearity control. Also, overscan the picture about one-half inch on each side.

This adjustment of the horizontal-drive control may throw the set out of horizontal synchronization and, therefore, it will be necessary to readjust the horizontal afc control. The circuit constants are such that you cannot do any damage to the horizontal-output tube or its circuits by readjustment of the horizontal-drive control. It is possible by reducing the horizontal drive considerably beneath the point which produces the white drive line, that good linearity can be obtained on these receivers.

SEARS ROEBUCK

Chassis 528.630, -.631

Horizontal instability.

There have been several reports on this receiver of the horizontal afc acting as if the phase detector had been removed from the socket. The horizontal blanking bar would drift back and forth across the screen or the picture would go out of horizontal synchronization for no apparent reason. This generally became more noticeable as the receiver warmed up.

To correct this condition, check and replace, if necessary, *R51*, a 15k, $\frac{1}{2}$ -watt resistor in series with pins 5 and 7 of *V10* (6AL5 phase-detector tube) and the comparison voltage winding on the horizontal-output transformer. This lead may or may not be a red wire. When replacing this resistor, be sure to use a 15k, 1 watt resistor.

SEARS ROEBUCK Chassis 528.630

Vertical stretching and collapsing.

In a very limited production of this chassis a zinc-plated chassis was

used. This can be readily identified by its bright, silvery appearance as contrasted to other productions which were copper plated.

On a portion of one day's production it is possible that the grounds on electrolytic filter capacitors *C6*, *C26*, *C42*, *C44*, and *C49* may not be adequate. As soon as this condition was discovered, on all other zinc-plated chassis a common wire was run from point to point.

Whenever one of these chassis is in the shop for vertical difficulties, check for this condition, scrape and clean the chassis and resolder these connections.

SEARS ROEBUCK Chassis 528.630 Preventing capacitor breakdown.

Reports have shown that certain capacitors in the above chassis have failed in excessive quantities. In order to reduce customer complaints and service expense, it is recommended that these components be changed in all sets. Remove the bottom screen (it is not necessary to remove the chassis from the cabinet) and inspect and change the following parts:

1. Capacitors *C51* (.02 μf , 600 volts) and *C52* (.05 μf , 600 volts) may be branded "Chicago" or "Grey Tiger." These capacitors are connected to both ends of the horizontal-linearity coil. If branded "Chicago" (Chicago Condenser Company), they should be changed to 1,000-volt rated capacitors.

2. If capacitor *C27* (.2 μf , 600 volts) is branded "Chicago" it should be changed to a .22 μf , 600-volt molded type. This capacitor is

connected between ground and the junction of *R62* (270 k) and *R63* (56 k) in the plate circuit (pin 5) of the horizontal oscillator.

3. Capacitor *C55* (8 μf , 500 volts), which is now connected between the low side of the height control and ground, should be returned to B+ 150 volts (pin 6 screen of 6CB6 3rd i-f amplifier) to reduce the voltage appearing across it.

SEARS ROEBUCK Chassis 528.631 Removal of tuner cover (see Fig. 38).

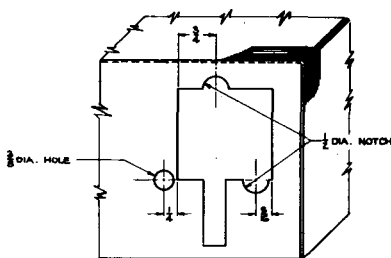

Fig. 38 — Sears Roebuck

The radio-frequency tuner used with this receiver has a bottom cover plate. The cover plate is attached to the tuner at the rear by two tabs which fit into slots in the back apron of the tuner. At the front, it is held in place by two screws which fasten to threaded holes in the front apron of the tuner.

To take off the bottom cover, remove the two screws securing it at the front, pull down slightly at the front, then slide backward to disengage the tabs and the cover will come off. It is not necessary to remove the tuner from the chassis to take the bottom cover off.

To facilitate removal, two screwdriver access holes have been provided in the front apron of the receiver chassis. Insert a screwdriver through these holes and proceed as above. It is necessary to remove the V-shaped shaft supporting bracket first. This bracket is fastened to the chassis by means of two self-tapping screws.

Unfortunately the utility of the screwdriver access holes was not realized at the beginning of production and some chassis were made without them. Servicemen in the field will find it more practical to drill the holes in such chassis, than to remove the tuner from the chassis to get the bottom cover off each time the tuner is serviced.

The data for the location of these access holes is given in the figure. The third hole shown in the illustration (at the top) permits removal of the screw which fastens the fine-tuning ground plate in place.

Tuners in later production do not have screws at the front to fasten the bottom cover. Instead, two dimples (detent bumps) are stamped into the bottom cover at the same position that the screw holes occupy in the earlier model tuners. These dimples engage matching holes in the front apron of the tuner chassis.

To remove this type of bottom cover, press down on the front edge with a screwdriver until the dimples are disengaged. Otherwise, removal is the same as before.

SEARS ROEBUCK Chassis 549.100 **Buzz reduction.**

The most frequent cause of buzz in the above model is from radiation

of the lead from the grid of the vertical oscillator to the vertical-hold control. Because of the chassis location of these parts, it was necessary to run this lead parallel to the audio circuits which resulted in this buzz pick-up. The lead dress providing best isolation would be that of running the lead from the vertical oscillator over the top of the chassis and then down again to the vertical-hold control. This will minimize, if not completely eliminate, the buzz. To determine whether all the buzz from the oscillator source of interference has been removed, either disable the vertical-output stage by disconnecting the grid feed or remove the tube if a separate stage is used as in the 19-inch model.

A secondary cause of vertical buzz stems from the retrace-suppressor circuit. The lead supplying the vertical-blanking pulse to the cathode of the picture tube radiates part of this pulse. The circuit from the vertical-deflection coil passes through *R136*, a 4,700-ohm resistor, *C118*, a .05- μ f capacitor, and then to the cathode of the picture tube where it feeds a portion of the large pulse developed during retrace.

On most receivers this lead passes very close to *R193*, coupling some of this pulse to the resistor which places it in the audio circuit. Re-dressing the lead at this point away from *R193* and its terminal board will stop all traces of buzz.

SEARS ROEBUCK

Chassis 549.100 series
Vertical picture shrinkage.

Over a long period of time there have been scattered reports of

vertical picture shrinkage (called "creeping" by some) on a series of the above television chassis. The complaint is described as follows: Picture okay when set is first turned on. After one to three hours use, the picture shrinks vertically, mostly at the bottom, failing by $\frac{1}{2}$ inch to $1\frac{1}{2}$ inches in filling the mask opening.

An extensive investigation of this problem has been made and shows that there is no one single cure that is effective in all cases. The following parts should be checked and adjustments made:

1. Weak 6SN7GT vertical-output tube.

2. Weak 5U4G rectifier tube. C147, C148 filter capacitors may have decreased in value or become leaky.

3. Weak 6J5GT vertical-oscillator tube.

4. Weak 6BQ6GT horizontal-output tube (source of vertical plate voltage).

5. Weak 6W4GT damper tube (source of B+ boost voltage).

6. Readjust horizontal drive for just under overdrive position (white line or minimum of -20 volts at grid of 6BQ6GT). Cathode voltage should be about 9 or 10 volts.

7. Check C129, .25- μ f, 600-volt capacitor connected to grid of vertical amplifier, for leakage. A d-c voltage greater than about .1-volt positive on grid (pins 1 and 4) of 6SN7 vertical-output tube is usually due to capacitor leakage. Replace with good quality molded capacitor if leaky.

8. If there is low-line voltage, substitute type 6BL7GT for 6SN7GT in vertical-output stage.

9. Adjust height and linearity for slight ($\frac{3}{8}$ inch) overscan so normal shrinkage will not show on picture after warmup.

10. Change value of R149 (connected to vertical-linearity control) from 4,700 ohms to 3,300 ohms. Change value of R147 (connected to pin 4 of vertical-output tube) from 2.2 megohms to 3.3 megohms.

11. Yoke may have wire-wound core. Later type has ceramic-iron core for greater efficiency and should be tried. Part number is M53C195.

12. Vertical-output transformer may be defective and change characteristics with heat. Substitute a new transformer as a check.

13. Whenever these receivers are serviced, be sure that adequate ventilation is provided especially around the high-voltage doghouse and the underside of the chassis.

SEARS ROEBUCK

Chassis 549.100 series
Horizontal pulling at bottom of picture.

A condition of horizontal pulling on the bottom half of the picture may be caused by a leaky 3.3- μ f capacitor located from grid to cathode in the second-video intermediate-frequency stage. It is a very elusive condition in that it may require one to two hours operation of the set for the capacitor to heat sufficiently and it is also a direct function of signal strength.

Investigations disclosed that this condition probably will not exist in strong-signal areas. It was noted that a d-c leakage resistance of $1\frac{1}{2}$ to 10 megohms caused this trouble.

SEARS ROEBUCK

Chassis 549.100-5

Insufficient vertical scan or foldover.

If the above receiver does not have adequate vertical scan or if vertical foldover is present at the bottom which cannot be removed, it is likely that a higher-gain amplifier will be necessary. There is a newer type tube, the 6BL76T, which has a much greater mutual conductance, now available for this application. This tube will provide full scan if a hand-picked 6SN7 is still unsatisfactory.

SEARS ROEBUCK

Chassis 549.100-8, -9

Width-coil failures.

Reports have been received of excess failures of width coils. Examination and study of samples and chassis indicate that most of these failures occurred when excessive width was had and the slug was adjusted to reduce width. Under these conditions, the h-v filter capacitor was returned to ground. Later production of these sets had the 500- μ mf, 20,000-volt capacitor returned to pin 5, 6W4GT damper tube. This gives a slightly higher picture voltage and consequently narrower picture. When replacing a width coil, connect the 500- μ mf, 20,000-volt capacitor to pin 5 of the 6W4.

SEARS ROEBUCK

Chassis 549.101 series

Horizontal instability.

For multiple pictures on these chassis, carefully check C148A, 10,000- μ mf capacitor connected between terminals C and D on the hori-

zontal-oscillator transformer. This capacitor largely determines the horizontal-oscillator frequency. Replace only with a molded-type capacitor.

SEARS ROEBUCK Chassis 549.102

Installation of replacement width coil.

Some replacement width coils for the above chassis have two individual windings, two connections of which must be joined for a tapped third connection. The inner winding may be connected to two terminals at the rear of the coil while the leads of the outer winding may be connected to two terminals at the rear of the coil and the leads of the outer winding may be hanging loose.

When wiring this unit into the receiver, the two terminals are to be connected to terminals 5 and 6 of the horizontal-output transformer. One of the leads from the outer coil is also connected to the terminal on the coil that goes to pin 5 of the transformer. The other lead is then connected to the horizontal-oscillator circuit for the afc control. Since leads on the width coil are not connected, it is possible to wire the outer winding in reverse so that the two windings are bucking each other instead of aiding.

To check for proper coil installation, an oscilloscope should be connected between pins 5 and 6 of the horizontal-output transformer and the amplitude of the wave on the scope checked. The scope should then be connected between the lead of the width coil that goes to the oscillator circuit and pin 6 of the horizontal-output transformer, and the waveform amplitude noted. If the scope

indicates that the amplitude of the wave increases, proper wiring of the width coil is assured. In the event the waveform decreases as the scope connection is changed, it will be necessary to reverse the lead connections of the outer-coil windings.

SEARS ROEBUCK

Chassis 549.102 series

Bending or curling at top of picture.

If a condition exists wherein a tendency of vertically-positioned lines to bend toward the right, especially at the top of the picture, this condition can occasionally be corrected by replacing the horizontal-oscillator tube, *V110*, a 12SN7GT, with another tube. However, if changing this tube does not produce the desired result, then add a 4,700- μmf capacitor across *C144*, a 1,000- μmf capacitor. This capacitor is located in the plate circuit of *V110* (horizontal-oscillator control tube) and is attached from pin 5 to ground. If the 4,700- μmf capacitor is not available, remove the 1,000- μmf unit and substitute a 5,600- μmf capacitor. It will probably be necessary to readjust the horizontal-frequency transformer *T106*. This change, while correcting the bending of the picture, may in some instances make the horizontal circuit less immune to noise impulses.

SEARS ROEBUCK Chassis 549.102

Vertical rolling in strong-signal areas.

If a strong signal causes vertical rolling of the picture, replace *R117*, an 82-k resistor in the grid circuit of *V101* (first-video i-f tube) with an i-f grid choke part No. 53C219 available from the manufacturer.

If the picture still rolls change resistor *R141* on pin 2 of *V104* (sync separator) to 470 k.

SEARS ROEBUCK Chassis 549.102

Vertical collapse of raster.

If vertical collapse of the raster occurs, change the vertical-oscillator tube first and then change the values in the sync separator and vertical-oscillator circuits as follows:

1. Interchange *R139* (8,200 ohms) and *R140* (3,300 ohms). Both resistors are tied to terminal 3 of the vertical-integrating network.

2. Change *R147* from 330 k to 220 k. This resistor is connected between the grid of the vertical oscillator and the junction of *C129* and *C133* (both 1,000- μmf , 800-volt capacitors).

3. Change *C134* from .02 to .05 μf . This capacitor couples together the two sections of the vertical oscillator and output tube.

4. Change *C133* from 1,000 μmf to .005 μf . This capacitor is in the feedback network from the output section to the input section of the vertical oscillator and output tube.

5. Add in series between *R147* and the junction of *C133* and *C129* a .005- μf capacitor.

6. Shunt *C129* with a 100-k resistor.

SEARS ROEBUCK Chassis 549.102

Insufficient picture height.

If there is insufficient picture height and the vertical oscillator is a 12SN7, *R170* (B-supply dropping resistor) should be 1,000 ohms, 2 watts instead of 4,700 ohms, 5 watts. Also remove the soldered wires from terminal 4 on the horizontal-output

transformer and resolder to pin 7 of the damper tube. Remove *C162* and *R171* between pin 7 and pin 3 of the damper tube and replace with jumper wire. (Note: Do not make these changes if vertical oscillator is a 12BH7.)

SEARS ROEBUCK Chassis 549.102
Audio-hum reduction
 (see Fig. 39).

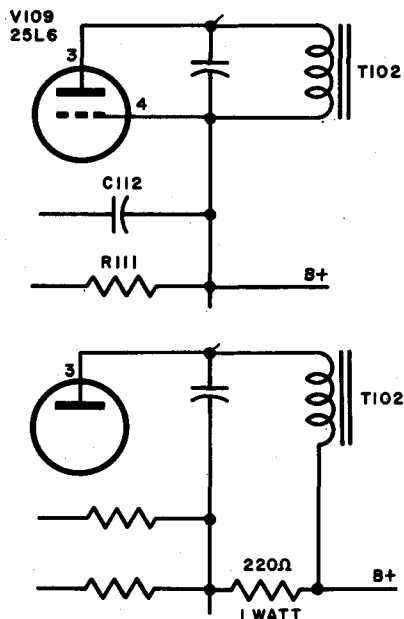

Fig. 39 — Sears Roebuck

In the above chassis, audio hum can be slightly reduced by adding a 220-ohm, 1-watt resistor as shown in the figure.

1. Open B+ (250 volts) at junction of *C112*, *R111*, *T102*, *R109*, and *R106*.
2. Insert a 220-ohm, 1-watt resistor.
3. Open the lower end of transformer *T102* lead from pin 4, 25L6.

4. Connect to B+ side of new 220-ohm resistor.

SEARS ROEBUCK

1950 549-series chassis
Picture intensity fluctuations with sound.

If loud passages of sound make the picture fluctuate in intensity, this indicates an improper regulation of the B+ supply to the intermediate-frequency and radio-frequency stages caused by insufficient filter capacitance. In some chassis, this capacitor is *C142*, a 50- μ f, 300-volt electrolytic.

A minimum of 50- μ f is required for this circuit. Therefore to correct this condition it will be necessary to shunt *C142* with a 20- or 30- μ f capacitor.

SEARS ROEBUCK

1950 549-series chassis
Arcing and burning.

An investigation of reports from the field on the above television sets burning out has indicated that there are two possible causes for this type of failure. The most frequent cause is arcing in the high-voltage box and the second most frequent cause is a short in one or two capacitors in the low-voltage B supply. The burnouts caused by high-voltage arcing increase with the coming of warm weather and high humidity, especially in areas close to the coast and in the southern part of the country. Burnouts due to the other cause are greater in the same areas but are also numerous in more temperate climates.

It is urged that every one of the above sets which comes to your shop for service for any reason have the following changes incorporated in it

to avoid the possibility of further trouble from these causes:

1. High-voltage arcing. The manufacturer will supply two parts to minimize the possibility of arcing. One is a polyethylene sheet, part No. 8-1042, which is placed around the inside of the high-voltage box between the 1X2 and the case. The second is a polyethylene plate-cap lead, part No. 76A613, which is to be soldered in place of the present exposed plate cap to the 1X2 high-voltage rectifier. If these two parts are installed and the dressing of the high-voltage leads carefully rearranged (if necessary), the possibility of damaging arcing is reduced.

2. The ground return for each of two capacitors should be changed to reduce the voltage impressed across them. A .035- μ f, 600-volt capacitor, C167, is connected between the horizontal-linearity coil and ground on most sets. The connection to ground should be lifted and attached to the 350-volt B+ lead which is the next terminal on the terminal strip. An 8- μ f electrolytic, C181, is returned to ground on some sets. This capacitor is connected to one side of the 10,000-ohm, 1-watt resistor tied to the cathode of the damper tube. If this is true, the ground return should be lifted and connected to the 115-volt, B+ line at the most convenient point. By making these changes where necessary, the impressed voltage is such that capacitor burnouts are reduced appreciably.

SEARS ROEBUCK Model 1141-20
Cemented ion traps.

After the above chassis has been correctly adjusted at the factory, the ion-trap magnet and sometimes the

focus coil are cemented to the neck of the picture tube to prevent movement, especially in transit.

When it is necessary to remove the tube, the Glyptol can usually be broken loose. However, if an excessive amount of cement is used, or the ion trap does not come off easily, do not apply pressure since the neck of the tube is the most fragile part of the picture tube and can break easily.

This Glyptol cement can be loosened easily with a solvent such as thinner and then removed without danger.

SEARS ROEBUCK Model 1141-20
Audio buzz.

Some 20-inch picture tubes in the above television sets do not have any aquadag outer coating. All of these sets should have a tube shield on the 6SQ7 tube, the first audio amplifier. If the receiver does not have this tube shield, a very strong vertical buzz will be picked up in the audio system. To correct that difficulty in the field, an ordinary snug fitting tube shield should be placed over the tube and a lug from the shield should be wrapped around pin 1 of the ground for the circuit.

SEARS ROEBUCK All chassis with
focus magnet
Focus-magnet adjustment.

In many models, a focus magnet (focalizer) is being used instead of a focus coil. The focusing adjustment in receivers where a focus magnet is used is comprised of one or two large screws mounted in the assembly itself. Either or both screws may be used as the adjustment. Two screws are used in order to provide maximum control range.

It will be noted that if these screws are adjusted with a steel screwdriver, the adjustment will change slightly when the screwdriver is removed. Ideally, a brass screwdriver should be used, but if this type of screwdriver is not available, care should be taken to check the adjustment after removing the screwdriver from contact with the adjustment screw.

Any adjustment of the focalizer should be made with the focus-adjustment screw turned clockwise until a gap of about 1/16 inch exists between the end of the screw and the front plate. To adjust the focalizer, loosen the clamping nuts until there is freedom of axial movement in all directions. With the ion trap properly adjusted, rotate the focalizer for optimum centering and absence of side shadows. Tighten the clamping nuts after proper adjustment has been made. The final adjustment for best picture focus should be made with the focus-adjustment screw.

The ion trap, focalizer, and focus-adjustment screw have some effect on centering, focus, brightness, and side shadows so that simultaneous readjustment is necessary. When the focalizer is positioned correctly, the other two will be relatively simple. The raster lines should be in sharp detail when these adjustments are properly completed.

SEARS ROEBUCK All chassis with focus magnet

Focalizer adjustment.

In several chassis a focus magnet (focalizer) is used in place of the focus coil. To most servicemen, a focalizer is apparently more diffi-

cult to focus correctly. However, there is a method adjusting the focalizer which will eliminate the time-consuming process of trial and error.

Adjust the drive control until the white line just disappears. Then set the focalizer and ion trap for the brightest picture without shadows. With the brightness control fully clockwise, turn the screws of the focalizer all the way in, then back out one turn. The focus may be correct at this point if the brightness control is returned to a normal level. If the focus is not in sharp detail proceed as follows:

Adjust the screws with a nonmagnetic screwdriver until the center of the picture is in sharp focus while the brightness control is turned fully clockwise. Then when the brightness is decreased to normal, the picture will be in focus across the face of the tube.

SEARS ROEBUCK

All chassis with electrostatic-focus picture tubes

Ion-trap magnet adjustment.

The position of the ion-trap magnet is very important with the low-voltage electrostatic focusing tubes such as 17HP4, 17MP4, 21HP4, 21MP4, etc. Misadjustment of the ion-trap magnet may cause imperfect centering of the picture-tube electron beam and result in excessive bombardment of the masking aperture within the electron gun. As a result of such bombardment, ions may be formed beyond the control of the ion trap and produce an ion spot on the fluorescent screen. Picture tubes utilizing low-voltage elec-

trostatic focus are more susceptible to this type of damage than tubes using magnetic focus, possibly because the converging effect of an electrostatic focusing field on the ions is greater than that of a magnetic focusing field.

Recommended Procedure:

1. Center the deflecting yoke on the tube neck and press the mounting-bracket cushion firmly against the glass funnel.

2. Place the ion-trap magnet on the tube neck. The proper initial position of the ion-trap magnet is in line with or slightly below grid 2, or about $\frac{3}{4}$ inch from the tube base. The south pole of the magnet should be adjacent to pin 2, and the north pole should be adjacent to vacant pin position 8.

3. Adjust the brightness or background control of the television receiver midway between its minimum and maximum positions and set the picture or contrast control to its minimum position. The brightness-control adjustment will provide the picture tube with grid-1 voltage approximately midway between zero and cut-off; the picture control adjustment will provide a blank raster on the picture-tube screen for observation during subsequent adjustments. With some receivers incorporating automatic gain control it may be necessary to disable the agc circuit temporarily so that a blank raster will be obtained on the screen.

4. With the controls set as indicated in above, apply operating voltages to the tube. As soon as the tube cathode reaches operating temperature, adjust the position of the ion-trap magnet by moving it a short

distance forward or backward and rotating it slightly until maximum brightness is obtained at the center of the raster. It is important that this adjustment be made with the brightness control set midway between the minimum and maximum positions to keep the beam current low. It is equally important that the adjustment of the ion-trap magnet be completed quickly, because operation of the picture tube with the ion-trap magnet improperly positioned may damage the tube. With certain electrostatic-focus picture tubes, two positions of the ion-trap magnet may be found in which maximum brightness is produced. The correct position is that which is nearer the base of the tube.

5. Focus the pattern and center it. These operations depend on the type of focusing and centering devices employed. If a shadow appears at the edge of the raster, check the position of the deflecting yoke to make sure it bears firmly against the glass funnel and is centered on the picture-tube neck. If any shadow remains, eliminate it by adjusting the position of the centering magnet. If this adjustment reduces maximum brightness at the center of the screen or disturbs centering and focus, repeat steps 4 and 5. Never adjust the ion-trap magnet to center the pattern; never adjust it to eliminate neck shadow if such adjustment reduces the brightness at the center of the screen.

6. With the picture control in its minimum position, turn the brightness control to its maximum setting and readjust the ion-trap magnet as indicated in step 4 until maximum light output at the center of the

raster is again obtained. Bowing of opposite sides of the raster in the same direction may occur if the ion-trap magnet has improper rotational position.

7. Adjust the brightness and picture controls to obtain a picture of normal brightness. Readjust centering and focus if necessary. If this step requires any appreciable change in centering or focus, repeat step 6 to recheck position of the ion-trap magnet.

SEARS ROEBUCK All chassis with GI tuners

Dial-cord slippage.

If the dial cord becomes loosened on the GI television tuner and causes slippage of the fine-tuning control, carefully reset the cord to the original position by observing the place where the cord had been cemented. Apply Glyptol cement generously to this spot and allow sufficient time for drying before rotating the fine-tuning shaft.

SEARS ROEBUCK All chassis with 1X2

Substitute 1X2 socket connections (see Fig. 40).

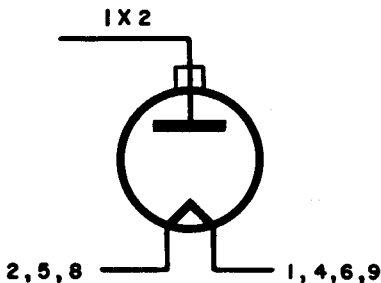

Fig. 40 — Sears Roebuck

The socket connections of the 1X2 are very fragile and can break easily. However, it is not necessary to replace the tube socket when this happens. Pins 1, 4, 6, and 9 are connected together to one side of the filament while pins 2, 5, and 8 are connected to the other side of filament. If one of the socket connections breaks, resolder the leads to one of the other pins in the series.

SEARS ROEBUCK All chassis with built-in antenna
Tweet modulation on channel 5 or 7.

Whenever any built-in antenna is incorporated in a television set and an external antenna is used for any reason, the leads from the built-in antenna should be carefully positioned away from the antenna terminals or lead-in wires from the antenna terminals to the tuner. In some cases, direct contact of the built-in antenna with the antenna terminal strip may cause a condition of "tweet modulation" on channel 5 if a 21-mc i-f system is used, or channel 7 if a 41-mc i-f system is used. This is evidenced by a shifting r-f diagonal pattern visible on the face of the picture tube. This pattern will be very tunable and will usually be shifting constantly.

SEARS ROEBUCK All chassis with 75-ohm input
Antenna-matching section (see Fig. 41).

The purpose of this arrangement (shown in the figure) is to connect a 300-ohm lead-in to those sets employing a 75-ohm antenna input. It consists of two adapters, one 14

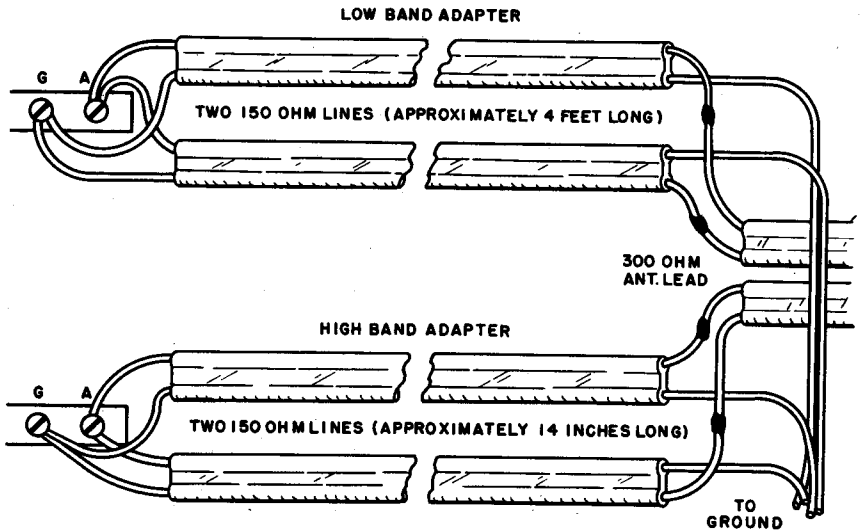

Fig. 41 — Sears Roebuck

inches, and one 4 feet long, each consisting of two 150-ohm leads, connected in parallel at one end and in series at the other end so that d-c continuity exists across the paralleled connection.

Connect the high-frequency antenna lead across the series end of the 14-inch adapter. Connect the parallel leads to the 75-ohm input for the high band, connect the center lead (one from each pair) to ground. In the same manner connect the 4-foot adapter between the low-band leads.

SEARS ROEBUCK All chassis in console cabinets
Warped doors on consoles.

In many cases, mild warpage of the doors on consoles can be corrected or minimized by the following methods:

1. Installation of bullet catches, preferably with stop, at the bottom of the doors. This method is par-

ticularly effective on panel-type doors.

2. Rehangng of doors. Sometimes improperly hung doors accentuate the appearance of being warped. Merely relocated hinges will compensate for slight warpage.

3. Gluing of a felt pad on one side of the wood-stopper block at the top of the cabinet. By this method a door which is slightly depressed may be brought forward.

4. Combine two or all of the above methods given.

SEARS ROEBUCK All chassis
Connecting unmatched coax to receiver.

Where receivers have dual inputs, that is for 75 and 300 ohms, it has been found that by connecting the coaxial cable unmatched across the 300-ohm terminals of the receiver, an increase in the signal is noted. However, it must also be

noted that when you do this, you make the coaxial cable subject to noise pick-up and lose a large quantity of the noise-reduction factor of coaxial cable.

Also, it has been found that in using certain antennas the elimination of the line-balance converter (made of 60 inches of coax) slightly increases the amount of signal to the receiver but also there is a greater noise pick-up.

Connecting the receiver unmatched or the antenna unmatched should, therefore, not be done in the face of high-noise signals such as one would get from automobile ignition, interference, etc.

SEARS ROEBUCK All chassis
Hum and buzz.

To reduce residual hum and buzz after the sound system has been properly aligned and all previously recommended changes made, the following suggestion should be used.

Add a capacitor of 100 to 500 $\mu\mu\text{f}$ from the grid of the first audio-frequency amplifier tube to ground. Also, the leads and parts in the ratio detector and audio circuit should be dressed very carefully.

The source of hum and buzz is probably radiation from the synchronizing and vertical circuits and 15.75 kilocycles radio frequency from the horizontal-output circuit.

SEARS ROEBUCK All chassis
Ion trap positioning.

Several chassis have the ion trap cemented to the neck of the tube to prevent movement in shipment. However, since the ion trap positioning is dependent on both deflection yoke and focus coil, movement of

either will require a correction of the ion-trap location.

When a serviceman feels the ion-trap magnet is incorrectly positioned, he will usually break the seal and reset the trap. In many cases the magnet was correctly placed and the effect of the sealing is lost. It is not necessary to break the seal to check the magnet. If another magnet of any type, even a small bar magnet, is placed at various positions about the trap and round the neck of the tube with no increase in brightness, the ion trap is correctly positioned. However, should the picture increase in brightness, this would indicate a misplaced ion trap that should be worked loose and reset.

SEARS ROEBUCK All chassis
Reduction of intercarrier buzz.

If a prominent humming or buzzing sound is noted in the sound reception of a television broadcast, it may be due to a fault in transmission from the station, or incorrect adjustment of the discriminator transformer (tuning of secondary circuit) in the receiver.

This type of disturbance, which is only present when receiving a station signal, is known as "intercarrier buzz" and it should not be confused with power-supply hum that would occur upon failure of a filter capacitor.

The procedure for correct adjustment of the television sound-discriminator circuit is presented in the service notes. When the discriminator secondary slug is properly adjusted, intercarrier buzz will be reduced to an acceptable minimum, provided

that the transmission from the station is not at fault.

SEARS ROEBUCK All chassis
Arcing and corona.

Arcing or corona may be due to poorly soldered connections (rosin joints or sharp points), or defective tube-socket connections. If the leads or connectors to the high-voltage filter capacitor do not grasp this component securely, arcing will result. Inspect solder connections and resolder those joints which are unsatisfactory. Make sure tubes are firmly positioned in tube sockets and that high-voltage filter capacitor is held securely in place.

Arcing or corona may occur when h-v components or leads are placed too close together. Make sure there is sufficient spacing between all parts and wiring. If necessary, the insulation between two elements of the circuit may be improved by coating both objects with a quick-drying liquid polystyrene or polyethylene.

The socket assembly for the 1B3GT/8016 rectifier tube includes a corona ring which prevents corona from the tube socket connections. The surface of this ring should be smooth and free of scratches, nicks, or sharp protrusions. A plastic spray known as Krylon is now available in a bomb-type dispenser. This plastic material has a high insulation content which makes it of particular value in coating high-voltage transformers and sharp points of contact in the high-voltage circuit. As a further protection, the inside top cover and walls of the high-voltage compartment may be sprayed with this plastic to prevent corona.

The material will also protect the high-voltage transformer against high humidity breakdowns if it is sprayed after heating in a dry condition. However, the transformers must be dry before coating or the seal may only cause a more rapid internal breakdown.

This spray dries in one to two minutes and can be used in a customer's home.

SEARS ROEBUCK All chassis
Antenna-matching sections for high-noise area (see Fig. 42).

Television antenna installations in locations having high electrical noise levels require 72-ohm coaxial

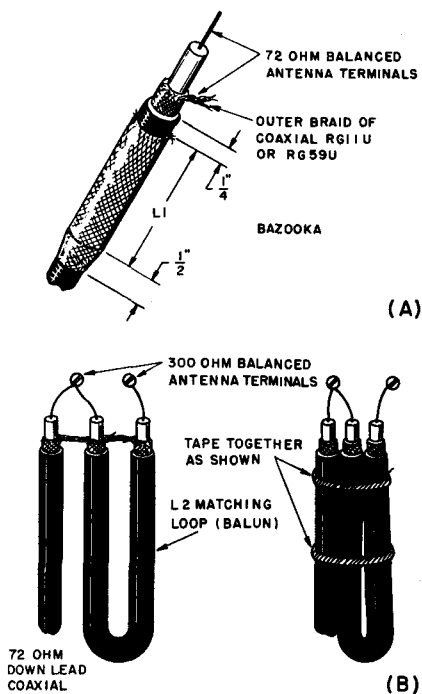

Fig. 42 — Sears Roebuck

cable lead-in to reduce noise pick-up in the down lead. All dipole-type antennas are balanced devices, while coaxial cable is unbalanced. The television set input is usually 300-ohm balanced.

A 300-ohm television antenna connected by 300-ohm twin lead to a 300-ohm set input requires no special matching but almost all other combinations of antennas and lead-ins do.

To provide a balanced connection from 72-ohm coaxial cable to a 72-ohm antenna (straight dipole and many Yagi types), a transformer, commonly called a "bazooka," is required. This matching device is easy to make, as shown in part (A) of the figure.

1. For Yagi antennas cut to a specific channel, refer to following list to determine the length of the bazooka to match the desired channel.

2. Cut the specified length ($L1$) of copper braid or shielding just large enough in diameter to fit over the 72-ohm coaxial cable.

3. At the specified distance from the end of the cable $L1$ (from where the shielding ends) strip off about $\frac{1}{2}$ inch of the outer insulation of the coax and bond one end of the copper braid to the coaxial-cable braid. Make a secure connection, but be careful with a soldering iron as the plastic center insulation is easily destroyed. Usually a tightly wrapped connection of the braid will suffice if polyethylene tape is used for sealing.

4. Connect the center conductor of the coax to one antenna element and the sheath of the coaxial cable

to the other antenna element. No connection is made to the end of the outer copper braid. It is connected only at the specified point to the coaxial cable sheathing.

To connect 72-ohm coaxial cable to any balanced 300-ohm device (most conical, folded dipole, and other antennas as well as 300-ohm receiver inputs), use a matching loop or Balun. This loop is easy to make on the job as shown in part (B) of the figure.

1. Refer to the chart for specified length of loop if matching to a 300-ohm Yagi antenna for a certain channel. For the best all-channel compromise in matching to any broad band antenna or to the receiver input, use a 60-inch loop. Measure the loop length from ends of sheathing — not to the ends of the exposed center conductor. For example, cut 64 inches of cable to make a 60-inch loop to leave 2 inches of exposed center conductor at each end.

2. Strip outer insulation and braid for 2 inches from ends of the loop and downlead cable. Nest three ends together so braids of all three can be connected by wrapping tightly with wire or narrow braid.

3. Connect center conductors of downlead and one end of loop together. This is one 300-ohm terminal. The other 300-ohm terminal is the other end of the loop center conductor.

4. For neatness and security, dress the loop against the downlead and tape at intervals, being careful to avoid too sharp a bend in the loop.

As with all coaxial cable outdoor work, seal the exposed cable ends with Krylon or other suitable in-

sulating weatherproof compound to prevent entry of moisture into cable.

Chart of Matching Lengths by Channels

Channel	72 To 72		72 To 300	
	Bazooks L1	Ohm	Balun L2	Ohm
2	34½ "		68½ "	
3	31¼ "		61⅞ "	
4	28½ "		56½ "	
5	25 "		49⅜ "	
6	23 "		45⅞ "	
7	11¼ "		22 "	
8	10¾ "		21¼ "	
9	10½ "		20⅝ "	
10	10 "		20 "	
11	9¾ "		19⅜ "	
12	9½ "		18⅞ "	
13	9¼ "		18¼ "	
Broadband	29 "		60 "	

SEARS ROEBUCK All chassis
Elimination of interference from f-m receivers.

All frequency-modulation receivers radiate a signal produced by the local oscillator. The intensity of this radio-frequency signal varies widely with different types of receivers and depends to a large extent on the type of f-m antenna being used.

In fringe areas for television reception, it is often possible for an f-m receiver to produce an interference pattern of closely spaced light and dark vertical and/or diagonal bars across the picture. Where the television signal is very weak and the radio-frequency radiation is strong, the television picture may be blanked out entirely.

Each case of f-m receiver interference requires some analysis to determine the most effective correction. First, determine the f-m television

station frequencies involved. If the offending f-m receiver is usually tuned to a particular f-m transmitter, the problem is somewhat simpler.

Broadcast f-m transmissions are between 88 and 108 mc. The f-m receiver intermediate frequency is around 10 mc (10.7 for most). This means that the f-m receiver oscillator ranges between 77.3 mc and 97.3 mc (if it operates below signal frequency), or 98.7 and 118.7 mc (if it operates above signal frequency).

Most f-m receivers have the oscillator frequency lower than the station. If this is the case, its radiation will fall in either channel 5 (76 — 82 mc) or channel 6 (82 — 88 mc).

Second-harmonic radiation will fall on channel 7 through 10, or if the f-m local oscillator is tuned above the station, no fundamental radiation will fall on any television channel, but second-harmonic radiation will fall on channel 10 through 13. Second-harmonic radiation is usually not very severe and can be minimized much easier than fundamental radiation.

Since most fringe areas for television are also fringe for frequency modulation, an outdoor f-m antenna is usually in use. The usual design for these antennas is such that they will radiate in all directions, which aggravates the problem. If f-m reception is only from one direction, an f-m dipole with a reflector may be used, limiting reception to one direction.

Disconnect the f-m receiver antenna from the set and observe whether the radiation is reduced. If it is eliminated or reduced to a satisfactory level, then a trap in the antenna

lead at the set will probably cure the difficulty. The trap to use is a sharply tunable type which covers the computed oscillator frequency. Such traps are available through local radio-supply houses.

If the radiated signal is not reduced sufficiently by disconnecting the f-m antenna, it may be assumed that the oscillator is radiating directly from the tube, coil, or associated circuits. Try a well grounded tube shield which covers the oscillator tube thoroughly. If other methods fail, then a complete shield made of metal screening should be tried, covering the entire chassis. Usually grounding to the chassis at one point only is more effective than several grounds.

In some special cases where the interfering oscillator frequency and the television channel affected are in the proper relationship, it may be possible to eliminate the interference by shifting the intermediate frequency a few tenths of a megacycle. Be careful not to shift f-m intermediate frequency too much, as this will produce poor tracking and lower sensitivity.

Do not confuse "tweet modulation," which appears as tunable moving light and dark bars on channel 5 of television sets using 25.75 mc intermediate frequency, with local f-m receiver interference. "Tweet modulation" results from feedback from the i-f amplifiers or video detector into the tuner input. The third harmonic of the 25.75-mc picture intermediate frequency is 77.25 mc (channel 5).



SENTINEL

Models 400, -1,
-2, -5, -6, -11

Tearing when set is jarred
(see Fig. 43).

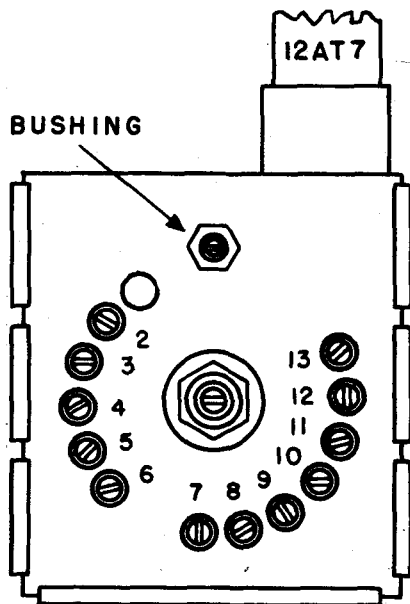

Fig. 43 — Sentinel

Tearing and picture break-up (noise streaks) when set is jarred may occur in the above models which use a 12AT7 oscillator tube. This is due to a loose fit between padder-trimmer screw and threaded sleeve, preventing a firm grounding contact.

The installation of a locknut bushing, part No. PST 500, on the padder-trimmer screw, will hold the trimmer screw firmly and provide a proper ground. Slide the locknut bushing on a thin-bladed screwdriver with the nut end toward the handle and insert the screwdriver into the trimmer-screw slot. While holding

the padder-trimmer screw so that it will not turn, slide the locknut bushing on the padder trimmer and turn it down by hand until it is tight against the front of the r-f tuner unit chassis. Do not turn the locknut down too tight, as this might result in stripping the screw or damage to trimmer. Then, solder the nut to the tuner frame. Finally, check each local-channel oscillator trimmer for correct adjustment.

SENTINEL Models 401, -2, -6,
-7, -9, 411 through
416, 419 through
425, 428

Critical horizontal hold.

Critical horizontal-hold control action and/or inability to adjust horizontal hold, have in some cases been traced to a leaky .05 μ f, 600-volt feedback coupling capacitor between one side of the width coil and the phase detector. This may cause several resistors to change value. These resistors are the 4,700-ohm resistor (3,300-ohm resistor in a few models, 10,000-ohm resistor in a few other models) used in series with the .05- μ f, 600-volt feedback capacitor, the 27,000-ohm resistor used in the cathode of the 6AL5 phase detector, and the 5,600-ohm resistor used in the plate circuit of the horizontal-oscillator tube.

High-resistance leakage in the feedback capacitor will place B+ on the 4,700-ohm and the 27,000-ohm resistors causing them to change value. The phase-detector circuit then places a greater amount of positive bias on the grid of the horizontal-oscillator tube resulting in increased current through the 5,600-ohm plate resistor which changes its value.

A shorted .05- μ f, 600-volt feedback capacitor will result in no high voltage. Therefore, no raster will appear on the picture tube. A simple check to determine whether the capacitor is shorted is to remove the 6AL5 tube while the set is in operation. If the raster appears with the tube removed, the feedback capacitor is shorted. When replacing a shorted feedback capacitor, always check the 4,700-ohm, 27,000-ohm, and 5,600-ohm resistors for proper value.

SENTINEL Models 401, -2,
-6, -11, -62J

Premature failure of audio-output tube.

Premature failure of the 6AR5 audio-output tube may occur due to envelope breakage. The tube shield used over the 6AR5 tube fits very snugly and if there are any minute flaws in the glass envelope, the envelope will break because of expansion caused by the heat of the tube.

When replacing 6AR5 tubes, do not reinstall the tube shield. This was used solely to prevent the tube from dropping out of its tube socket during shipment.

SENTINEL Models 402CV,
406CV, 411CV

Eliminating circular corner shadow on replaced picture tube.

After installing new picture tube, make adjustments as given in the service notes. If shadow still remains, proceed as in the following paragraphs.

1. Reverse the green and yellow leads coming from the focus coil at their connecting points on the tie

lug underneath and in the center of picture chassis.

2. Repeat procedure as outlined in the service notes.

SENTINEL Models 412, -13, -14, -15

Improving horizontal hold
(see Fig. 44).

Field reports indicate that with some types of tubes there was a

tendency for the above models to require a different setting of the horizontal-hold control when the set was first turned on (cold) and after it was warmed up (hot). To correct this, the following changes have been incorporated in chassis having Series YG ink-stamped on the back of the chassis. They are not included in chassis stamped Series YA, YB, YC, YD, YE and YF.

1. The .005- μ f capacitor *C55* and the 470,000-ohm resistor *R56*, parallel filter in the output circuit of the 6AL5 phase detector, are removed from the circuit.

2. The 100,000-ohm resistors *R55* and *R59* in the output circuit of the 6AL5 phase detector are replaced by a series-parallel resistor and capacitor combination consisting of the following:

a. The 100,000-ohm resistors *R55* and *R59* are changed to 470,000-ohm, 5%, 1/2-watt resistors, part No. 27E1009-25.

b. Two .002- μ f, 200-volt capacitors *C85* and *C86* are added in parallel with *R55* and *R59*. Part number of the capacitors is 23E205.

c. Two 33,000-ohm, 10%, 1/2-watt resistors *R116* and *R117* are added in series with *R59* and pin 5 and in series with *R55* and pin 7 on the 6AL5 phase-detector tube socket. Part number of these resistors are 27E333-2.

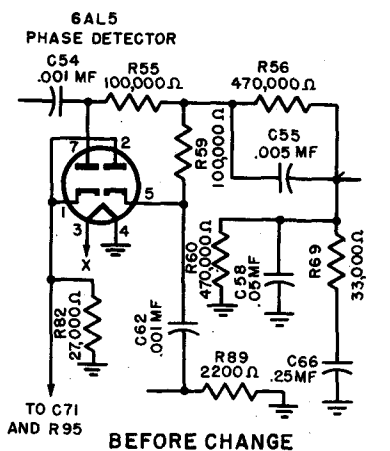

BEFORE CHANGE

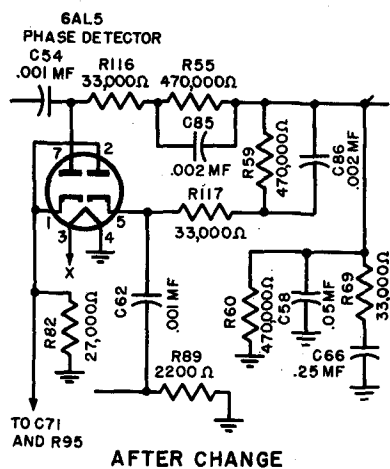

AFTER CHANGE

Fig. 44 — Sentinel

SENTINEL Models 412, -13, -15

Increasing audio output.

To increase audio output the following changes, already incorporated in the latter part of Series YD production, are made:

1. The 6,000-ohm, 140-volt line bleeder resistor $R106$ is changed to a 5,000-ohm, 5-watt resistor, part No. 27E1016-4.

2. The 180-ohm resistor $R36$, in the cathode circuit of the 6AU6 sound i-f amplifier tube, is changed to a 270-ohm, $\frac{1}{2}$ -watt resistor, part No. 27E271-2.

SENTINEL

Models 412,
-13, -15

Increasing range of horizontal-centering control.

To provide a greater range of the horizontal-centering control, the following changes, already incorporated in all chassis starting with the latter part of Series YD production, are made:

1. The 30-ohm horizontal-centering control $R103$ is changed to 60 ohms.

2. The 500- μ f capacitor $C82$ located across the centering control is changed to a 1,000- μ f, 5-volt capacitor, part No. 25E52.

3. The B+ take-off point for the audio section is moved to the variable tap on the horizontal-centering control.

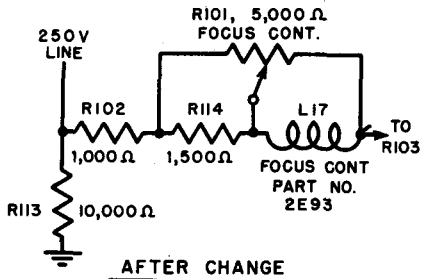
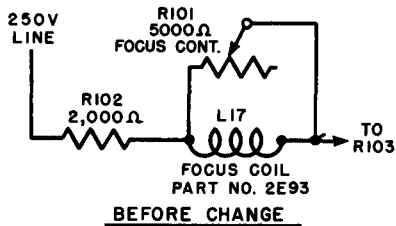

Fig. 45 — Sentinel

output side of the focus coil, $L17$. Part number of this resistor is 27E1016-11.

3. The focus control $R101$ is rewired so that it is across the focus coil $L17$ and the 1,500-ohm resistor $R114$ that has been added in series with the focus coil. The variable tap from the focus control is connected between the 1,500-ohm resistor and the focus coil.

4. A 10,000-ohm, 10-watt bleeder resistor $R113$ is added between the 250-volt line (output side of $R102$) and ground, part No. 27E1016-9.

SENTINEL

Models 412,
-13, -15

Increasing range of focus control (see Fig. 45).

To increase the range of the focus control, the following changes, already made in later production, are incorporated:

1. The 2,000-ohm series resistor $R102$ is changed to a 1,000-ohm, 7.5-watt resistor, part No. 27E1016-10.

2. A 1,500-ohm, 5-watt resistor $R114$ is added in series with the

SENTINEL

Models 412,
-13, -15

Eliminating retrace lines and making vertical hold less critical.

To eliminate retrace lines on top of picture and also to make the vertical-hold control less critical, the

following changes, incorporated in later production, are made:

1. The plate voltage on pin 2 of the 6SN7 vertical-oscillator tube is raised by connecting the 47,000-ohm resistor *R53* to the output side of *R98* (2,200 ohms) and *C81* (15 μ f).

2. The 47,000-ohm, 1-watt resistor *R53* in the plate circuit of the 6SN7 vertical-oscillator tube is changed to a 47,000-ohm, 2-watt resistor, part No. 27E473-5.

3. The 220,000-ohm, 1/2-watt resistor *R74*, in series with the vertical-hold control, is changed to a 100,000-ohm, 1/2-watt resistor, part No. 27E104-2.

SENTINEL Model 416
Improving horizontal stability
 (see Fig. 46).

The following circuit changes are made to improve the horizontal hold when P-1003 horizontal-output transformer is used. If receiver is marked Series YA on back of chassis, proceed with all the changes given below. If receiver is marked Series YB or YC, it is not necessary to perform the first four steps.

1. The 4.7-meg resistor *R59* (connected to the junction of the two 100,000-ohm resistors wired from pin 5 to 7 of the phase detector to ground) is removed from the circuit.

2. The .005- μ f capacitor *C49*, part of the parallel filter in the output circuit of the phase detector, is removed from the circuit.

3. The 470,000-ohm resistor *R52*, part of the parallel filter, is rewired

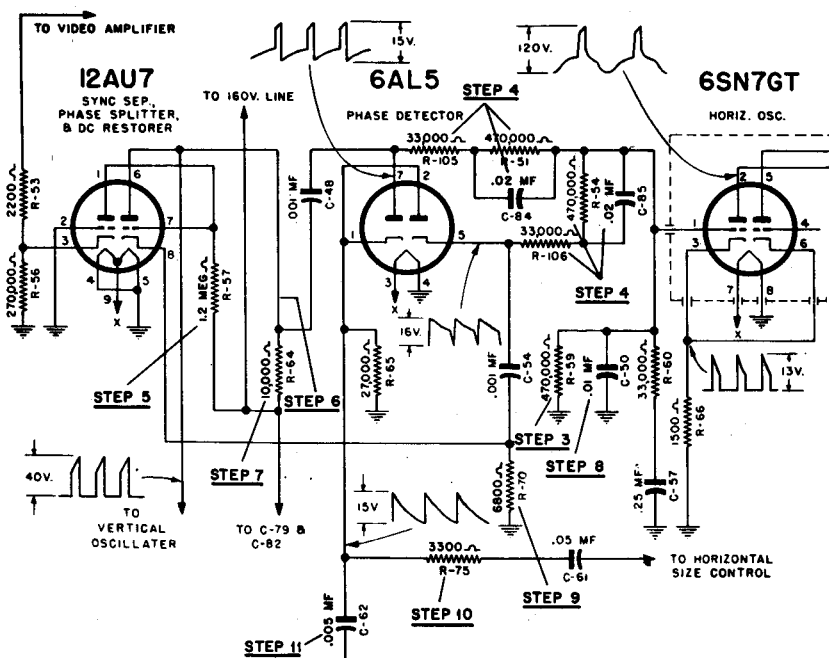

Fig. 46 — Sentinel

to ground to take the place of R59 removed in step 1 above.

4. The two 100,000-ohm resistors R51 and R54 in the output of the phase detector are replaced by a series-parallel resistor-capacitor combination made up as follows:

a. A 33,000-ohm, $\frac{1}{2}$ -watt resistor in series with a 470,000-ohm, $\frac{1}{2}$ -watt resistor.

b. The 470,000-ohm resistor is paralleled by a .02- μ f, 200-volt capacitor.

c. One series-parallel R-C combination is used in each leg of the phase detector.

5. Resistor R57, an 820,000-ohm resistor connected to pins 1 and 7 of the sync separator, is changed to 1.2 megohms.

6. Resistor R58, 4,700-ohm resistor connected to pin 6 of the sync separator, is removed from the circuit and a jumper is added from the junction of R64 and C48 to pin 6 of the sync separator.

7. Resistor R64, a 3,300-ohm, $\frac{1}{2}$ -watt resistor in plate circuit of the phase splitter, is replaced with a 10,000-ohm, $\frac{1}{2}$ -watt resistor.

8. Capacitor C50, a .05- μ f capacitor from the grid of the horizontal oscillator to ground, is replaced with a .01- μ f, 400-volt capacitor.

9. Resistor R70, a 2,200-ohm, $\frac{1}{2}$ -watt resistor connected to the cathode (pin 8) of the phase splitter, is changed to a 6,800-ohm, $\frac{1}{2}$ -watt resistor.

10. Resistor R75, a 10,000-ohm, $\frac{1}{2}$ -watt resistor connected to pins 1 and 2 of the phase detector, is changed to 3,300 ohms at $\frac{1}{2}$ watt.

11. Capacitor C62, a .003- μ f capacitor connected from pins 1 and 2 of

the phase detector to ground, is changed to .005 μ f, 200 volt.

SENTINEL Models 419, -20,
-23, -24, -25, -28

Distorted or weak sound.

Distorted and/or weak sound occurring after the set has been in operation approximately a week or ten days has been traced to drifting of the discriminator transformer. To remedy, adjust the discriminator-secondary trimmer screw located on top of the discriminator-coil shield can.

Adjust this screw for both minimum buzz and clearest sound. Make sure that this position is between the two maximum buzz peaks that will be noticed when the adjusting screw is turned to the right or left of the minimum buzz position.

In later models, discriminator transformers are receiving an additional impregnation and baking process to eliminate the possibility of discriminator drift.

SENTINEL Models 419, -20,
-23, -24, -25, -28

Steady or intermittent high-frequency squeal (see Fig. 47).

A steady or intermittent high-frequency squeal is caused by mechanical vibration of the horizontal-output transformer. The squeal can be eliminated or reduced by making one or all of the remedies shown in the figure on Page 100.

SENTINEL Models 420, -23,
-24, -25, -28, -32,
-38, -39, -40,
-41, -43, -44

Reduction of buzz.

If station buzz is excessive and is not due to contrast control being

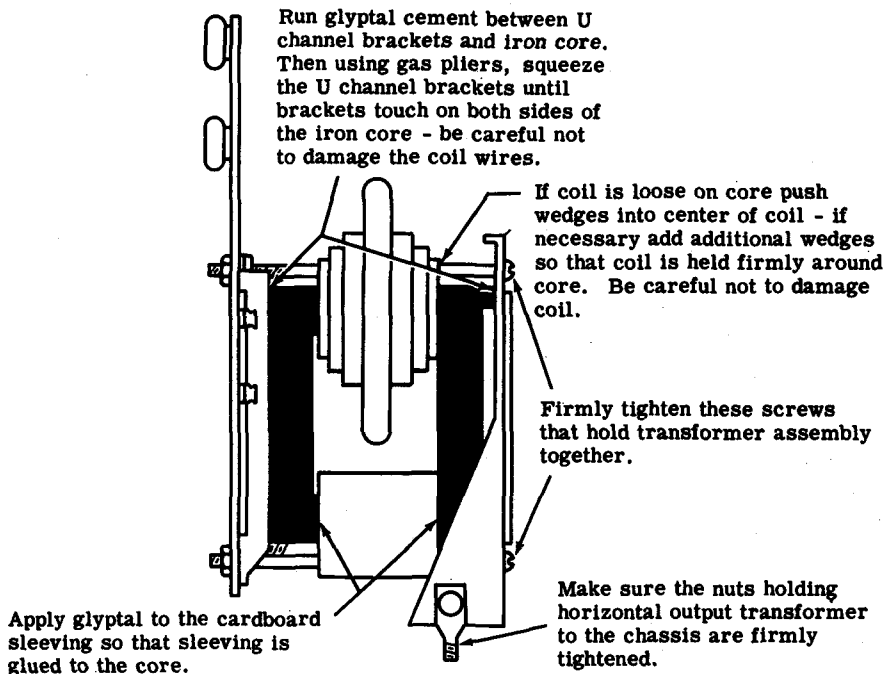

IMPORTANT

Make sure all horizontal output transformer leads are dressed away from this transformer, particularly the lead going to the fuse.

The self tapping screws holding the cage and cover around the horizontal transformer must be firmly tightened

Fig. 47 — Sentinel

too far advanced in clockwise direction, adjust the discriminator-secondary adjustment screw for minimum buzz. Make sure that this position is between the two maximum buzz peaks that will be noticed when the adjusting screw is turned to the right and left of the minimum buzz position. This screw is located on top of the discriminator-coil shield can which is mounted between 6T8 sound-detector tube and the 6AU i-f amplifier tube.

SENTINEL Models 420, -23, -24, -25, -28

Horizontal foldover at left.

Foldover may occur in the left side of the picture. This may show up as a faint milky-white area extending between the left edge and the center of the picture. The reason for the foldover is usually that the horizontal-hold control is out of adjustment; the extent of the area covered by foldover depends on the setting

of the control. To remedy proceed as follows:

1. Turn the horizontal-centering control until the left-hand edge of the picture becomes visible.

2. Adjust the horizontal-hold control to the point where the foldover just disappears. If the extreme top of the picture starts bending or jitter is noticed, then adjust horizontal-hold control for minimum foldover with acceptable stability. To find this setting it may be necessary to re-adjust the horizontal-lock control.

3. Center picture with horizontal-centering control. Do not at any time use the horizontal-hold control to center picture.

SENTINEL Models 420, -23,
-24

Eliminating corner shadow.

A semicircular shadow may occur around the corner of the pattern because the metal ring inside the focus magnet may have shifted position during shipment. To remedy proceed as follows:

1. Adjust the hex stud, located to the left of the focus-adjustment screw, with a circular motion until semicircular shadow is eliminated. Note: The hex stud should be adjusted with a brass, copper, or other non-magnetic tool.

2. Adjust the ion trap for maximum brightness. Note: Do not use ion trap to eliminate semicircular shadow around the corner of pattern, for by so doing the intensity of the raster is decreased.

If necessary, after completing the above procedures, recenter picture with the centering controls on the back of the chassis. Do not use the

horizontal-hold control to center the picture.

SENTINEL Model 420 **Replacement of picture tube** (see Fig. 48).

Because it may be difficult to obtain an exact field replacement of the type of 16-inch rectangular picture tube originally furnished with the receiver, the following procedure is developed to permit the use of any standard make of 16TP4 or 16RP4 picture tube for replacement purposes:

1. Completely install any standard make of 16TP4 or 16RP4 in place of the defective 16-inch rectangular picture tube.

2. Adjust horizontal-drive control for proper setting as described in the service notes.

3. If circular corner shadow is noted on picture tube, eliminate shadow by adjusting the four focus-coil assembly-mounting screws.

4. Adjust focus control for proper focusing.

Should it be found that when turning the focus control in the counterclockwise direction focusing is improved but is not proper even when the control reaches the maximum counterclockwise position, reduce the strength of the focus magnet as follows:

Place four steel strip shunts, approximately $\frac{3}{4}$ " \times $\frac{1}{8}$ " \times $\frac{1}{16}$ " around focus magnet as shown in part (A) of the figure. If this brings position of proper focusing within range of the focus control, no other changes are necessary. Should the addition of the four steel strip shunts improve focusing but still not bring correct focusing within the range of

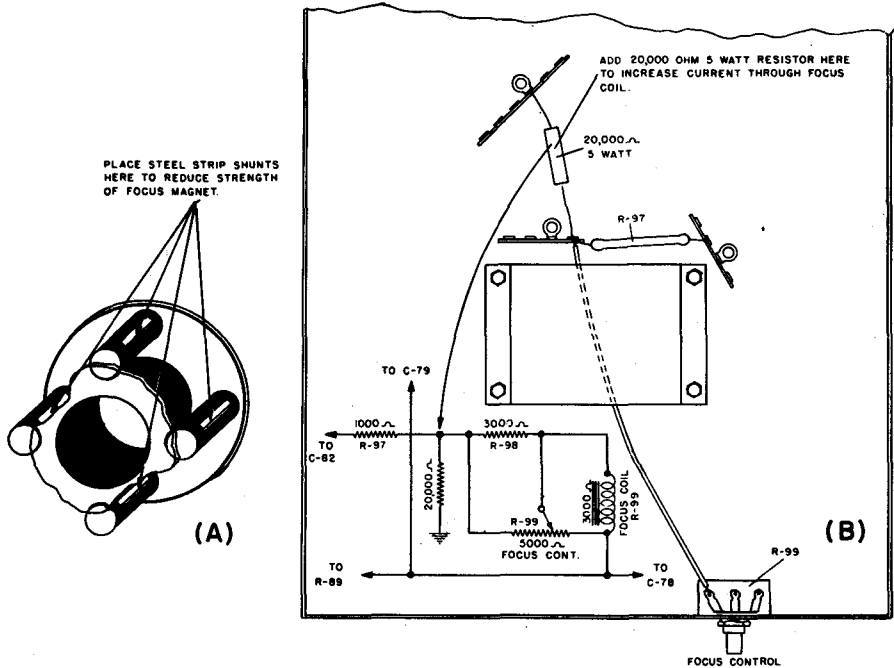

Fig. 48 — Sentinel

the focus control, add additional shunts until focusing position is within range of the focus control.

Should it be found necessary to turn the focus control in the clockwise direction and that focusing is improved but not proper even when the control reaches the maximum clockwise position, it will be necessary to increase current through the focus coil as follows:

Install a 20,000-ohm, 5-watt resistor, part No. 27E1016, as shown in part (B) of the figure.

SENTINEL Model 425 Eliminating corner shadow.

Semicircular corner shadow can be eliminated by the following procedure:

1. Loosen locking screw on the focus magnet just far enough to unlock the lever adjacent to this screw. This locking screw is located on the section of the focus-magnet assembly nearest the yoke and slightly to one side of the focus-adjustment control shaft.

2. Adjust this lever by either pushing up or pulling down and/or moving it from side to side until circular shadow is eliminated.

3. Lock lever in place by tightening locking screw.

4. Adjust ion trap for maximum brightness.

Note: Do not use the ion trap to eliminate semicircular shadow around corner of pattern, if by so doing the intensity of the raster is decreased.

If necessary, after completing the above procedures, recenter picture with the centering controls on the back of the chassis. Do not use the horizontal-hold control to center the picture.

SENTINEL Models 438, -39,
-40, -41, -43, -44,
-46, -47, -48
-49, -50, -51

Increasing range of tone control.

To increase the tone-control range so as to obtain greater variations in tone, proceed as follows:

1. Replace the 2,200-ohm resistor between the center and high (plate) side of the tone control with a jumper wire.

2. Replace the .047- μ f, 600-volt capacitor, located between the low side of the tone control and ground, with a .1- μ f, 600-volt capacitor.

SENTINEL Models 438, -39,
-40, -41, -43, -44

Increasing range of horizontal-drive padder.

To increase the range of the horizontal-driver padder, this control (C74, part No. 24E16-2, a 130-360- μ f capacitor is replaced with part No. 24E16, a 340-460 μ f capacitor. This change has already been made in chassis stamped "YA."

SENTINEL Models 438, -39,
-40, -41, -43, -44

Compensating for differences in ratio-detector coils.

To compensate for differences in the tertiary windings of ratio-detector coils, R41, a 270-ohm resistor, is used in some chassis in series with this winding. In other chassis,

a 68-ohm resistor is used. If or when the ratio-detector coil must be replaced, the 68-ohm resistor should be changed to 270 ohms.

SENTINEL Models 438, -39,
-40, -41, -43, -44

Preventing fuse failure under normal conditions.

To prevent the fuse used in the high-voltage supply from blowing under normal conditions, the 150-ma fuse (F2, part No. 40E8-7) should be changed to a 200-ma fuse.

SENTINEL Models 438, -39,
-40, -41, -43, -44

Preventing power transformer damage when rectifiers short.

To prevent damage to the power transformer should the low-voltage rectifier tubes short, the following change (already made in models stamped "YB") is incorporated:

Fuse (FI), part No. 40E8-6, a 1/2-amp Slo-blo fuse in the B-supply of the power transformer, is changed to a 2 1/2 amp Slo-blo fuse, part No. 40E8-9, which is connected in series with the primary of the power transformer.

Caution: These fuses are not interchangeable. Always use an exact replacement. The correct size fuse is clearly ink-stamped on the back of the chassis at the fuse holder.

SENTINEL Models 438, -39,
-40, -41, -43, -44

Minimizing failures of low-voltage rectifiers.

The two 6W4 low voltage rectifier tubes are changed to two 6BY5G tubes in models ink-stamped "YC."

In order to make this substitution, pins 4 and 5 are connected together on the tube sockets. In addition, pins 1, 2, and 8 are connected together on the socket of each tube.

SENTINEL Models 438, -39, -40, -41, -43, -44

Repeated failure of primary fuse.

The fuse used in the receiver power transformer primary circuit may blow repeatedly and yet checks show no apparent defects. There are two possible causes:

1. The No. 8 1-inch self-tapping back-mounting screw that holds the back to the chassis near the interlock plug touches one of the filament pins of either the 6W4 or 6BY5G rectifiers.

2. Receiver is equipped with a 2½-ampere Slo-blo fuse. This is replaced by a 3-ampere Slo-blo fuse.

To remedy proceed as follows:

1. Shorten length of back-mounting screw by placing ⅛-inch washer or washers under head of screw. Note: The back-mounting screw should always be in place to prevent any loose or intermittent connections at the interlock plug.

2. Install a 3-ampere Slo-blo fuse in place of the 2½-ampere Slo-blo fuse.

Note: A few chassis used a ½-ampere Slo-blo fuse in the secondary of the power transformer, therefore if the screw touches the rectifier socket in this type of chassis the ½-amp fuse would not blow. If the house fuse blows or the power transformer overheats, investigate the possibility of the screw shorting to the rectifier socket.

SENTINEL Models 447, -48, -49, -50

Popping sound when sets are turned on or off.

In 21-inch sets, popping sounds may be due to electrostatic-charge voltage built up between the picture tube and the built-in antenna. The lack of an outer dag coating on the picture tube creates this condition.

To remedy this condition, remove the built-in antenna. As the popping occurs only when the antenna is not connected to the set, it will cause trouble only when it is not needed.

In the 17-inch sets, popping sounds may be due to a similar electrostatic-charge voltage built up between the mask and the picture tube. To remedy, make a ground connection between the mask and the chassis.

SENTINEL Models 454, -55, -56, -57

Premature crystal-detector failure (see Fig. 49).

An early sign of crystal failure is excessive sound bars in the picture that are not due to fine-tuner mis-

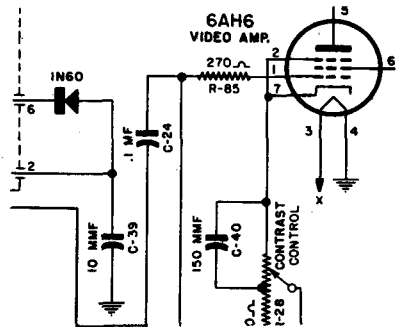

Fig. 49 — Sentinel

adjustment. Ultimately, complete failure will result in weak picture and loss of sync. This may be due to momentary surge current in the control-grid circuit of the 6AH6 video-amplifier tube due to internal shorting of the screen grid to the control grid. This will result in damaging the 1N60 crystal detector.

To remedy, add a 270-ohm, $\frac{1}{2}$ -watt resistor (*R85*) between the .1- μ f capacitor (*C24*) and the control grid (pin 1) of the 6AH6 video amplifier if this resistor is not already in the set.

SENTINEL Models 454, -55, -56, -57

Improving contrast range (see Fig. 50).

To improve the contrast range, two resistors are added to the B-boost line in order to lower the first-anode voltage of the picture tube:

1. In series with the B-boost line, add *R87*, a 220,00-ohm, $\frac{1}{2}$ -watt re-

sistor to the first anode of the picture tube (red lead).

2. Between the junction of the first anode of the picture tube and the resistor just added, and ground, add a *R88*, a 470,000-ohm, $\frac{1}{2}$ -watt resistor.

SENTINEL Models 454, -55, -56, -57

Increasing range of vertical-size control.

To permit greater variations of vertical size of the picture, add *R89*, a 2.2-meg, $\frac{1}{2}$ -watt resistor, between the open terminal of the vertical-size control and ground.

SENTINEL Models 454, -55, -56, -57

Picture rolling and tearing on strong signals (see Fig. 51).

Picture tearing and rolling may occur on strong signals. Be sure that this does not occur when the Locality Adjuster Switch is in the wrong position—on Weak or Medium position in a strong-signal location. This effect is produced by overloading of the 6CB6 3rd i-f amplifier due to low plate voltage on this tube, preventing it from properly handling strong signals.

In initial production the screen and plate were tied together to the 150-volt line. If you encounter a set in which the plate is tied to the 150-volt line and the picture tears or rolls on strong signals, the following changes should be made to tie the plate of the 3rd video i-f tube to the 265-volt line:

1. Change the 6CB6 3rd-video i-f amplifier 82-ohm cathode resistor (*R25*) to 220 ohms, $\frac{1}{2}$ watt.

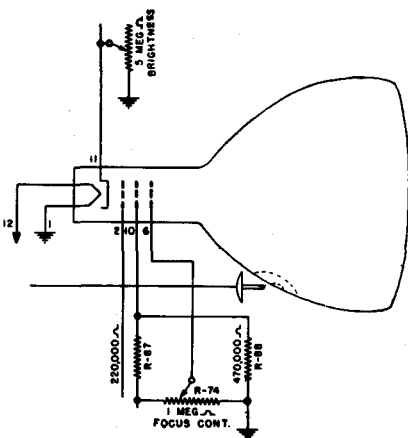

Fig. 50 — Sentinel

6CB6
3RD. VIDEO I.F.

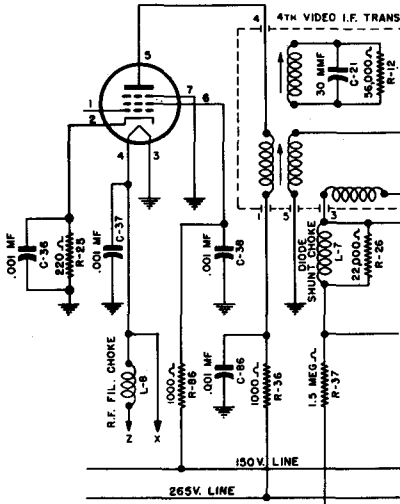

Fig. 51 — Sentinel

2. Remove the jumper wire that runs from the screen (pin 6) of the 3rd-video i-f tube to terminal 1 of the 4th video i-f transformer. This will leave the screen (pin 6) of the 3rd video i-f tube connected to the 150-volt line through a 1,000-ohm resistor.

3. Add a 1,000-ohm, 1/2-watt resistor between terminal 1 of the 4th video i-f transformer and the 265-volt line.

4. Add a .001- μ f, 500-volt capacitor (part No. 23E2025-3) between terminal 1 of the 4th video i-f transformer and chassis ground.

SENTINEL All models
Fringe-area reception.

For good fringe-area reception, the installation of an efficient antenna is important. In addition, proceed as follows:

1. Adjust the oscillator trimmer for best picture with satisfactory sound. To do this:

a. Remove the channel-switch knob and contrast-control knob. This will expose the oscillator trimmer-adjustment screws located around the channel-selector switch shaft.

b. Turn the receiver channel-selector switch to the channel on which tv station is transmitting.

c. Adjust contrast control to maximum contrast position—all the way in the clockwise direction.

d. Turn the proper oscillator trimmer-adjustment screw counter-clockwise to the point where best picture is obtained with satisfactory sound. The channel number is marked alongside each oscillator trimmer-adjustment screw.

2. Make sure that the a-c line feeding the receiver is at least 115 volts at all times. Low line voltage will affect the second-anode picture-tube voltage which will make the snow more pronounced. Always adjust the horizontal-drive control so that normal high voltage is applied to the picture tube.

SENTINEL All models
Continued ratio-detector readjustment.

There may be a need for continued ratio-detector readjustment to correct for distorted and/or weak sound. This may be due to increased leakage of the 10- μ f, 25-volt electrolytic capacitor connected across the ratio-detector output. As this capacitor becomes more and more leaky, it changes the reflected impedance into the ratio-detector tuned circuit and shifts it out of alignment. When this

capacitor gets quite leaky, the secondary adjustment peaks the sound but does not give the proper alignment setting between the two buzz peaks as it should when the circuit is normal. If this capacitor is shorted, it completely kills the audio.

To remedy, replace the leaky 10- μ f, 25-volt capacitor. It will of course be necessary to adjust the ratio-detector secondary for the best sound, between the two buzz peaks.

SENTINEL All models
Linearity-coil adjustment
 (see Fig. 52).

A simple, fast, and accurate method of adjusting the horizontal-linearity coil which does not require a station test pattern, consist of using 6—8 volt, 150-ma pilot light No. 47, with two clip leads. This is shown in part (A) of the figure.

1. Remove the high-voltage fuse from its holder in the high-voltage cage.

2. Clip a lead from the pilot light to each terminal of the fuse holder.

3. Adjust the horizontal-linearity control for minimum pilot-light brightness.

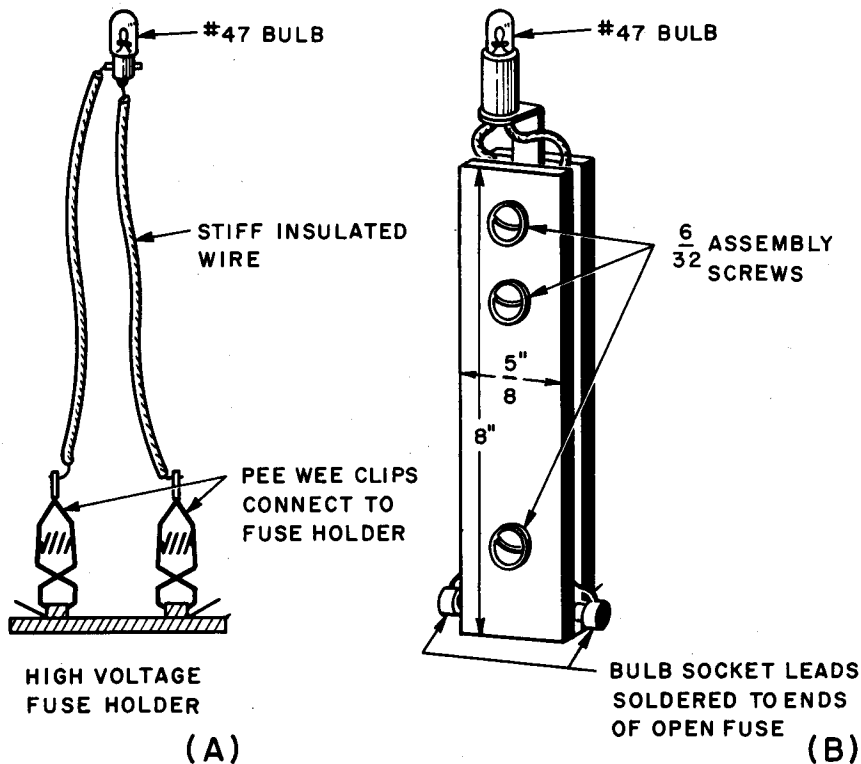

Fig. 52 — Sentinel

The above system is just as accurate as the 150-ma meter method recommended in the latest service notes. Many servicemen feel that the pilot light brightness method is easier to use.

An easy way to use this method is to make a tool that will snap into the fuse holder as shown in part (B). Use two strips of bakelite about 8" by $\frac{5}{8}$ ", fasten an open fuse in one end, and a pilot-light holder in the other as illustrated. This unit raises the light above the edge of the high-voltage cage for easier viewing.

A 200-ma bulb can also be used. It gives less light and reduced glare, and at minimum current the light almost goes out.



SETCHELL CARLSON

Chassis 152, 153, JS-167

Bend in picture.

Some 12AU7 tubes cause a permanent bend in the picture or a bend that moves slowly upward or downward—sometimes called "swim." The manufacturer has traced this to leakage between filament and other elements of the tube, thereby applying a small amount of 60-cycle ac into the horizontal-oscillator circuit. It seems that some tubes are much worse than others, and it may be that all tubes of a certain production will have an excessive amount of leakage. It is recommended, if you experience this trouble, that a new tube be used and then, if the difficulty is not corrected, try a tube of a different brand.

SETCHELL CARLSON

Chassis 152, 153

Breakdown of h-v rectifier filament wiring.

On F units in which the filament leads to the 1AX2 rectifier are made of resistance wire, heat developed within the spaghetti covering sometimes causes deterioration and breakdown of the insulation. In later units, the resistance wire has been replaced by a separate $\frac{1}{2}$ -watt resistor installed under the 1AX2 socket.

Replacement assemblies are available which include new filament wire, resistors, socket, and necessary hardware. Do not attempt to use a metal screw in place of the plastic screw provided for mounting the socket. In installing the new harness, observe the usual precautions in avoiding sharp solder projections that might cause corona. Also, avoid overheating of the high-voltage feed-through terminal to prevent softening of the plastic.

The replacement harness assemblies should be ordered by the following part Nos. TZ-201 — h-v socket and parts assembly for F5 or F6 units; TZ-202 — h-v socket and parts assembly for F3 or F4 units.

SETCHELL CARLSON

Chassis 152, 153

Improvement in vertical and horizontal hold (see Fig. 53).

The changes shown in the figure were made in Series 4 of the D unit in order to produce a steadier picture in noisy fringe areas. If an improvement in vertical and horizontal hold is required, these modifications may be made to any earlier Series D

*DENOTES CHANGE FROM SERIES 3

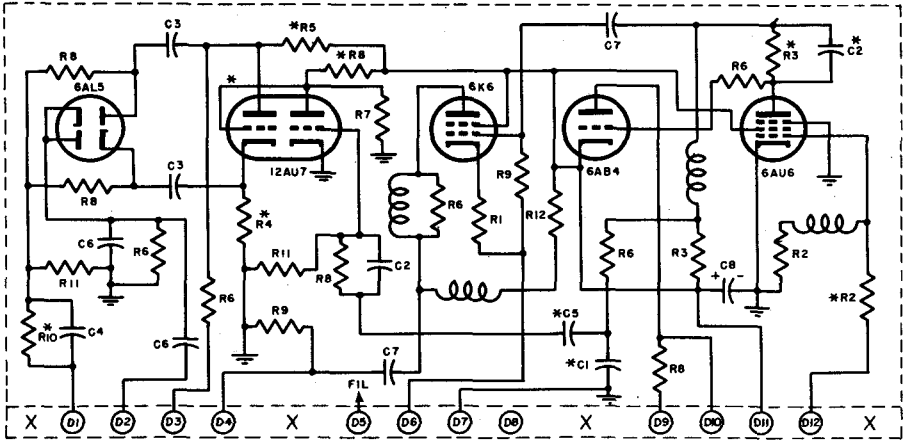

Fig. 53 - Setchell Carlson

units. Asterisks in the schematic diagram denote component changes from the previous series. Component values are as follows:

- R1** - 470-ohm, $\frac{1}{2}$ -watt resistor, tol. 10%
- R2** - 3,000-ohm, $\frac{1}{2}$ -watt resistor, tol. 5%
- R3** - 3,9000-ohm, $\frac{1}{2}$ -watt resistor, tol. 10%
- R4** - 5,600-ohm, $\frac{1}{2}$ -watt resistor, tol. 10%
- R5** - 6,800-ohm, $\frac{1}{2}$ -watt resistor, tol. 10%
- R6** - 22,000-ohm, $\frac{1}{2}$ -watt resistor, tol. 10%
- R7** - 47,000-ohm, $\frac{1}{2}$ -watt resistor, tol. 10%
- R8** - 220,000-ohm, $\frac{1}{2}$ -watt resistor, tol. 10%
- R9** - 1 megohm, $\frac{1}{2}$ -watt resistor, tol. 10%
- R10** - 2.2-megohm, $\frac{1}{2}$ -watt resistor, tol. 10%
- R11** - 4.7-megohm, $\frac{1}{2}$ -watt resistor, tol. 10%
- R12** - 3,300-megohm, $\frac{1}{2}$ -watt resistor, tol. 10%
- C1** - 20- μ f, 500-volt regular mica capacitor, tol. 10%
- C2** - 270- μ f, 500-volt regular mica capacitor, tol. 10%
- C3** - 910- μ f, 500-volt regular mica capacitor, tol. 10%
- C4** - .0027- μ f, 400-volt paper tubular capacitor, tol. 20%
- C5** - .005- μ f, 400-volt paper tubular capacitor, tol. 20%
- C6** - .01- μ f, 400-volt paper tubular capacitor, tol. 20%
- C7** - .047- μ f, 400-volt paper tubular capacitor, tol. 20%
- C8** - 10- μ f, 450-volt electrolytic tubular capacitor

SETCHELL CARLSON

Chassis 152, 153

Preventing overdrive of horizontal-output tube (see Fig. 54).

An automatic-drive arrangement may be incorporated into Series 5 of the F Hermadome unit. This arrangement, included in Series 6 of the unit, offers a great advantage in that

* DENOTES CHANGE FROM F5 HERMADOME UNIT

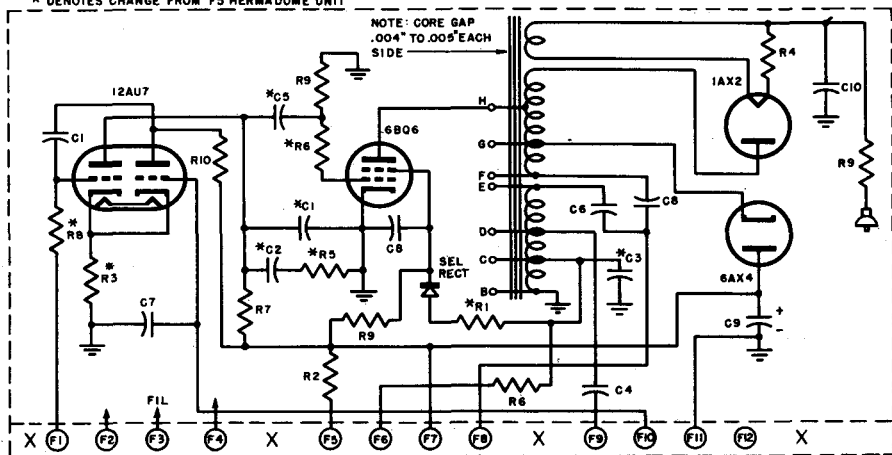

Fig. 54 - Setchell Carlson

- R1 - 150 ohm, 2 watt, tol. 10%
- R2 - 82 ohm, 1/2 watt, tol. 10%
- R3 - 560 ohm, 1/2 watt, tol. 10%
- R4 - 1.5 ohm, 1/2 watt, tol. 10%
- R5 - 15-k ohm, 1/2 watt, tol. 10%
- R6 - 22-k ohm, 1/2 watt, tol. 10%
- R7 - 100-k ohm, 1/2 watt, tol. 10%
- R8 - 120-k ohm, 1/2 watt, tol. 10%
- R9 - 1-meg ohm, 1/2 watt, tol. 10%
- R10- 27-k ohm, 1/2 watt, tol. 10%
- C1 - 270 $\mu\mu\text{f}$, 500 volt silver mica, tol. 5%
- C2 - 680 $\mu\mu\text{f}$, 500 volt silver mica, tol. 5%
- C3 - .005 μf , 400 volt tubular mica, tol. 20%
- C4 - 470- $\mu\mu\text{f}$, 500 volt regular mica, tol. 10%
- C5 - .0027 μf , 400 volt tubular, tol. 20%
- C6 - .047 μf , 400 volt tubular, tol. 20%
- C7 - .022 μf , 400 volt tubular, tol. 20%
- C8 - .22 μf , 400 volt tubular, tol. 20%
- C9 - 40 μf , 450 volt electrolytic
- C10- 500 $\mu\mu\text{f}$, 20kv ceramic

the 6BQ6 horizontal-output tube is always sufficiently driven but it is never overdriven. Such overdriving results in a vertical white line in the center of the picture tube. The schematic diagram shows the revised circuit with component changes denoted by means of asterisks. The component values used are as shown:

The purpose of screen-supply C3 is to reduce voltage produced during flyback, its use will materially reduce corona troubles as well as increase sweep width. If additional width is required C3 may be increased to as high as .01- μ f without serious reduction of high voltage.

Note: Do not employ the above circuit improvement in the F3 or F4 units.

SETCHELL CARLSON

Chassis 152, 153

Checking selenium-rectifier current when making a replacement (see Fig. 55).

When replacing a selenium rectifier in any of the models of F unit, be sure to check the rectifier current as a safety measure. The current must be held within the limits of 15 and 25 milliamperes, with 20 ma being considered optimum.

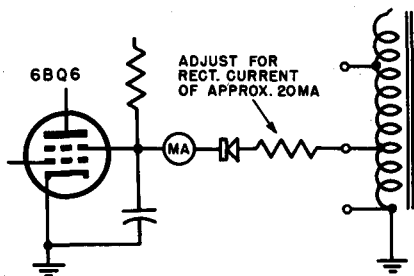

Fig. 55 — Satchell Carlson

Connect a milliammeter between the screen terminal of the horizontal-output tube socket and the selenium rectifier (see sketch). If the meter is inserted at any other point, the capacitance of the leads may cause faulty readings.

If the current measured is not within the stated limits, the series resistor must be raised or lowered accordingly. In making the test, be sure that a good horizontal-output tube is being used and that the line voltage is about 115 volts. Controls should be adjusted for a normal picture.

SETCHELL CARLSON

Chassis 152, 153

Insufficient width and horizontal foldover (see Fig. 56).

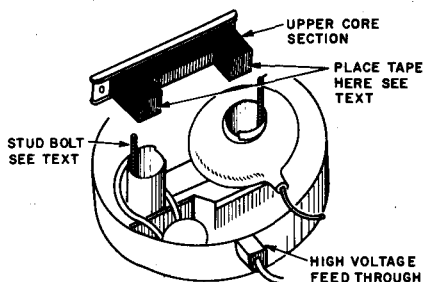

Fig. 56 — Satchell Carlson

The manufacturer has found that in some units a change in horizontal-output-transformer core characteristics takes place after the receiver has been in use, making it difficult to maintain proper sweep and linearity. In addition, horizontal foldover may occur at the right side of the raster accompanied by insufficient width.

It is essential that the core gap in the horizontal-output transformer be held within the limits of .004 to .005 inch. Two layers of Minnesota Mining #600 Scotch cellulose tape provide an excellent gap within the above tolerances. If any other material is used for gap spacing, it must be able to withstand a temperature of about 250 degrees F.

Where a transformer is found to be sweeping improperly, perform the following operations:

1. Remove the two nuts holding the upper core bracket of the horizontal-output transformer. Hold the stud bolts with a pair of pliers while loosening the nuts, or the studs may screw out of the plastic.

2. Lift out the upper half of the core. Clean off the tape originally used to space the air gap and replace it with two layers of the above tape. Be sure that the tape is applied evenly on each upper leg, (see illustration).

3. Before reinstalling the core, clean out any foreign particles that may be lying in the gap area on the lower core legs. Check the spring contact between the bottom of the core and the high-voltage filter capacitor. Increase tension of necessary.

4. Replace the core and bracket. Do not overtighten the nuts, and be sure that both ends of the bracket are pulled down evenly. Before replacing the Hermadome cover, inspect the transformer carefully. Remove any metal particles that may have fallen off the screws and which might cause flashover later. Dress the transformer leads down and away from the winding.

5. After changing the core gap, it will be necessary to increase the size of the resistor in series with the 6BQ6 screen. Remove the present 68-ohm resistor and replace it with a 150-ohm, 2-watt resistor. Or, if you wish, an additional 68- or 75-ohm, 1-watt resistor can be installed in series with the present 68-ohm resistor to produce a satisfactory total resistance.

SETCHELL CARLSON

Chassis 152, 153

H-v flash-over due to dehydrator crystals.

The manufacturer has made a study of F units which have failed in the field and has found that a surprising number of breakdowns have been caused by neglect of the silica gel dehydrator used in the Hermadome. Although the manufacturer has stressed the importance of keeping the dehydrator properly activated, it is apparent that customers (and servicemen) open the Hermadome for service without ever noting the condition of the dehydrator crystals. As a result, completely saturated crystals are allowed to remain in the unit and become a definite hazard to operation. Besides humidity due to crystals passing moisture back into the unit when heated, small particles of residue fall into the lower part of the dome to cause flash-over and eventual breakdown.

The impregnation and coating of the transformers used in the Hermadome F units are more than adequate to withstand any humidities normally encountered. Future trouble may be avoided by removal of the silica gel from any of these units serviced.

Follow this procedure:

1. Loosen the spring nut in the upper part of the dome. Remove and throw away the silica gel crystals and the retaining discs.

2. Punch or drill a small hole in the upper part of the dome at the point where the indentation seats on the clamp. You will find that the plastic at this point is thin enough to allow you to punch through with an awl or a small screwdriver. The purpose of this vent hole is to allow expanding vapors to escape and to prevent a vacuum from forming when cooling.

3. Wipe out the interior of the cover and blow out any crystal par-

ticles that may be lying in the base or on the transformer. Apply corona dope to the transformer lugs, including the ground lug on the side toward the 1AX2 socket. Also dope any bare connections noticeable on the socket itself.

Note: The dehydrator was deleted from units in later production.



SHAW TV Chassis 224
Improved horizontal centering
 (see Fig. 57).

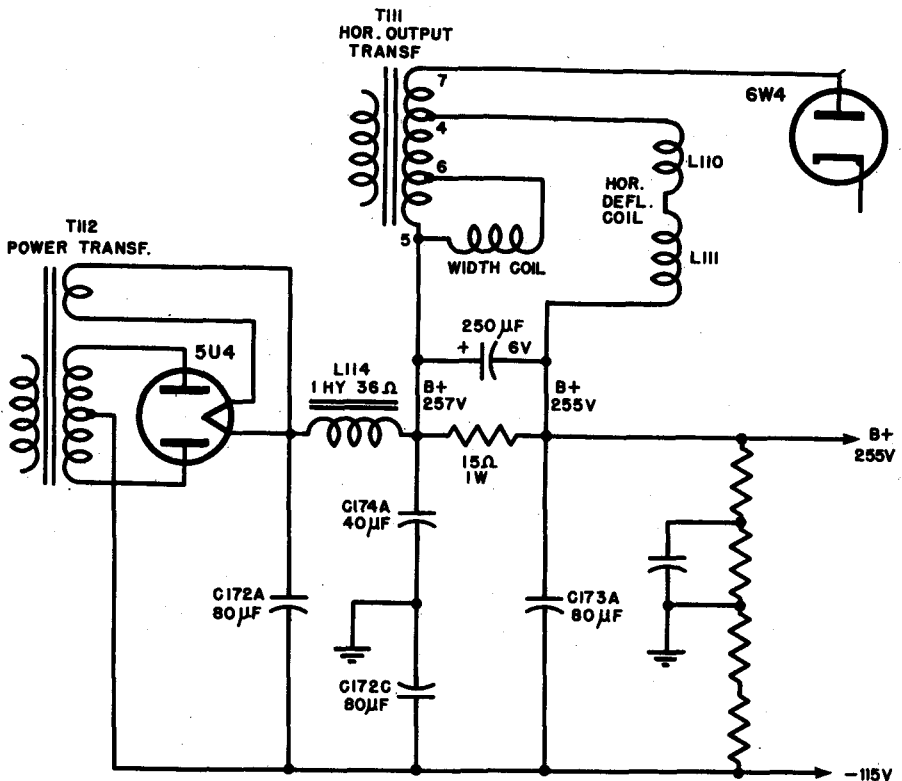

Fig. 57 — Shaw TV

Some sets will have poor horizontal centering due to cathode-ray tube (21MP4) variation. The quickest and most effective permanent solution is the following modification:

1. Remove red lead jumper from *C173A* (80 μf , 450 volts) to *C174A* (40 μf , 450 volts).

2. Remove .1- μf , capacitor, *C166* from the terminal-strip lug. This capacitor is wired between one side of the horizontal yoke and terminal 5 of the horizontal-output transformer.

3. Remove green lead which is connecting screen resistor *R203* of the 6BG6G to the black lead of the deflection-yoke plug.

4. Remove the end of the 5.1-k, 2-watt resistor (*R203*) connected to the terminal-strip lug, and connect it to the lug on that same terminal strip which is the B+ feed when the front-panel selector switch is in the TV position. This lug is next to the original position.

5. Remove the red lead coming from pin 5 of the horizontal-output transformer to the terminal-strip lug containing the B+ feed referenced above, from the terminal-strip lug, and wire onto the blank lug (to which the screen resistor *R203* was originally connected). Add a wire jumper from this lug to *C173A*.

6. Wire a 15-ohm, 1-watt, 10% resistor from *C173A* to *C174A*.

7. Wire a 250- μf , 6-volt electrolytic capacitor across the 15-ohm resistor, connecting the positive terminal to *C174A*.

8. Add a jumper from the terminal-strip lug containing the black lead from the yoke to the B+ point on the bleeder.

The above modifications were included in production runs 301-305.

SHAW TV

Chassis 224

Vertical jitter.

In the event of vertical jitter, change the timing resistor, *R180*, in the vertical-discharge network from 10 k, $\frac{1}{2}$ watt, 5% to 8.2 k, $\frac{1}{2}$ watt, 5%. This change has already been made in production runs 303-306.

SHAW TV

Chassis 224

High-voltage capacitor failure.

The high-voltage capacitor (*C164*), a 500- μf , 20,000-volt unit, may be subject to failure if not properly handled at the time of assembly, resulting in internal arcing after several weeks of operation. In production runs 301-305, the lead to the top of the capacitor was soldered to the top of the stud, and under some conditions, excessive soldering heat may also cause internal arcing. Later production uses a terminal lug fastened by a machine screw to the top of the stud.

Use this mechanical method in replacement, and avoid excessive twisting or pressure when mounting. Be sure to wipe the surface of the capacitor to prevent external leakage due to dirt or grease.

SHAW TV

Chassis 224

Buzz on either side of correct tuning position (see Fig. 58).

Buzz may occur on either side of the correct adjustment of the fine-tuning control. This effect can be eliminated by the following modification, already made in production runs 301-304.

1. Mount a single-lug terminal strip under the nut of the discriminator can (closest end to *V112* age tube).

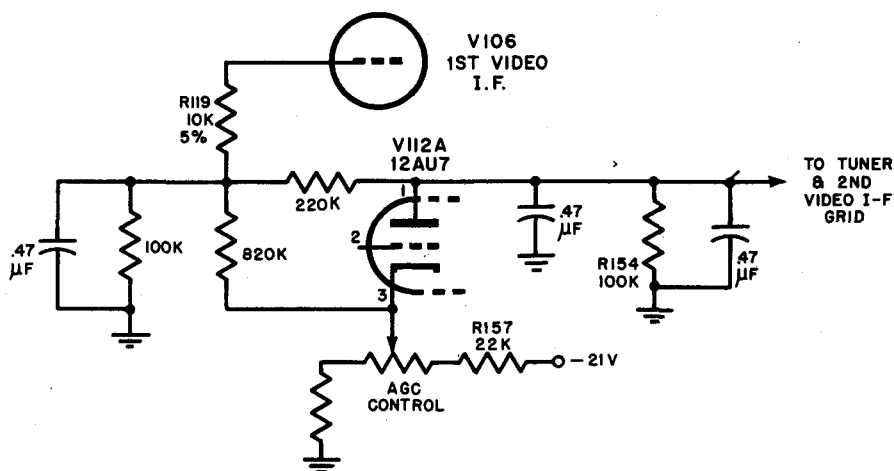

Fig. 58 — Shaw TV

2. Wire a 820-k, $\frac{1}{2}$ -watt resistor from pin 3 of *V112* to the terminal-strip lug.

3. Wire a 220-k, $\frac{1}{2}$ -watt resistor from pin 1 of *V112* to the terminal-strip lug.

4. Wire a 100-k, $\frac{1}{2}$ -watt resistor from the terminal-strip lug to the chassis ground.

5. Wire a .47- μ f, 200-volt capacitor across the 100-k resistor to chassis ground.

6. Remove from the agc end the connection of the grid resistor of the 1st-video i-f amplifier *R119* (10 k, 5%) and wire this end of *R119* to the new terminal-strip lug using a wire jumper.

7. If the agc potentiometer is at the end of its range, change *R157* from a 47-k, $\frac{1}{2}$ -watt resistor to a 22-k, $\frac{1}{2}$ -watt unit.

8. Add a .47- μ f, 200-volt capacitor from pin 1 of *V112* to chassis ground.

SHAW TV Chassis 224, XY-362 Tunable buzz in sound section.

If the brightness control is turned for maximum brightness, a buzz may be heard even with the volume control adjusted for minimum sound. This buzz is due to radiation from the metal shell of the picture tube into the chassis. Check to see that the tube shields around the 12AT7 audio amplifier and around the tubes in the front-end are in place and are properly seated and grounded.

The buzz may be very loud if the high-voltage capacitor *C164* (500 μ f at 20 kv) is open. This capacitor should be checked. It may also be helpful to change *R115*, 1.8-k cathode resistor of *V104-A* (1st audio amplifier) to 330 ohms at $\frac{1}{2}$ watt and add a .0047- μ f, 400-volt capacitor across *C112*, .0047- μ f tone-control capacitor. These changes have already been made in production runs 301-304.

INDEX

	Page		Page
A			
Agc control,		Buzz,	
<i>RCA</i> , 6T53, -54, -64, -65,		<i>RCA</i> , 8T270, 9T246, 9T270,	
-71, -74, -75, -76,		9TC245, T100, -120, -121,	
-84, -86, -87, 9T57,		-164, TA128, -129, -169,	
-77, -79, -89	6-7	TC124	12-13
17T150, -151, -153,		<i>Sears Roebuck</i> , 478 series	72-73
-154, -155, -160, -162,		478.319	75
-163, -172, -172K, -173,		549.100	80
-173K, -174, -174K,		100.107, -112	49-50
21T159, -165, -176,		<i>Sentinel</i> , 420, -23, -24,	
-177, -178, -179	15-16	-25, -28, -32, -38, -39,	
17T200, -201, -202		-40, -41, -43, -44	99-100
-211, -220, 21T208,		<i>Shaw TV</i> , 224	114-115
-217, -218, -229	23-24	audio,	
Alignment, antenna-matching,		<i>Sears Roebuck</i> ,	
<i>RCA</i> , 17T153, -154, -155,		132.890 series	70-71
-160, -162, -172, -173,		478.319	75
-174, 21T176, -177,		All chassis with	
-178, -179	21-22	focus magnet	85-86
picture i.f.,		intercarrier,	
<i>RCA</i> , 8T270, 9T246, -70,		<i>Sears Roebuck</i> ,	
9TC245, T100, -120,		110.499	59, 59-61
-121, -164, TA128,		All chassis	90-91
-129, -169, TC124	12	intermodulation,	
Antenna matching section,		<i>Sears Roebuck</i> , 132.890	72
<i>Sears Roebuck</i> , all chassis		sync,	
with 75-ohm input	88-89	<i>Sears Roebuck</i> , 132 series	65-66
Arcing,		tuneable in sound section,	
<i>Sears Roebuck</i> , 1950		<i>Shaw TV</i> , 224	115
549 series chassis	84-85		
All chassis	91		
in high-voltage section,			
<i>Sears Roebuck</i> , 110 series	58-59		
528.630, -.631, -.632	77		
picture tube,			
<i>RCA</i> , models with			
metal picture tubes	39-40		
B			
Bending, picture,			
<i>RCA</i> , 6T53, -54, -64, -65,			
-71, -74, -75, -76,			
9T89, -147, 16T152	9		
<i>Sears Roebuck</i> ,			
549.102 series	83		
<i>Setchell Carlson</i> , 152, 153	108		
Bounce, vertical,			
<i>Sears Roebuck</i> , 478.303	75		
Brightness,			
<i>RCA</i> , 9TW390, S1000	14		
<i>Sears Roebuck</i> , 101.865,			
-866, -867, -868	57		
C			
Centering adjustment,			
<i>Sears Roebuck</i> ,			
132.890 series	70		
All chassis with			
focus magnet	86		
horizontal,			
<i>Sentinel</i> , 412, -13, -15	97		
<i>Shaw TV</i> , 224	113-114		
Contrast, improving,			
<i>Sentinel</i> , 454, -55, -56, -57	105		
Contrast control, action,			
<i>Sears Roebuck</i> , 478.321,			
-339, -361	75		
Crystal detector, failure,			
<i>Sentinel</i> , 454,			
-55, -56, -57	104-105		
replacement,			
<i>RCA</i> , 17T150, -151, -153,			
-154, -155, -160, -162,			
-163, -172, -172K, -173,			
-173K, -174, -174K,			
21T159, -165, -176,			
-177, -178, -179	16		

	Page
D	
Deflection, horizontal, <i>Scott</i> , 710, 720, 910, 920, 924	45-46
Double pulsing, horizontal, <i>Sears Roebuck</i> , 110.700-120, -140	64
132.889	67
Drift, horizontal, <i>Sears Roebuck</i> , 478 series	73-74
F	
Filter, high-pass, <i>RCA</i> , model with KRK2, -5, -7, -8 tuners	29-30
Focus, <i>RCA</i> , models with 17GP4 picture tubes	38-39
Focus coil, EM-PM, <i>RCA</i> , all models with EM-PM focus coils	40-41
Focus control, range, <i>Sentinel</i> , 412, -13, -15	97
Foldover, horizontal, see Width, increasing vertical, see Vertical scan	
Fringe area, contrast, <i>RCA</i> , all models	41
modifications for, <i>RCA</i> , 8T241, -243, -244	10-12
operation, <i>RCA</i> , 6T72, T164, TA128, -129, -169, TC124, -125, -127, -165, -166, -167, -168	9-10
17T200, -201, -202, -211, -220, 21T208, -217, -218, -227, -228, -229	23
sensitivity, <i>Sears Roebuck</i> , 101.846, -854	55
<i>Sentinel</i> , all models	106
sound and picture, <i>RCA</i> , 17T150, -151, -153, -154, -155, -160, -162, -163, -172, -172K, -173, -173K, -174, -174K, 21T159, -165, -176, -177, -178, -179	17-18
sound gain, increasing, <i>RCA</i> , 4T101, -141, 7T103, -104, -111, -112, -122, -123, -124, -125, -132, -143, 9T105, -126, -128, -147	5-6
sync stability, <i>Sears Roebuck</i> , 100.208	53
vertical stability, <i>Sears Roebuck</i> , 100.107, -111, -115, -120	47-48
110.700 series	62-68
Fuse, failure, <i>Sentinel</i> , 438, -39, -40, -41, -43, -44	103, 104

replacement, <i>RCA</i> , 17T150, -151, -153, -154, -155, -160, -162, -163, -172, -173, -174, 21T159, -165, -176, -177, -178, -179	18-19
<i>Sears Roebuck</i> , 528.630, -.631, -.632	77
H	
Height, excessive, <i>Philharmonic</i> , 111, 112, 724-924-924, 820-920, 1116, 5221, 5816, 8120-9120, 8820-9820, 20C2B, 20CD2B, 20T2B, C-6161, T-616	2
insufficient, <i>Sears Roebuck</i> , 132.890	69
549.102	83-84
High-noise area, <i>Remington</i> , 80, 130	45
<i>Sears Roebuck</i> , all chassis	91-93
High-voltage disabling, <i>Sears Roebuck</i> 101.846, -854	54
feedback, <i>Sears Roebuck</i> , 110.700 series	62
Hold, horizontal, <i>Sears Roebuck</i> , 110.499	59-60
<i>Sentinel</i> , 401, -2, -6, -7, -9, 411 through 416, 419 through 425, 428	95
412, -13, -14, -15	96
vertical, <i>Sears Roebuck</i> , 110.499	59
Horizontal-drive control, <i>Philharmonic</i> , 111, 112, 724-924-924, 820-920, 1116, 5221, 5816, 8120-9120, 8820-9820, 20C2B, 20CD2B, 20T2B, C-6161, T-616	1
<i>Radio and Television</i> , 616, 1116, 6161	5
<i>Sentinel</i> , 438, -39, -40, -41, -43, -44	103
Hum, <i>Pilot</i> , TV-271, -164, -167A, -167B, -168, -191, -192, 271, 273, 274, 293, 294	3
<i>Sears Roebuck</i> , 110 series	58
110.700	64
all chassis	90
audio, <i>Sears Roebuck</i> , 549.102	84
on phono operation, <i>RCA</i> , S1000, TA169	24-25
pick-up, <i>Sears Roebuck</i> , 478.338	75-76

	Page
I	
Interference,	
<i>RCA</i> , all models	41-44
<i>Sears Roebuck</i> , 132.890	68, 72
broadcast,	
<i>RCA</i> , models with KRK5, -7	33
channel 7,	
<i>Sears Roebuck</i> , 132.890	69
corona,	
<i>RCA</i> 9T57, -77, -79, -89	13
i-f harmonic,	
<i>RCA</i> , models with	
KRK5, -7 tuners	33-35
in f-m receivers,	
<i>Sears Roebuck</i> , all chassis	93-94
see also: Lines	
Interlace,	
<i>Sears Roebuck</i> , 110.499	59
132.890	69, 72
Ion traps,	
<i>Sears Roebuck</i> , 1141-20	85
all chassis with	
electrostatic picture tubes	86-87
all chassis	90
J	
Jitter, horizontal,	
<i>Pilot</i> , TV-127, -164, -167A,	
-167B, -168, -191, -192	3
<i>Sears Roebuck</i> , 110.700	64
100.700-1 through -140	54
100.700-90	65
vertical,	
<i>Sears Roebuck</i> , 100.499	53
110.700 series	61
<i>Shaw TV</i> , 224	114
L	
Lines, black, at top of picture,	
<i>Sears Roebuck</i> , 107.111, -121	49
vertical,	
<i>Pilot</i> , TV-127, -273, -274,	
-293, -294	3-4
Linearity, horizontal,	
<i>Sears Roebuck</i> , 110.499	59
528.630, -631	78
vertical,	
<i>RCA</i> , T120	126-127
Low-line voltage areas,	
<i>Sears Roebuck</i> , 478.338	76
N	
Noise, lead-in mismatch,	
<i>Sears Roebuck</i> , 110.700-2	65
Noisy area, vertical stability,	
<i>Sears Roebuck</i> ,	
132.890 series	70

	Page
O	
Oscillation, amplifier,	
<i>RCA</i> , T164, TC165,	
-166, -167, -168	27
Barkhausen,	
<i>RCA</i> , all models	41
parasitic,	
<i>Philharmonic</i> , 111, 112,	
724-924-924, 820-920,	
5221, 8120-9120,	
20C2B, 20CD2B, 20T2B,	
8820-9820	2
Oscillator, vertical drift,	
<i>Sears Roebuck</i> , 478.339, -361	76
wafer, tuner switch,	
<i>RCA</i> , 17T150, -151, -153,	
-154, -155, -160, -162,	
-163, -172, -172K, -173,	
-173K, -174, -174K,	
21T159, -165, -176,	
-177, -178, -179	16-17
P	
Phasing, horizontal,	
<i>Sears Roebuck</i> , 110.700	64
Picture controls, interaction,	
<i>Sears Roebuck</i> , 110.700 series	61
Picture jagged (pie-crust)	
<i>Sears Roebuck</i> , 478.338	75
Picture quality, improving,	
<i>Sears Roebuck</i> , 100.120	51
Picture-tube, beam current,	
<i>Sears Roebuck</i> , 100.120	51-52
dust seal,	
<i>RCA</i> , all models with	
16-, 17-, 19-, and	
21-inch picture tubes	36
focus magnet,	
<i>RCA</i> , models with 19AP4A	
picture tubes	39
operation, low-line voltage,	
<i>Philharmonic</i> , 111, 112,	
724-924-924, 820-920,	
5221, 8120-9120,	
20C2B, 20CD2B, 20T2B	2-3
replacement,	
<i>Sentinel</i> , 420	101-102
substitution,	
<i>RCA</i> , models with 10BP4,	
12LP4, 16AP4	
picture tubes	35-36
17CP4 picture tubes	37-38
Pulling, horizontal,	
<i>Sears Roebuck</i> , 100.208	52
549.100 series	81
R	
Raster, black bars on left,	
<i>Philharmonic</i> , 111, 112,	
724-924-924, 820-920,	

	Page
1116, 5221, 5816, 8120-9120, 8820-9820, 20C2B, 20CD2B, 20T2B, C-6161, T-616	1-2
displaced vertically, Sears Roebuck, 132.889	68
kinky, RCA, T164, TC165, -166, -167, -168	27
ringing, RCA, T100, -120, TC124, -125, -127, TA128, -129	25-26
Ratio-detector adjustment, Sentinel, all models	106-107
Response, video i-f, RCA, models with KRK5, -7, -8 tuners	32
Retrace line, Sentinel, 412, -13, -15 Sears Roebuck, 110.700	97-98 64
suppression, Sears Roebuck, 110.700	62
Ringing, Sears Roebuck, 100.120	51
Rolling, on strong signals, Sentinel, 454, -55, -56, -57	105-106
vertical, Sears Roebuck, 100.208	53
S	
Scan, vertical, insufficient, Sears Roebuck, 549.100-5	82
Sensitivity, improving, Sears Roebuck, 100.107, -111, -112, -115, -120, -121 478.339B, -361A, -375, -376	47 76-77
Shadow, RCA, T120, TC124, -125, -127 Sentinel, 420, -23, -24 402CV, 406CV, 411CV 425	26 101 95-96 102-103
Shock hazard, Sears Roebuck, 100.208, -209 101.846, -854	52 54
Short circuit, RCA, models with KRK11	35
Shrinkage, vertical, Sears Roebuck, 549.100 series	80-81
Size, horizontal, increasing, Sears Roebuck, 101.846, -854	54-55
vertical, Sentinel, 454, 455, 456, 457	105
Smear, Pilot, TV-127, -164, -167A, 167B, 168, 191, 192	3

	Page
RCA, 16T53, -54, -64, -65, -71, -74, -75, -76, -84, -86, -87, 9T57, -77, -79, -89	14-15
Sears Roebuck, 132.890 478.339, -361	72 76
Snow, RCA, 17T153, -154, -155, -160, -162, -172, -173, -174, 21T176, -177, -178, -179	20-21 57-58
Sears Roebuck, 106 series	57-58
Sound, distorted or weak, RCA, 6T53, -54, -64, -65, -71, -75, -76, 7T103, -104, -111, -112, -122, -123, -124, -132, 9T89, -147, 16T152	7 99
Sentinel, 419, -20, -23, -24, -25, -28	99
Sound and gain, RCA, 6T53, -54, -64, -65, -71, -74, -75, -76, -84, -86, -87, 9T57, -77, -79, -89	6
Squeal, high-frequency, Sentinel, 419, -20, -23, -24, -25, -28	99
unused channel, Sears Roebuck, 100.120, -121	50-51
Stability, horizontal, Sears Roebuck, 100.499 110.700 series 110.700-1 110.702-10, -50 132.890 series 528.630, -631 549.101 series Sentinel, 416	53 61-62 65 65 70 78 82 98-99
vertical, Sears Roebuck, 100.107 132.890	50 69
Static discharge, Sears Roebuck, 100.208, -209	52
Strong-signal area, rolling, Sears Roebuck, 549.102	83
Sync, improvement, Sears Roebuck, 100.208 Setchell Carlson, 152, 153	52-53 108-109
horizontal, RCA, 9TC245, -247, -249, T121	13-14
vertical, RCA, 9TC245, -247, -249, T121 17T153, -154, -155, -160, -162, -172, -173, -174 21T159, -165, -174, -176, -177, -178, -179	13 22-23 24

	Page
6T53, -54, -64, -65, -71, -75, -76, 7T103, 104, -111, -112, -122, -123, -124, -132, 9T89, -147, 16T152	6-9
Sears Roebuck, 100.120	51
T	
Tearing, Sentinel, 400, -1, -2, -5, -6, -11	94-95
Tone control, Sentinel, 438, -39, -40, -41, -43, -44, -46, -47, -48, -49, -50, -51	103
Tracking, tuner, oscillator, RCA, models with KRK2, -5, -7, -8 tuners	30-31
Transformer, Philharmonic, 61, 616, 6816	1
Radio and Television, 616, 1116, 6161	4
first picture i.f., RCA, 9T246, 9TC245, T121	13
horizontal output, Sears Roebuck, 132.889	67
picture i-f adjustment, RCA, 17T153, -154, -155, -160, -162, -172, -173, -174, 21T176, -177, -178, -179	19
power, Sentinel, 438, -39, -40, -41, -43, -44	103
vertical output, Sears Roebuck, 132.890	69
Transmission line, RCA, models with KRK2 tuners	32
Trap, 4.5 mc. installation, Sears Roebuck, 101.846	55-56
adjacent-channel sound, Sears, Roebuck, 100.107, -111, -112, -115, -120, -121	46-47
Tube, audio output, Sentinel, 401, -2, -6, -11	95
failure, 12BH7, Sears Roebuck, 110.700 series	63, 63-64
high voltage, Sears Roebuck, 132.890 series	69-70
Setchell Carlson, 152, 153	108
horizontal output, Sears Roebuck, 132.889	66-67
Setchell Carlson, 152, 153	110-111

	Page
low voltage, Sentinel, 438, -39, -40, -41, -43, -44	103-104
replacement, RCA, 17T150, -151, -153, -154, -155, -160, -162, -172, -173, -174	19
Setchell Carlson, 152, 153	111
socket connections, 1X2, Sears Roebuck, all chassis with 1X2	88
Tuner cover, removal, Sears Roebuck, 528.631	79-80
Tweet modulation, Sears Roebuck, all chassis with built-in antenna	88

V

Voltage, breakdown, Radio and Television, 616, 1116, 6161	4-5
oscillator injection, RCA, models with KRK11 tuner	35
vertical sawtooth, Sears Roebuck, 132.890	68-69

W

Width, increasing, RCA, T164, TC165, -166, -167, -168	28-29
Sears Roebuck, 110.700-900	65
132.890 series	70-72
Sentinel, 420, -23, -24, -25, -28	100-101
Setchell Carlson, 152, 153	111-112
Width coil, failure, Sears Roebuck, 100.107, -111, -112	48-49
549.100-8, -9	82
549.102	82-83
Wiggle, horizontal, Sears Roebuck, 110.700 series	61
vertical, Sears Roebuck, 132.889	67

Y

Yoke, deflection, RCA, T100, -120, TC124, -125, -127, TA128, -129	25
7T103, 17T153, -154, -155, -160, -162, -172, -173, -174	10

Make TV servicing EASY!

TV MANUFACTURERS' RECEIVER TROUBLE CURES

Volumes 1, 2, 3 and 4

Only \$1.80 each volume

Volume 5 in preparation

TV TROUBLESHOOTING AND REPAIR GUIDE BOOK, VOL. 1

by Robert G. Middleton

Know how to recognize TV receiver troubles and cure them. This book shows you how through the use of pictures taken directly from TV receiver picture tubes and scopes. Valuable troubleshooting charts are also given. Not a theory book—but a practical troubleshooting and repair guide guaranteed to save hours of time-consuming labor. 204 pages, 8½" x 11", illus. *Only \$3.90.*

RECEIVING TUBE SUBSTITUTION GUIDE BOOK

by H. A. Middleton

Answers all tube problems by listing 2,500 radio-television tube substitutions in numerical sequence with accompanying wiring instructions, original and substitute tube socket illustrations. It helps you turn out jobs that would otherwise remain on the shelf because of lack of proper tubes. 224 pages, 8½" x 11". *Only \$3.00.*

FIRST SUPPLEMENT, RECEIVING TUBE SUBSTITUTION GUIDE BOOK

by H. A. Middleton

750 completely new and different radio-TV tube substitutions not listed in the first edition. Special section on substituting tubes in television receivers. 48 pages, 8½" x 11". *Only 99¢.*

TV SWEEP ALIGNMENT TECHNIQUES

by Art Liebscher

Never before has there been a book such as this on TV sweep alignment! An expert gives you accurate time-saving methods—and tells you how they work. The new *Supermark* method is introduced. Chock-full of sweep curve pictures. Valuable for servicing in UHF areas. 123 pages, 5½" x 8½", illustrated. *Only \$2.10.*

To be Published Soon

HOW TO USE METERS

by John F. Rider

Panel type, volt-ohm-milliammeter, vacuum tube voltmeter for servicing TV and radio receivers, audio amplifiers, power supplies; for use and repair of amateur transmitters. Written for the service technician, TV and radio student, and ham.

Over 140 pages, illus., 5½" x 8½", Only \$2.40

Obtaining and Interpreting TEST SCOPE TRACES

by John F. Rider

Over 500 actual photographs of test scope traces. Shows how to use scopes and what the traces mean! Valuable for servicing FM, AM, and TV receivers, audio systems and test equipment. Test equipment set-ups.

Over 140 pages, illus., 5½" x 8½", Only \$2.40

HOW TO USE SIGNAL AND SWEEP GENERATORS

by J. Richard Johnson

First book to devote itself entirely to all types of signal and sweep generators. Gives test uses and discusses problems in using this equipment and how to overcome them. Completely explains all applications of all signal and sweep generators used in AM, FM, radio and TV servicing. Over 120 pages, 5½" x 8½". *Only \$2.10.*

Scanned by mbea2k - Dec 2011

JOHN F. RIDER PUBLISHER, INC., 480 CANAL ST., N. Y. 13, N. Y.