

Introduction

I found these books to be very helpful for specific problems and troubles as found and documented by the TV manufacturers themselves during the 50's. I decided they would be helpful to others in the hobby of fixing up and obsessing over old TV's like myself. Please let me know if you see any issues with the scans or need clarification on something that is not clear/visible in a scan.

From the general preface:

This is a series of volumes which deal with specific TV receiver troubles and their cures. These trouble cures are the TV manufacturers' answers to some of the problems that may arise in their particular receivers.

After a certain model or chassis has been in the field for a while, certain troubles may occur which are peculiar to that receiver. In an effort to maintain his own good reputation, the manufacturer is interested in keeping his receiver in tip-top working order. Therefore, his service or engineering department evolves a cure for the particular trouble.

The question may be asked, "Why doesn't the manufacturer incorporate the cure into future production runs on his own receiver? The answer is that he frequently does. However, it is certainly not possible, with such a complex device as a TV receiver, to hold off on production until every single "bug" has been removed. The fact remains that many receivers are in the field and do develop certain peculiarities of operation for which the manufacturer has a definite tried-and-tested cure. Many of these cures will be found in these volumes.

In addition, the development of new ideas and circuitry is unending. These new ideas are conceived by TV receiver manufacturers and many of the circuits can be incorporated into receivers already in the field. Such changes will improve the operation of the receiver, especially under unusual or difficult operating conditions. What is more, in areas of high humidity, in fringe areas, in strong-signal areas, etc., certain troubles are apt to occur. Many of the manufacturers' trouble cures given in this volume will alleviate these troubles when properly applied to the receiver in question.

You will note that these volumes contain valuable information relating to trouble cures and circuit changes which will actually improve the operation of the TV receiver. You will not be given generalized instructions to "check this capacitor" or "check that tube" if a certain trouble appears. Instead, you will be given exact directions as to the specific operation to be performed in affecting the cure. In all cases where components are identified, the manufacturers own circuit symbol is used. This makes it easy to utilize the information given in these pages along with Rider Manuals and Tek-File. A complete index in which trouble cures are listed by brand and chassis or model number appears at the end of this volume.

Volumes

There are seven volumes available (that I know about). Volumes 1-5 cover most sets and were published between 1953 and 1954. Volumes 6 and 7 cover newer sets in 1954 and 1955 and include some updates for brands covers in earlier volumes.

Volume 1			
Cat. No. 143-1, 115 Pages, Published January, 1953			
Admiral	Air King	Andrea	Arvin
Belmont-Raytheon	Bendix	Calbest	Caphart-Farnsworth
CBS-Columbia	Certified	Crosley	DuMont

Volume 2			
Cat. No. 143-2, 117 Pages, Published February, 1953			
Emerson	Fada	Firestone	Freed
Gamble-Skogmo	General Electric	Hallicrafters	Hoffman
Industrial TV	International TV	Jackson	
Volume 3			
Cat. No. 143-3, 119 Pages, Published April, 1953			
Kaye-Halbert	Kent	Magnavox	Majestic
Meck	Mercury	Midwest	Montgomery Ward
Motorola	Muntz	National	North American Philips
Olympic	Pacific Mercury	Packard-Bell	Philco

Volume 4			
Cat. No. 143-4, 120 Pages, Published July, 1953			
Philharmonic	Pilot	Radio and Television (Brunswick)	RCA Victor
Remington (Rembrandt)	Scott	Sears Roebuck	Sentinel
Setchell Carlson	Shaw TV		

Volume 5			
Cat. No. 143-5, 119 Pages, Published March, 1954			
Sparton	Stewart-Warner	Stromberg-Carlson	Sylvania
Tele King	Trad TV	Transvision	Trav-ler
Wells-Gardner	Western Auto (Truetone)	Westinghouse	Zenith

Volume 6			
Cat. No. 143-6, 120 Pages, Published November, 1954			
Admiral	Aimcee (AMC)	Arvin	Bendix
Cadillac TV	Capehart	CBS-Columbia	Conrac
Crosley	DuMont	Emerson	Firestone

Volume 7			
Cat. No. 143-7, 112 Pages, Published June, 1955			
General Electric	Hallicrafters	Hoffman	Jackson
Kaye-Halbert	Magnavox	Majestic	Mars TV
Mattison TV	Meck	Montgomery Ward	Motorola
Muntz	Pacific Mercury	Packard-Bell	Philco
Philharmonic	Radio Craftsmen	Raytheon	

All volumes scanned by mbear2k (Mark) - mbear2k@oldtubes.net

TV

MANUFACTURERS' RECEIVER TROUBLE CURES

VOLUME 7

(CAT. NO. 143-7)

General Electric
Hallicrafters
Hoffman
Jackson
Kaye-Halbert
Magnavox
Majestic
Mars TV
Mattison TV
Meck
Montgomery Ward
Motorola
Muntz
Pacific Mercury
Packard-Bell
Philco
Philharmonic
Radio Craftsmen
Raytheon

A RIDER Publication

Copyright 1955 by

JOHN F. RIDER PUBLISHER, INC.

*All rights reserved including that of translation into
the Scandinavian and other foreign languages.*

Library of Congress Catalog Card Number: 53-698

Printed in the United States of America

P R E F A C E

This is the seventh in a series of volumes which deal with specific tv receiver troubles and their cures. These trouble cures are the tv manufacturers' own answers to some of the problems that may arise in their particular receivers.

The material contained in this latest volume comprises cures dealing with later model receivers than were covered previously. In addition, some new cures which have been evolved for earlier receivers are included.

After a certain model or chassis has been in the field for a while, certain troubles may occur which are peculiar to that receiver. In an effort to maintain his own good reputation, the manufacturer is interested in keeping his receiver in tip-top working order. Therefore, his service or engineering department evolves a cure for the particular trouble.

The question may be asked, "Why doesn't the manufacturer incorporate the cure into future production runs of his own receiver?" The answer is that he frequently does. However, it is certainly not possible, with such a complex device as a tv receiver, to hold off on production until every single "bug" has been removed. The fact remains that many receivers are in the field and do develop certain peculiarities of operation for which the manufacturer has a definite tried-and-tested cure. Many of these cures will be found in this volume.

In addition, the development of new ideas and circuitry is unending. These new ideas are conceived by tv receiver manufacturers and many of the circuits can be incorporated into receivers already in the field. Such changes will improve the operation of the receiver, especially under unusual or difficult operating conditions. What is more, in areas of high humidity, in fringe areas, in strong-signal areas, etc., certain troubles are apt to occur. Many of the manufacturers' trouble cures given in this volume will alleviate these troubles when properly applied to the receiver in question.

You will note that this volume contains valuable information relating to trouble cures and circuit changes which will actually improve the operation of the tv receiver. You will not be given generalized instructions to "check this capacitor" or "check that tube" if a certain trouble appears. Instead, you will be given exact directions as to the specific operation to be

performed in effecting the cure. In all cases where components are identified, the manufacturer's own circuit symbol number is used. This makes it easy to utilize the information given in these pages along with Rider Manuals and Tek-File.

For your convenience, a cumulative Table of Contents is found at the beginning of this volume. This Table of Contents not only lists the models and chassis referred to herein, but, in addition, where cures for these and other models made by the same manufacturer appear in earlier volumes of this series, reference to such earlier volumes is also included. A complete index in which the trouble cures found in this volume are listed by brand and chassis or model number appears at the end of this volume.

The editor wishes to acknowledge the cooperation of the following tv receiver manufacturrs and/or distributors who furnished much of the information contained in this volume to John F. Rider Publisher, Inc.

GENERAL ELECTRIC	MECK
HALLICRAFTERS	MONTGOMERY WARD
HOFFMAN	MOTOROLA
JACKSON	MUNTZ
KAYE-HALBERT	PACKARD BELL
MAGNAVOX	PACIFIC MERCURY
MAJESTIC	PHILCO
MARS TV	PHILHARMONIC
MATTISON TV	RADIO CRAFTSMEN
	RAYTHEON

June, 1955

Milton S. Snitzer

CUMULATIVE TABLE OF CONTENTS

This Cumulative Table of Contents lists models of the manufacturers given below, whether cures for these models appear in this or in earlier volumes of this series.

Mfr. Model or Chassis	Vol.	Page	Mfr. Model or Chassis	Vol.	Page
General			17T10	7	4-5
Electric	2	33-54	17T11	7	4
	7	1-9	17T12	7	4
10C101	2	33	17T15	7	2-3
10C102	2	33	17T17	7	2-4
10T1	2	33-34	19C101	2	45
10T4	2	33-34	20C105	7	5-6
10T5	2	33-34	20C106	7	5-6
10T6	2	33-34	20C107	7	1-2
12C107	2	33-34	20C150	7	7
12C108	2	33-34	20C151	7	6-6
12C109	2	33-34	21C200	7	5-6
12K1	2	33-35	21C201	7	1, 2, 7
12T3	2	33-34	21C202	7	1, 2, 7-8
12T4	2	33-34	21C204	7	1, 2, 7-8
12T7	2	33-35	21C206	7	1, 2, 7-8
14C102	2	36-39	21C208	7	1, 2, 7-8
14C103	2	36-39	21C210	7	1, 2, 7-8
14T2	2	36-39	21C214	7	1, 2, 7-8
14T3	2	36-39	21C225	7	7-8
16C103	2	36-37	21C226	7	7-8
16C104	2	36-37	21C227	7	7-8
16C110	2	35, 37-40	21C228	7	7-8
16C111	2	35, 37-40	21C229	7	7-8
16C113	2	36-39	21C230	7	7-8
16C114	2	36-37	21C231	7	7-8
16C115	2	35, 37-40	21C232	7	7-8
16C116	2	37-39	21C233	7	7-8
16K series	2	35-36	21T1	7	1-2, 7
16K1	2	35, 38-41	21T2	7	4-6
16K2	2	35, 38-41	21T3	7	1-2
16T series	2	35-36	21T4	7	8
16T1	2	35, 37-40	21T5	7	5, 8
16T2	2	35, 37-40	21T6	7	1-2
16T3	2	36-37	21T10	7	2-4, 8
16T4	2	36-37	21T11	7	8
16T5	2	36-37	21T12	7	2-3
16T6	2	36-37	21T14	7	2-4
17C series	2	35-36	21T15	7	2-3
17C101	2	36	21T19	7	2-3
17C102	2	36	21T20	7	7-8
17C110	2	41-43	21T21	7	7-8
17C111	2	41-43	24C101	7	6-7
17C113	2	43-45	25C101	7	8-9
17C115	2	43-45	800 series	2	46
17C117	2	43-45	801	2	46-47
17C120	2	43-45	802	2	46-47
17C125	7	1-2	803	2	46-47
17C127	7	2-4	805	2	46, 48
17T series	2	35-36	806	2	46, 48
17T7	2	43-45	807	2	46, 48
			809	2	46, 48

Mfr. Model or Chassis	Vol.	Page
810	2	46-51
811	2	46-51
814	2	46-51
817	2	46-48
818	2	34-35, 48
820	2	46-48, 51-52
821	2	46, 48
830	2	46-49, 51
835	2	46-49, 51
840	2	46-48, 52
901	2	52
910	2	52
Models with "B-version" head-end unit		
2	2	52-53
All models using series filaments		
2	2	53
All models		
2	2	53-54
Hallcrafters		
2	2	54-56
7	7	9-12
A1100D		
7	7	9
F1100D		
7	7	9
G1100D		
7	7	10
T54	2	54
T60	2	54
T64	2	54-55
T67	2	54
T68	2	54
505	2	54
509	2	54-55
1002	2	55-56
1007	2	55-56
1015	2	55-56
1016	2	55-56
1017	2	55-56
1018	2	55-56
1019	2	55-56
1100D	7	10
1200D series	7	10-12
All 10-inch picture tube models		
2	2	56
Hoffman		
2	2	56-100
7	7	12-21
135	2	56-59
140	2	59-68
142	2	59-68
143	2	59-65, 68-70
146	2	59-68, 70-71
147	2	59-65, 68-69
149	2	68
150	2	68
151	2	68-69
152	2	69
153	2	71
154	2	68
156	2	71-73
157	2	71-73
159	2	71-81
160	2	71-81
164	2	71-73

Mfr. Model or Chassis	Vol.	Page
170	2	73-75, 81-92
171 series with uhf strip		
7	7	12
171	2	73-75, 81-92
172	2	73-75, 81-92
173	2	73-75, 81-92
174	2	73-75, 81-92
175	2	73-75, 81-92
176	2	73-75, 81-92
180	2	73-75, 81-84
183	2	73-75, 81-84, 92
184	2	73-75, 81-84
185	2	73-75, 81-84
186	2	73-75, 81-84
187	2	73-75, 81-84, 92-94
187B	2	92-94
187C	2	92-93
190 series		
7	7	13-14
190	7	12-13
191	7	12-13
192	7	12-13
196 series		
7	7	14
196	7	15
200	7	15
201	7	15
202	7	15
210	7	15
211	7	15
212	7	15
213	7	15
301	7	16-17
302	7	16-17
303	7	16-17
306	7	16-18
307	7	16-18
308	7	16-18
407	7	18-19
408	7	18-19
410	7	18-19
Mark IV chassis		
2	2	94
Chassis with tuners 9684, 9716, 9717, and 99532		
7	7	19
Chassis with turret tuners RF-3, RF-4, RF-5, RF-6		
2	2	96
Models with RF-1 head end		
2	2	94
Models with RF-2 head end		
2	2	94-95
Models with RF-3 head end		
2	2	95-96
All 19-, 12-, 16-, and 19-inch chassis		
2	2	96-98
All chassis with signal-keyed agc		
2	2	98-99
All chassis with 16-inch picture tubes		
2	2	98
All chassis		
2	2	99-100
2	2	20

Mr. Model or Chassis	Vol.	Page
Jackson	2	109-110
	7	20 21
114G	2	109-110
116G	2	109-110
117G	2	109-110
120G	2	109-110
317A	7	20-21
320A	7	20-21
321A	7	20-21
324A	7	20-21
Kaye-Halbert	3	1-4
	7	21
231	3	1-2
242	3	1-2
253	3	1-2
263	7	21
21-inch chassis	3	3
1952 chassis	3	3-4
Magnavox	3	4-8
	7	21-32
CT214	3	4-8
CT218	3	4-6
CT221	3	4-6
CT247	3	8
CT248	3	8
CT249	3	8
103 series	7	21-22
104 series	7	22-23
105 series	7	23-29
105N series	7	29
106	7	23-27
107 series	7	23-27, 29
108 series	7	29-30
250 series	7	30-31
300 series	7	31
300 series with separate audio amplifier	7	31
All chassis with uhf	7	32
All chassis with 700458-1 tuner	7	32
All chassis with 74-degree picture tube	7	32
All models with grill cloth	3	8
Majestic	3	8-12
	7	32-34
94	3	8-10
97	3	8-10
98	3	8-10
99	3	10-12
100	3	11-12
101	3	11-12
102	3	11-12
103	3	10-12
105	3	10-12
112 series	7	32-33

Mr. Model or Chassis	Vol.	Page
113 series	7	32-33
115	7	33-34
116	7	33-34
117	7	33-34
118	7	33-34
119	7	33-34
120	7	33-34
121	7	33-34
122	7	33-34
Combinations with a-m/f-m chassis		
801, 802	7	34
Mars TV	7	34-35
630-K3B	7	34-35
Mattison TV	7	35
630-6A	7	35
630-6B	7	35
Meck	3	12-16
	7	35-37
9018	3	12-14
9022	3	12
9024	3	12
9026	7	35-36
9032	7	35-36
9033	7	35-36
9034	7	35-36
9043	7	36
9043 with uhf tuner	7	37
9044	7	36
9044 with uhf tuner	7	37
9045	7	36
9045 with uhf tuner	7	37
9047	7	36
9048	7	36
9049	7	36
9050	7	36
9051	7	36
9053	7	36
9054	7	36
9055	7	36
Chassis with 1X2 rectifier	3	14
Chassis with TT-10006 tuner	3	14-15
All chassis	3	15-16
Montgomery		
Ward	3	20-32
	7	37-43
05RB-3034A	3	20
05GCB-3019A	3	20-22
05GSE-3020A	3	22-25
05WG-series	3	26
15BR-3035A	3	20, 26-27
15BR-3048A	3	20
15BR-3053B	3	20, 27
15BR-3053A	3	20, 27

Mfr. Model or Chassis	Vol.	Page
16K1/63-3019	3	20-22, 27-28
25BR-3058	7	37-38
25BR-3061	7	37-38
25BR-3067	7	37-38
25BR-3068	7	37-38
25BR-3069	7	37-38
25WG-series	3	28-29
25WG-series	7	38-40
25WG-3071	7	39
25WG-3071D	7	39
25WG-3072	7	39
25WG-3073	7	39
25WG-3073D	7	39
25WG-3075	7	39
25WG-3075A	7	29
25WG-3075B	3	29
25WG-3077	7	39
25WG-3077A	3	29
25WG-3077B	3	29
25WG-3079	3	29
25WG-3079	7	39
35BR-3158	7	37-38
35BR-3158A	7	41-42
35BR-3167	7	37-38
35BR-3167A	7	41-42
35BR-3168	7	37-38
35BR-3168A	7	41-42
35BR-3169	7	37-38
35BR-3169A	7	41-42
35WG-series	7	38-39
35WG-3060	7	40-41
35WG-3060B	7	39
35WG-3066	7	40-41
35WG-3070	7	40-41
35WG-3070B	7	39
35WG-3071	7	40-41
35WK-3072	7	40-41
35WG-3073	7	40-41
35WG-3075	7	40-41
35WG-3077	7	40-41
35WG-3079	7	40-41
35WG-3160	7	40-41
35WG-3170	7	40
35WG-3177	7	40
35WG-3180	7	40
35WG-3180	7	40
35WG-3190	7	40
84HA-3010A	3	29-31
84HA-3010B	3	29-31
84HA-3010C	3	29-31
94GCB-3023A	3	20-22, 27-28, 31-32
94GCB-3023B	3	20-22, 27-28, 31-32
94GBC-3023C	3	20-22, 27-28
94WG-series	3	32
Models with 6BQ7 tube in tuner	7	42-43
Motorola	3	32-43
	7	43-59
TS-14	3	32-33
TS-23	3	32-33

Mfr. Model or Chassis	Vol.	Page
TS-52	3	32-33
TS-53	3	32-33
TS-60	3	32-33
TS-67	3	32-33
TS-74	3	32-33
TS-89	3	34-35
TS-95	3	34-35
TS-101	3	35-36
TS-114A	3	36-37
TS-118A	3	35-37
TS-118B	3	35-37
TS-119A	3	34-38
TS-119B	3	34-38
TS-119C	3	34-38
TS-172A	3	36-37
TS-174A	3	35-37
TS-174B	3	35-37
TS-174C	3	35-37
TS-216	3	38
TS-275	3	38
TS-292 series	7	43-45
TS-324	3	38-40
TS-325	3	38-40
TS-326	3	38-40
TS-351	3	38-40
TS-402	7	45-51
TS-410 series	7	43, 51
TS-410	7	51-52
TS-418	7	45-49
TS-502 series	7	49-52
TS-502	7	45-50, 52-53
TS-505series	7	49-52
TS-507 series	7	49-52
TS-518 series	7	52
TS-518	7	45-50
TS-524 sehics	7	49-52
TS-524	7	50, 52
TS-525 series	7	53-54
TS-525	7	45-49
TS-528	7	45-49
TS-531	7	45-49
TS-602 series	7	54-55
TS602	7	55
TS-602 with 24; 27-tube	7	55
TS-603	7	45-49
TS-609	7	45-49
Chassis with TC-101 uhf converter	7	56-57
Split-sound chassis with uhf converted	7	55-56
All intercarrier chassis	3	40-42
All chassis	3	42-43
	7	57-59
Muntz	3	43-52
	7	59-61

VIII

Mfr. Model or Chassis	Vol.	Page	Mfr. Model or Chassis	Vol.	Page
16A series	3	43-44	2105	3	65-66
17A series	3	43-45	2105A	3	65-66
17A2	3	45-46	2111	3	65-66
17A3	3	45-46	2112	3	65-66
17A3A	3	45-46	2113	3	65-66
17A4	3	45-46	2114	3	65-66
17A5	3	45-46	2115	7	71-72
17A6	3	45-46	2116	7	71-72
17A7	3	45-46	2117	7	71-72
17B1	3	46-48	2118	7	71-72
17B2	3	46-48	2202-TV	3	65-66
	7	59	2204-TV	3	65-66
17B3	3	46-48	2301	3	65-68
17B4	3	46-48	2302	3	65-68
17B5	3	46-48	2311	3	65-68
17B6	3	46-48	2421	7	72-74
	7	59	2422	7	72-74
17B8	7	59-61	2423	7	72-74
M169	3	48-49	2721	7	74-75
Chassis with TO-0031 transformer	3	49-50	2722	7	74-75
Chassis below serial No. 22000	3	50	2723	7	74-75
All chassis with FU-002-1 fuse	3	49	2724	7	74-75
All chassis	3	50-52	2740	7	75-77
	7	61	2801-TV	3	65-66
Pacific Mercury	3	63-65	2801A-TV	3	65-66
	7	61-69	2803	3	65-68
150 series	3	63	2811	3	65-66
	7	61-66	2840	7	75-76
150-41	7	66	2921	7	74
150-42	7	66	2922	7	74-75
200 series	7	61-62, 66	2940	7	75
201 series	7	66	3040	7	75-76
Combinations with 155, 160 radio tuners	7	67	Chassis 2740, 2840, 3040, with vhf/uhf tuner 10535C	7	76
Chassis with cascade tuner	7	67, 69	Chassis with uhf	7	78
All 17- and 20-inch models	3	64	All early 22-tube chassis	3	68
All models with electrostatic focus picture tubes	3	64	Philco	3	68-113
	7	69		7	78-91
All models	3	65	Deflection chassis D-181	7	78-79
Packard-Bell	3	65-68	Deflection chassis D-191	7	78-79
	7	69-78	Deflection chassis D-194	7	78-79
T-1	3	69-71	Deflection chassis D-197	7	79
T-10	7	69-71	Deflection chassis D-201	7	79-80
T20	7	70	Deflection chassis D-204	7	78-80
1840	7	70	Deflection chassis D208	7	80-83
2040	7	70-71	Deflection chassis H-1	7	82-83
2101	3	65-66	Deflection chassis H-4	7	82-83
2102	3	65-66	Deflection chassis J-2	7	79, 83-84

Mfr. Model or Chassis	Vol.	Page
Deflection chassis J-4	7	84
Deflection chassis J-5	7	79, 83
G-1	3	89
G-1A	3	89
Power chassis A1	3	91-92
Power chassis AP1	3	91-92
Power chassis C1	3	91-99
Power chassis C2	3	91-99
Power chassis C3	3	91-99
Power chassis CP1	3	91-99
Power chassis D1	3	97-100
Power chassis D1A	3	97-100
Power chassis D4	3	97-100
Power chassis D4A	3	97-100
Power chassis F2	3	95-101
Power chassis FR2	3	95-101
R-f chassis R-181	7	84-85
R-f chassis R-191	7	85-87
R-f chassis R-192	7	85
R-f chassis R-194	7	85-87
R-f chassis R-204	7	87
R-f chassis R-207	7	86
R-f chassis 3P1	3	101-102
R-f chassis 3R2	3	101-102
R-f chassis 32	3	101
R-f chassis 33	3	95-99, 101
R-f chassis 34	3	95-99, 101
R-f chassis 35	3	95-99, 101
R-f chassis 37	3	95-99
R-f chassis 38	3	95-99
R-f chassis 41	3	89-90, 97-99, 102
R-f chassis 44	3	89-90, 97-99, 102
R-f chassis 71	3	89-91
R-f chassis 71A	3	89-91
R-f chassis 81	7	89-90
R-f chassis 84	7	89-91
R-f chassis 94	7	91
RT-10	3	82-83
TV-70 series	3	83
TV-80 series	3	83-85, 86-88
TV-90 series	3	87-89
TV-84	3	83-85, 88
TV-94	3	87
TV 84	3	88-89
TV-94	3	88-89
48-700	3	68-71
48-1000	3	68-71
48-1001	3	68-71
48-1050	3	68-71

Mfr. Model or Chassis	Vol.	Page
48-2500	3	68-71
49-models with turret tuner	3	68-71
50-702	3	71
50-1403	3	71-72
50-1630	3	71-72
50-T series	3	72
50-T1104	3	72-73
50-T1105	3	72-73
50-T1106	3	72-73
50-T1400 series	3	73-74
50-T1400	3	72, 74-76
50-T1401	3	72, 74-76
50-T1402	3	72, 74-76
50-T1403	3	72, 76
50-T1404	3	72, 76
50-T1405	3	72, 76
50-T1406	3	72, 76
50-T1430	3	72 74-75
50-T1432	3	72
50-T1483	3	76
50-T1630	3	76, 78
50-T1600	3	77
50-T1632	3	77
50-T1633	3	77
51-T1800 series	3	78-79
51-PT1200 series	3	78-79
51-PT1200	3	79
51-PT1207 series	3	79
1600 series	3	81
1800 series	3	81
2100 series	3	81
2500 series	3	81
7008	3	81-82
7070	3	81-82
7170	3	81-82
Models with 7F8 mixer oscillator	3	102
Models with 76-5411 tuner	3	102-104
Models with Colorado tuner	3	104-107
1950 models with built-in antenna	3	108
1951 models	3	108-110
1952 models	3	110
All 10-, 12-, 16-inch models	3	107
All models	3	110-113
Philharmonic	4	1-3
	7	92
C6161	4	1-2
T616	4	1-2
20C2B	4	1-3
20CD2B	4	1-3
20T2B	4	1-3
61	4	1
111	4	1-3
112	4	1-3
616	4	1
724	4	1-3

Mfr. Model or Chassis	Vol.	Page
800 series	7	92
800 series with cas-code tuner	7	92
820	4	1-3
900 series	7	92
900 series with cas-code tuner	7	92
920	4	1-3
924	4	1-3
1116	4	1-2
5221	4	1-3
5816	4	1-2
8120	4	1-3
8820	4	1-2
9120	4	1-3
9820	4	1-2
Radio Craftsman	7	92-98
C-210	7	96-97
C-210P	7	97

Mfr. Model or Chassis	Vol.	Page
RC-100	7	92-94
RC-100A	7	92-94
RC-101	7	92-96
RC-200	7	92-96
RC-201	7	92-96
RC-202	7	92-96
Models with 19S 012, 19S012A h-v transformer	7	97-98
Models with cas-code tuners	7	98
Raytheon	7	98-103
17T1	7	98-100
17T2	7	98-100
21T1	7	98-100
21T2	7	98-100
21T3	7	100-101
21T8	7	101-102
21T11	7	101-102
24T3	7	102-103



GENERAL ELECTRIC Models
17C125, 20C107,
21C201, 202, 204,
206, 208, 210, 214,
21T1, 3, 6

Replacement of crystal diode.

For replacement purposes, special diodes (cat. No. RED-001) are being diodes (cat. No. RED-001) are ceiver operation, it is not recommended that any other type of diode be used for replacement purposes.

GENERAL ELECTRIC Models
17C125, 20C107,
21C201, 202, 204,
206, 208, 210, 214,
21T1, 3, 6

Replacement of filament transformer.

When replacing the filament transformer, *T401*, in 4th production models only, be sure to measure the voltage at pin 3 of *V106* (3rd video i-f). This voltage should read approximately 12 volts. If zero or near zero volts are measured at this point, the *primary* leads should be reversed.

GENERAL ELECTRIC Models
17C125, 20C107,
21C201, 202, 204,
206, 208, 210, 214,
21T1, 3, 6

Checking noise inverter.

A simple oscilloscope check may be performed which will display the

operation of the noise inverter. The procedure is based upon noise pulse inversion in the absence of signal.

1. Turn on receiver. Set channel selector switch to an unoccupied channel.

2. Connect oscilloscope to test point *IX* (junction of *C302*, .01- μ f capacitor connected to pin 1 plate of noise inverter, and *C303*, 470- μ f coupling capacitor connected between *C302* and the pin 2 grid of the clipper).

3. Bias off the noise inverter (*V113B*) by connecting a 100,000-ohm resistor between its pin 3 and +250 volts.

4. Supply a moderate-amplitude noise signal to the antenna input terminals. A suitable noise source would be an electric shaver or similar spark-type noise generator.

5. Observe positive polarity of noise pulses on oscilloscope. Removal of the temporarily added 100,000-ohm resistor should cause the noise signal to reverse itself and hence become negative in polarity.

GENERAL ELECTRIC Models
17C125, 20C107,
21C201, 202, 204,
206, 208, 210, 214,
21T1, 3, 6

Checking Global filament resistor.

Those tubes having 300-ma heaters are connected in a series circuit containing a global resistor *R402*. This resistor is designed so that its cold resistance is in the order of 200 or 300 ohms, and when at operating temperature approximately 31 ohms.

A cold resistance check is almost valueless since the resistance reading may vary widely between resistors.

The surest method of checking *R402* is to read the voltage drop across it. This should be in the vicinity of 10 volts with the receiver operating on a 117-volt a-c line.

GENERAL ELECTRIC Models
17C125, 20C107,
21C201, 202, 204,
206, 208, 210, 214,
21T1, 3, 6

Replacement of Components in detector can assembly.

In 1st and 2nd production chassis, the detector can assembly is constructed so that the diode detector is located under the removable "hat."

In 3rd and 4th production receivers, the detector assembly is changed. To change the diode or any other component within this assembly, it is merely necessary to remove the two self-tapping screws at the base of the assembly. The entire assembly may then be pulled off of the mounting plate. The shield can then be removed from the assembly by compressing the two spring tabs on the top tuning core securing clip.

GENERAL ELECTRIC Models
17C125, 20C107,
21C201, 202, 204,
206, 208, 210, 214,
21T1, 3, 6

Improvement in picture quality.

The diode load resistor, *R162*, was changed in later production from 3,900 ohms to 3,000 ohms for im-

proved picture quality. For identification, these receivers were rubber-stamped on the back apron of the chassis with No. 420.

GENERAL ELECTRIC Models
17C125, 20C107,
21C201, 202, 204,
206, 208, 210, 214,
21T1, 3, 6

Replacement of horizontal output transformer and yoke.

In 3rd and 4th production models, the horizontal output transformer and yoke were changed. Receivers using these revised sweep components bear a label on the high-voltage compartment rear door which indicates the catalog numbers of the horizontal output transformer and yoke contained therein. Models 17C125 and 20C107 use horizontal output transformer RTO-130, 21-series models use RTO-129. The yoke to be used with either of these transformers is RLD-050. These components should not be used in those receivers which used the early-type transformer and yoke, unless a late transformer and a late yoke are simultaneously installed. The receivers using these late-type sweep components are rubber-stamped with No. 430.

GENERAL ELECTRIC Models
17C127, 17T15,
17T17, 21C114, 115,
116, 117, 119, 120, 121,
21T10, 11, 12, 14, 15, 19

Improved interlace and vertical control range (see Fig. 1)

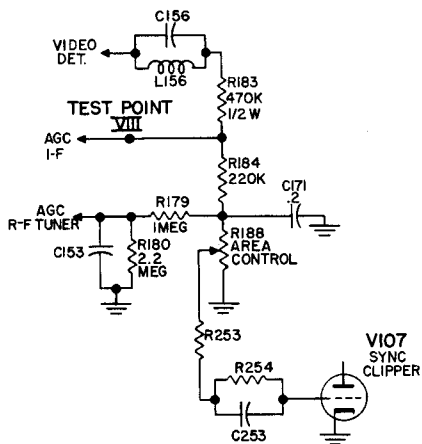

AGC CIRCUIT DIAGRAM

Fig. 2 — General Electric

The agc circuit in the late production of the "F" series receivers has been changed as follows and as shown in the attached partial schematic.

1. *C173*, .05- μ f capacitor, is removed.
2. *R166*, 68k ohms, is changed to *R183*, 470k, $\frac{1}{2}$ w, part No. URD-113.
3. *R184*, 220k ohms, part No. URD-105, is added.

As a result of this change, the rear Area Control covers a wider range, permitting slightly increased sensitivity for fringe reception and better picture stability in the very strong signal areas.

GENERAL ELECTRIC Models
17T10, 17T11,
17T12, 21T2

Improving vertical linearity.

To improve the vertical linearity, the vertical output tube was

changed in later production 'from 25L6GT to 25W6GT. These tubes are interchangeable and no change in tube socket wiring is necessary.

GENERAL ELECTRIC Models
17T10, 17T11,
17T12

Reducing height changes at different brightness settings.

To reduce height changes at different settings of the brightness control, *R276*, the resistor in the cathode of the picture tube was changed in later production from *R289*, 150,000 ohms (URD-101) to *R277*, 220,000 ohms (URD-105).

GENERAL ELECTRIC Models
17T10, 17T11,
17T12

Eliminating compression at top of picture.

To eliminate compression at the top of the picture, the resistor across the vertical output transformer, *T302*, was changed in later production from *R330*, 82,000 ohms (URD-095) to *R374*, 180,000 ohms (URD-103).

GENERAL ELECTRIC Models
17T10, 17T11,
17T12

Improving horizontal sync stability.

To improve horizontal sync stability under various conditions of signal strength levels, the feedback resistor connected from the grid of the horizontal oscillator (*V13B*) to the discriminator (*V12*) plate was changed in later production from *R279*, 180,000 ohms (URD-103) to *R390*, 330,000 ohms (URD-109).

GENERAL ELECTRIC Models
17T10, 21T2,
with uhf tuner

Weak and unstable vertical sync.

When the UHF-103 tuner is installed in a metal cabinet type receiver, there is a tendency for the cabinet to induce horizontal sync pulses into the vertical system. The condition is recognized by the fact that the vertical sync is weak and unstable.

To eliminate this trouble, connect a .01- μ f, 600-v molded paper capacitor between the front control apron and chassis.

A convenient location for this capacitor is on the right-hand side of the chassis looking at the front. Connect one lead of the capacitor to the center ground lug of the existing terminal board and the other lead to a soldering lug to be mounted under one of the screws fastening the front chassis mounting foot.

GENERAL ELECTRIC Models
20C105, 20C106,
20T2, 21C200,
21T4, 21T5

**Checking voltage sensitive
(Globar) resistor.**

The resistor R832 on the screen of the horizontal output tube, V14, is a voltage sensitive type. When the resistor is measured with an ohmmeter, its resistance may be a few megohms. However, this reading is meaningless because as soon as a voltage is applied across the resistance, its resistance value decreases instantly. The change of resistance is not brought about by heating but is due to an applied voltage.

Because of the negative resistance characteristic, it is not easy to determine whether a resistor is defective. Its resistance under operating conditions may be computed by measuring its voltage drop and then applying Ohm's law to determine the resistance value. The voltage drop across the resistor R382 under normal operating conditions is 140 volts.

GENERAL ELECTRIC Models
20C105, 20C106,
20T2, 21C200

Replacement of video detector.

In some video detector assemblies, a special high efficiency diode, marked with a red dot is used. To maintain the same Q of the circuit and to obtain proper bandwidth, a resistor of 12,000 ohms is connected across the diode. In replacing this diode with the normal type do not use this resistor. In case of doubt, check for proper bandwidth.

On some assemblies, the rectifier symbol is stamped on the top plate to indicate polarity of terminals. When replacing the diode, check to see that both the diode cathode and plate markings are in the same direction.

GENERAL ELECTRIC Models
20C105, 20C106,
20T2, 21C200

**Reduction of hum and picture
slide.**

Excessive hum modulation of the horizontal sweep was reduced in later production by the following changes:

1. Addition of another 80- μ f capacitor, RCE-112, across capacitor C353 in the filter section.

2. Lead dress changes: Red horizontal blanking lead going to the screen of the picture tube enters the chassis through the slot between the horizontal drive control and horizontal hold and goes directly to its original connection on the terminal board instead of entering the chassis with other leads through a rubber grommet.

The blue lead running from the plate (pin 5) of sync amplifier tube, *V11*, to the junction of *R352*, (22k ohms), *R353* (470k ohms) and *C353* (470 μmf) was placed directly over the resistor *R320* (100,000 ohms) adjacent to *R352* by taking up slack in the lead.

GENERAL ELECTRIC Models
20C150, 20C151,
24C101

Checking agc circuit (see Fig. 3).

The agc action may be seriously impaired or fail completely if the

linearity, drive and/or width controls are maladjusted. The effect of these controls upon the agc action vary in the order listed above; linearity having the greatest effect.

A rapid check which automatically tests both the agc keyer tube (*V117*) and its associated components may be made as follows:

1. Short pins 1 and 2 of keyer tube, *V117*.

2. With a vtvm, the voltage at the agc test point No. 8 should read at least -28 volts and in some receivers as high as -40 volts.

3. A further check of the voltages throughout the agc keyer circuit may be made by checking the voltages shown in the accompanying diagram. First adjust the receiver for normal picture. Then, with an oscilloscope, adjust the contrast control for a 12-volt peak-to-peak signal as shown at pin 1, *V117*. The keying pulse on the

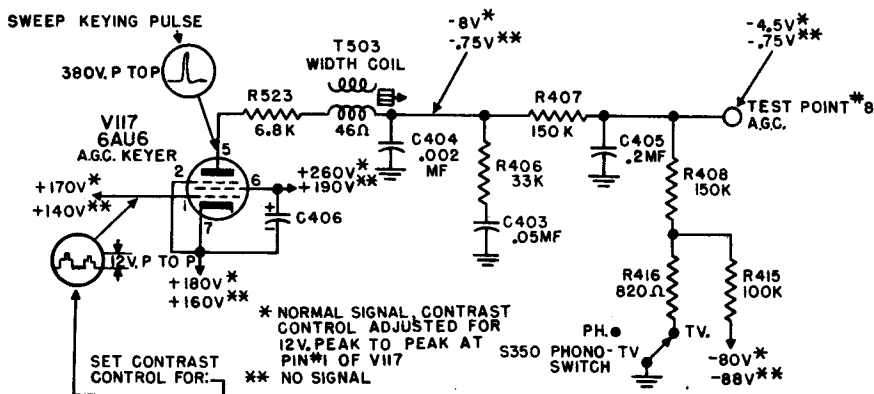

Simplified Schematic of AGC

Fig. 3 — General Electric

plate of *V117* will vary in amplitude according to the adjustment of the width control and the horizontal linearity control. These must be properly adjusted before making the age circuit measurements.

GENERAL ELECTRIC Models
20C150, 20C151,
24C101

Checking horizontal afc circuit.

With an ohmmeter, set the horizontal hold control to the center of its resistance range (approximately 50k ohms). Tune in a good, normal picture and once adjusted leave all controls set except as noted below. Connect a vtvm to the grid (pin 7) of the reactance control tube (*V119B*). Adjust the core of the horizontal oscillator coil, *L500*, for zero volts. The control range may now be checked by noting the following reactance tube grid voltages:

At center	0.0 v
Full clockwise	+1.5 v
Full counterclockwise	-3.5 v

The picture should remain in sync during test. These voltages are the average expected voltages which may vary slightly in different receivers. Failure to remain in sync or failure to produce the above voltages within close limits will necessitate checking the circuits of tubes *V118* and/or *V119*, assuming that the vertical sync is functioning properly.

GENERAL ELECTRIC Models
21C201, 202,
204, 206, 208, 210,
214, 21T1, 3, 6

Preventing arc-over in h-v compartment.

Under humid conditions, poor lead or component dress on the high-voltage rectifier bracket may cause arc-over. It may occur between the plate cap of input rectifier (*V121*) and the solder lug which is fastened to the center of the socket of the middle rectifier (*V122*). To remedy this condition, dress tube *V121* away from the middle rectifier tube (*V122*). Also bend the above-mentioned solder lug up and away from the plate cap of rectifier tube *V121*.

GENERAL ELECTRIC Models
21C225, 226,
227, 228, 229, 230,
231, 232, 233, 21T20, 21T21

Improved horizontal linearity.

The linearity of the horizontal sweep was improved by incorporating a new circuit which used the following new items:

1. RLD-056 horizontal linearity coil.
2. RLD-048 horizontal width coil.
3. RTO-146 horizontal output transformer.

These items should not be used as replacements in earlier production chassis.

Chassis incorporating this production change bear a rubber stamp "548" and in most cases also bear a label on the high-voltage cage which calls attention to the electrical items listed above.

GENERAL ELECTRIC Models
21C225, 226,
227, 228, 229, 230,
231, 232, 233, 21T20, 21T21

Reducing i-f interference.

To assist in the reduction of i-f interference, chassis bottom plate,

RHS-119 and adjacent channel trap shield can, RHS-112 was added during later production runs.

GENERAL ELECTRIC Models
21T4, 21T5

Protection of horizontal output tube.

In order to reduce the danger of overdriving the horizontal output tube, 25BQ6, the horizontal drive potentiometer was changed in later production from a value of 25,000 ohms to 5,000 ohms.

GENERAL ELECTRIC Models
21T4, 21T5

Improving vertical sync.

In order to increase vertical sync tightness, the capacitor C305, 1,000- $\mu\mu\text{f}$ unit in the grid circuit of the vertical sweep tube, V9, 12SN7 was changed in later production to C316, 1,200 $\mu\mu\text{f}$. Some receivers had a 220- $\mu\mu\text{f}$ mica capacitor added to the 1,000- $\mu\mu\text{f}$ capacitor.

GENERAL ELECTRIC Models
21T4, 21T5

Improvement of vertical sync stability.

In late production receivers, the stability of the vertical sync was improved by disconnecting the age to the 3rd i-f tube, V6, 6CB6. The grid was connected directly to ground.

GENERAL ELECTRIC Models
21T10, 21T11

Adjustment of focus.

Late production models 21T10 and 21T11 use the electrostatic picture tube type 21FP4A. The receiver

leaves the factory with the focus lead connected to ground. If the focus requires adjustment, connect the focus lead to B+ or B+ boost instead.

GENERAL ELECTRIC Model
25C101

Replacement of horizontal output transformer.

A late production run of part No. RTO-104 horizontal sweep and high voltage transformers was improved to increase the temperature rise limits of these units. The late transformers bear the code number 31 and the replacement parts stock catalogue RTO-104. These transformers may also be identified by the lower resistance reading of 28.5 ohms for the primary (terminals 1 and 7) in contrast to 38 ohms for the early production units.

When using this transformer as a replacement for the early production transformer, it is necessary to remove the 300-ohm wirewound tapped resistor strip R538, R539 in the cathode circuit of the horizontal sweep output tubes V124 and V126, and replace it with a new resistor strip, RRW-093, 450 ohms tapped at 50 ohms.

GENERAL ELECTRIC Model
25C101

Greater audio sensitivity and better sound limiting.

L220, sound detector coupling choke, is 1.4 microhenries for later production receivers. Coincident with this choke change from the 2.2-microhenry value for early receivers, the sound takeoff circuit coil L212 is aligned to a new amplitude ratio of

7 to 1 between the picture and sound markers on the sound detector output response curve. These changes contribute to greater audio sensitivity and better sound i-f limiting.



HALLICRAFTERS Chassis
A1100D, F1100D

Improving horizontal oscillator stability.

To improve horizontal oscillator stability, any one or all of the following changes are made. Many of the following are already included in later production.

1. *R173* (150,000-ohm resistor connected to pin 4 of the horizontal oscillator) is changed from a 10%, 1/2-watt to a 5%, 1-watt resistor.

2. *C147* (330- μ f capacitor also connected to pin 4 of the horizontal oscillator) is changed from a plain mica to a 10% silver mica capacitor.

3. *R177* (330,000-ohm resistor connected to terminal *D* of the horizontal oscillator transformer) is changed from a 10%, 1/2-watt to a 5%, 1-watt resistor.

4. *C179* (68- μ f capacitor connected to the other end of *R177*) is deleted as required to increase the range of the horizontal range adjustment.

5. The cold end of *C146* (.05- μ f, 600-v capacitor in the cathode circuit of the horizontal oscillator) is connected to the cathode (pin 3) of the horizontal oscillator (*V115*) instead of ground.

Note: When replacing *R173*, *R177* or *C147*, use the close tolerance parts

which are the ones specified in the service notes.

HALLICRAFTERS Chassis
A1100D, F1100D

Improving interlace.

To improve interlace, a shield is placed around the sync clipper and vertical oscillator tube *V107*. This shield will not be found on early chassis. On some chassis, good interlace was obtained with or without this shield.

HALLICRAFTERS Chassis
A1100D, F1100D

Increasing range of vertical hold control.

To increase the range of the vertical hold control, the 820,000-ohm, 1/2-watt resistor (*R191*) on the high side of the control is changed to 1.2 megohms, 1/2-watt and given a schematic symbol of *R139*. This change is already included early in production and consequently few chassis are in the field with *R191*, the 820,000-ohm resistor in use.

HALLICRAFTERS Chassis
A1100D, F1100D

Improving retrace blanking.

To improve retrace blanking, the 47,000-ohm, 1/2-watt resistor (*R138*) between one side of the brightness control and ground is changed to *R220* with a value of 10,000 ohms, 1/2-watt. This change is already made in Run-2 production of the above chassis.

HALLICRAFTERS

Chassis
1100D, G1100D

Improving sound sensitivity.

To improve sound sensitivity, the sound take-off point is changed from the plate (pin 5) of the video amplifier to the junction of *L114* (connected to pin 2 of the video detector) and *L101*. At the same time the 2.2- μmf coupling capacitor (*C112*) is changed to 4.7 μmf and given a schematic symbol of *C184*.

The plate and screen voltage for the audio i-f amplifier is increased by replacing *R148* (22,000 ohms, 1/2-watt) with *R222* (4,700 ohms, 1/2-watt). In the sound detector circuit, the de-emphasis capacitor *C130* (1,000- μmf ceramic) is replaced by *C186* (2,000- μmf ceramic).

Note: These changes are already included in later production of the above chassis.

HALLICRAFTERS

Chassis
1100D, G1100D

Preventing top picture foldover and improving vertical linearity.

To prevent top picture foldover and improve vertical linearity:

1. The 2.2-meg grid-leak resistor (*R213*) for the vertical amplifier (*V108*) is changed to a 1-meg, 1-watt resistor (*R145*).

2. A 3.3-meg, 1/2-watt resistor (*R221*) is added between ground and the junction of *R143* (1 megohm, 1 watt) and the height control *R146*.

3. The vertical output transformer *T114* (part No. 55C189 with d-c resistance of 1,600 ohms) is replaced

by *T116* (part No. 55C199 with d-c resistance of 1,400 ohms).

4. The 10%, 12,000-ohm, 1/2-watt resistor (*R214*), connected to the high side of the vertical linearity control, is replaced by a 5%, 10,000-ohm, 1/2-watt resistor, (*R223*).

Note: These changes are already made in later production of the above chassis.

HALLICRAFTERS

Chassis
1200D-series

Improved sync in fringe areas.

To improve vertical and horizontal sync particularly under extreme fringe area receiving conditions, the following changes are found in later production chassis.

1. *R124*, 10,000-ohm, 1/2-watt resistor in coupling circuit to sync clipper is replaced by a 22,000-ohm, 1/2-watt resistor (*R195*).

2. *R125*, 470,000-ohm, 1/2-watt resistor also used in the above coupling circuit, is replaced by 220,000-ohm, 1/2-watt resistor (*R196*).

3. *R183*, 47,000-ohm, 1/2-watt resistor in the coupling circuit between the sync clipper and vertical oscillator, is replaced by 33,000-ohm, 1/2-watt resistor (*R197*).

4. *C124*, 22- μmf , 500-v ceramic tubular capacitor connected to pin 1 grid of sync clipper, is replaced by a 47- μmf , 500-v ceramic tubular capacitor (*C172*).

5. A 1,000- μmf , 500-v ceramic disc capacitor (*C171*) is added between pin 5 and ground of the 12AX4 damper tube *V110*.

HALLICRAFTERS

Chassis
1200D-series

Replacing pentode tuner with cascode tuner.

To use a 1C1376 cascode tuner in place of the 1C1345 pentode tuner, the following changes are made:

1. The 1C1345 pentode tuner is removed and replaced by the 1C1376 cascode tuner. These two tuners do not have the same terminal connections. Refer to schematic diagram in service notes for connections. The 1C1376 cascode tuner may be used only with chassis which have a heater transformer.

2. A wire to supply 260 volts dc is added between tuner terminal 4 of the cascode tuner and the junction of *R120* (33,000-ohm, 1-watt video amplifier screen resistor) and the 260-volt B supply.

To use a 1E1380 cascode tuner in place of the 1C1345 pentode tuner, the following changes are made:

1. The 1C1345 pentode tuner is removed and replaced by the 1C1380 cascode tuner. The 1E1380 tuner does not have terminal lugs on the back. The wire leads from this tuner must be connected to the correct points in the chassis as shown in the schematic diagram in the service notes. The 1E1380 tuner also requires a supply voltage of approximately 250 volts, and may be used only with a 3 3/4-inch deep chassis which have a heater transformer.

2. Resistor *R101* (100,000 ohms, 1/2-watt) in the agc bus is not required.

HALLICRAFTERS

Chassis
1200D-series

Addition of h-v filter capacitor.

Whenever the picture tube that is used has a metal cone which eliminates the high-voltage filter capacitor built into tubes with an outer Aquadag coating, *C166* (500- μ mf, 20,000 volts) is required between pin 7 and ground of the 1B3GT high-voltage rectifier. Resistor *R210* (1 megohm, 1 watt) is also added in series with the anode lead.

HALLICRAFTERS

Chassis
1200D-series

Using a larger picture tube.

In order to change from a 17-inch to a 20- or 21-inch picture tube, the following electrical modifications are made:

1. Add an 82k-ohm, 1/2-watt resistor (*R178*) between the high side of the horizontal hold control and the pin 1 grid of the horizontal oscillator.

2. Add a 220k-ohm, 1/2-watt resistor (*R179*) between the pin 2 plate of the horizontal oscillator and this tube's decoupling resistor.

3. Add a .1- μ f, 600-volt paper capacitor (*C162*) between the junction of *R179* and *R156*, the 120k-ohm plate decoupling resistor.

4. Replace *R156* by a 180k-ohm, 1/2-watt resistor (*R194*). The bottom end of this resistor is returned to terminal 1 of *T109* (horizontal output transformer). Note: *T109* is the new transformer described below.

5. *R157*, 4700-ohm, 1/2-watt peaking resistor in the pin 2 plate circuit of the horizontal oscillator, is re-

placed by an 8,200-ohm, $\frac{1}{2}$ -watt resistor (*R180*).

6. *C145*, 470- μmf sweep forming capacitor in series with a peaking resistor, is replaced by a 390- μmf silver mica capacitor (*C163*).

7. *C146*, 5000- μmf disc ceramic capacitor used for horizontal output stage grid coupling, is changed to a 560- μmf silver mica unit (*C164*).

8. Horizontal output stage grid resistor *R158* (330k ohms) is replaced by a 390-ohm, $\frac{1}{2}$ -watt resistor (*R181*).

9. A .047- μf , 400-volt paper capacitor (*C165*) is added as the screen bypass for the horizontal output stage screen.

10. A 10,000-ohm, 2-watt resistor (*R182*) is added as the screen resistor for the horizontal output stage.

11. The horizontal output transformer part No. 55D193 (*T106*) is replaced by horizontal output transformer part No. 55D197 (*T109*).

12. The two 150k-ohm, 1-watt resistors (*R151*, *R152*), which are series-connected in the servo feedback loop from the horizontal output to the afc tube, are replaced by a 33,000-ohm, 1-watt resistor (*R177*).

13. The 140- μf , 150-volt electrolytic capacitor (*C135*), used as the series capacitor in the doubler power supply is replaced by a 200- μf , 150-volt electrolytic capacitor (*C161*).

14. The audio voltage amplifier cathode resistor *R169* (1,500 ohms) is replaced by a 1,200-ohm, $\frac{1}{2}$ -watt unit (*R176*).

15. The loudspeaker with a field coil resistance of 85 ohms is replaced by a speaker with a field coil resistance of 61 ohms.



HOFFMAN

Chassis
171-series with
uhf strip

UHF split tuning (see Fig. 4).

Uhf strip conversion of the older television receivers using split sound i.f. (21.6 mc) sometimes results in a split tuning condition. Good video or good audio may be received but not both at the same setting of the fine tuner. This condition can be minimized by converting the audio i-f section to 4.5-mc intercarrier sound.

The modification is especially recommended for the above chassis which have been converted from the use of the Silver Circle tuner. Sound volume is improved and audio quality remains good.

Parts list for conversion to intercarrier sound are:

- 1 4.5-mc i-f transformer (part No. 5428)
- 1 Ratio detector (part No. 5429)
- 1 Audio take-off coil (part No. 5430)
- 1 68-k, $\frac{1}{2}$ -watt resistor
- 1 22-k, $\frac{1}{2}$ -watt resistor
- 1 250- μmf mica capacitor
- 1 10- μmf mica capacitor

HOFFMAN

Chassis 190,
191, 192

Preventing excessive loading on horizontal output transformer.

R719, the 100k-ohm, 1-watt resistor that is shunted across lugs 1

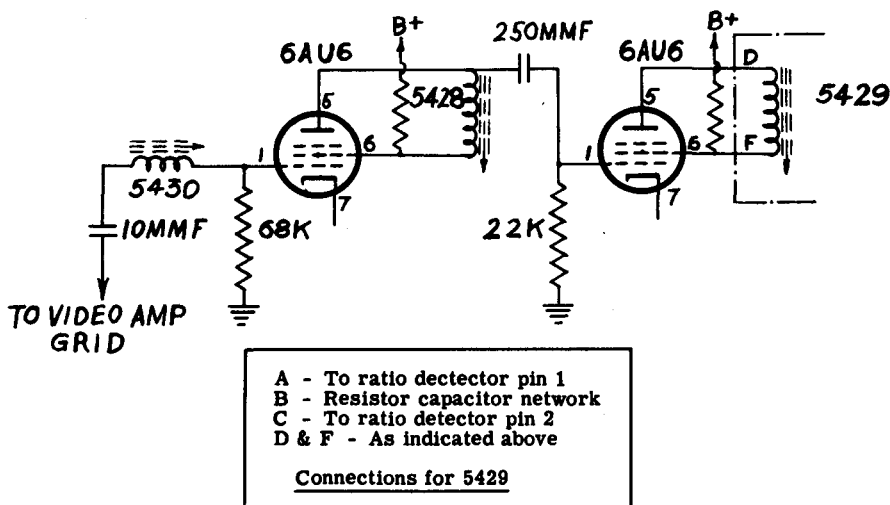

Fig. 4 — Hoffman

and 2 of L703 (horizontal yoke winding) is deleted from the above chassis. The change results in a slight increase in high voltage and horizontal width. It is suggested that the change be made on service call as preventative maintenance since should R719 decrease appreciably in value over a period of time, the result would be excessive loading on the horizontal output transformer, causing low horizontal sweep, low high voltage, and low agc keyer pulse. In some instances, the lowering in keyer pulse has been responsible for sync clipping because the agc bias became too low in a strong signal area.

HOFFMAN

Chassis
190-series

Addition of agc control (see Fig. 5).

An agc control has been incorporated in later production of the

above series receivers. The new control is located on the chassis rear apron next to the Horizontal Frequency knob. The figure shows the new agc circuit. A comparison of this circuit with the original schematic diagram will disclose that R402, the 47k-ohm resistor that forms a portion of the agc voltage divider, has been replaced by a 50k-ohm potentiometer connected as a rheostat and a 15k-ohm fixed resistor. This circuit arrangement places the position of the tap on the i-f agc voltage divider at the discretion of the serviceman. In order to maintain the crossover point of the r-f and i-f agc voltage where it was prior to the above change, it is necessary to increase R407, the 180k-ohm resistor, to 330k ohms in the delayed agc network.

When the agc control is turned fully clockwise, the greatest bias appears on the i-f agc bus and the lowest

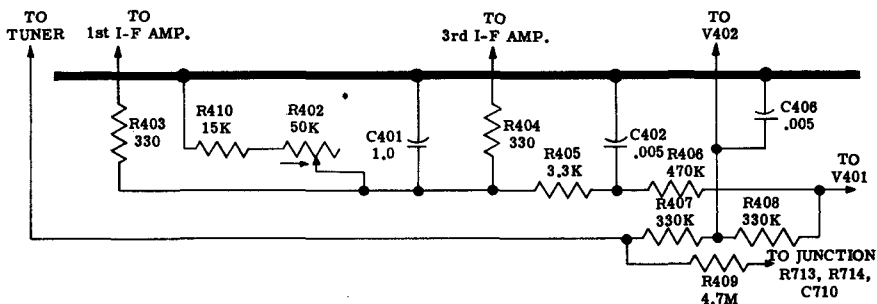

Fig. 5 — Hoffman

bias appears on the r-f agc bus for a given signal. When the control is turned fully counterclockwise, the situation is reversed; the i-f agc bias voltage is minimum and the r-f agc bias is maximum for a given signal. This source of high r-f bias is very useful when strong signals cause the video stages to overload, clipping the sync pulses.

In very strong signal areas, turn the agc control counterclockwise until loss of sync is eliminated. Do not turn more than necessary, though, because increased bias on the r-f amplifier with simultaneous decrease in i-f bias will lead to excessive noise in the picture after a certain point is reached. Conversely, in weaker signal areas, the control should be turned clockwise so that the r-f bias is reduced and the i-f bias is increased. This condition will improve the signal-to-noise ratio, minimizing snow in the picture. Again, take care not to turn the control too far or the i-f stages may be overdriven, resulting in sync clipping. The optimum point of adjustment of the agc control is

a function of signal strength. The serviceman should use the picture quality as his indicating device and adjust for optimum performance.

HOFFMAN

Chassis
196-series

Unstable sync in fringe areas.

Some of the chassis types given above have exhibited unstable sync in fringe areas. The solution to this problem is simple. Clip R308 from the chassis. R308 is the 1/2-watt, 1-meg composition resistor that is wired across pins 1 and 6 of the agc keyer tube socket. This socket is the front, left-hand socket when viewing the chassis from the bottom rear position.

This change has been put on a production basis on all of these receivers produced after serial No. J243241. As a preventative maintenance measure, it is recommended that this change be made on all earlier receivers of the types given when the chassis is being serviced for any reason.

HOFFMAN Chassis 196
Improved horizontal output transformer.

The No. 5160 horizontal output transformer is replaced by part No. 5160-5. The new transformer is an improved version of the original transformer. Changes made in the 5160-5 transformer provide for better insulation in the coils and improved impedance match between the transformer and the horizontal deflection coils. The physical appearance of both transformers is the same, except for deletion of terminal 5 on 5160-5. When substituting the new transformer, the connections for terminal 5 should be added to terminal 7. All other connections remain the same as on the original transformer.

HOFFMAN Chassis 200,
201, 202

Horizontal jitter in fringe areas.

Field reports have indicated that some receivers of the chassis types listed above have exhibited a horizontal jitter problem in fringe areas. Increasing the value of the capacitor connected between pin 4 of the horizontal multivibrator and ground will reduce the jitter so that it is negligible. Increase the value from 0.01 μ f to 0.05 μ f. A 20%, 400-v capacitor may be used. This capacitor is shown as C706 in the service notes.

HOFFMAN Chassis 200,
201

High-voltage breakdown and corona.

The following methods are used to reduce a tendency to breakdown or to produce corona.

1. The 1B3 filament winding should be moved as far from the h-v winding as possible.

2. The lead that goes from the 1B3 filament to the picture tube anode connection should be attached to pin 2 instead of pin 7 and all sharp points of solder on the socket lugs should be removed.

3. Bend all 1B3 tube socket lugs in toward center of socket.

4. Bend lug on electrolytic capacitor which is located under the 1B3 down as far as possible.

5. Remove all sharp points from flyback transformer lugs.

6. Spray 1B3 socket, transformer lugs, and top of damper tube socket with Krylon acrylic spray.

HOFFMAN Chassis 210,
211, 212, 213

Picture shift at maximum contrast.

Some of the receivers listed above have had a slight horizontal shift when maximum contrast was used. This condition can be remedied by increasing the value of R304, 47-ohm, 1/2-watt, 20% resistor (connected between the low side of the contrast control and ground) to a 150-ohm, 1/2-watt, 20% resistor. When this is done, a connection should be run from the top, *not ground*, of this 150-ohm resistor to the Fringe position of the Maximum Performing selector switch on the rear of the set, so that when in a Fringe position, maximum contrast can still be obtained.

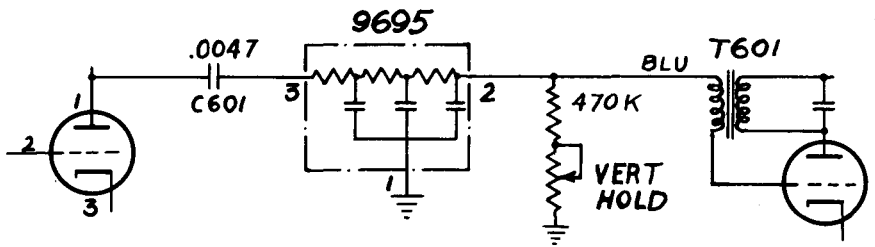

Fig. 6 — Hoffman

HOFFMAN Chassis 301,
302, 303,
306, 307, 308

Minimizing vertical jitter in fringe areas (see Fig. 6).

Some of the above chassis have been changed as follows: *R601*, *R602*, *C602*, and *C603* (vertical integrator components) have been deleted and part No. 9695 (intergrator network) substituted in its place. This change improves the sync stability of the circuit, and the change can also be used on the earlier chassis to minimize vertical jitter in fringe areas. The change should not be necessary except in areas of very weak signals.

HOFFMAN Chassis 301,
302, 303,
306, 307, 308

Sync improvement in noisy areas.

Sync stability of models using the above chassis can be improved in noisy signal areas by changing the value of one resistor in the grid circuit of the 1st sync separator. This resistor is *R502* on schematic diagrams for the above chassis and has a value of 4.7 meg, 1/2-watt. Replace

the 4.7-meg resistor with an 820k-ohm, 1/2-watt resistor, if noise pulses are causing unstable sync.

HOFFMAN Chassis 301,
302

Reducing intercarrier buzz.

In certain areas, a buzz problem has been encountered due to the modulation at the transmitter. This problem is cured by shifting the sound takeoff point from the plate circuit of the 6AH6 (*V301*) video amplifier to the junction of *C212* and *L205*. These components are the 10- μ mf capacitor and the 172- μ h peaking coil at the output of the video detector. Also, the values of *R212* (3.3k ohms) and *R213* (2.2k ohms) are interchanged. These resistors are connected between the output side of peaking coil *L205* mentioned above and *L206*, a 335- μ h peaking coil to ground.

HOFFMAN Chassis 301,
302

Increased horizontal and vertical stability.

In an area where there is a need for increased horizontal and vertical

stability, make the following changes: Add a .005- μ f 500-volt capacitor across the horizontal hold control. Change the value of C602 (vertical intergrator capacitor at input to vertical oscillator) from a .001- μ f to a .0047- μ f, 10%, 400-volt capacitor.

HOFFMAN Chassis 301,
302

Increased vertical hold range.

For increased vertical hold control range, add a 680k-ohm, 10%, 1/2-watt resistor between the center-tap and the ungrounded side of the vertical hold control. Also, add a 470k-ohm, 10%, 1/2-watt resistor from the ungrounded side of the vertical hold control to the blue lead of the blocking oscillator transformer.

HOFFMAN Chassis 301,
302

Preventing channel 7 feedback.

If feedback appears on channel 7, redress the speaker leads away from the antenna leadin.

HOFFMAN Chassis 303,
306

Changing i-f input capacitor when interchanging tuners.

The above chassis use two vhf-type tuners and two all-wave tuners as indicated in the parts list. Those chassis which use tuners 9786 and 9814 do not have C213 at the input to the video i-f section. The chassis using all-wave tuner 9838 have C213, a 68- μ f, 5% tolerance capacitor at the input to the i-f section of the re-

ceiver. Chassis using the vhf tuner 9839 have C213, an 82- μ f, 5% tolerance capacitor at the input to the i-f section.

It is important that capacitors of correct value and tolerance be installed when interchanging these vhf and all-wave tuners. These values are critical because of the effect of over-coupling or undercoupling between the tuner and the i-f section. It will not be possible to get the proper bandpass curve on the receiver if incorrect values are used. Capacitor tolerance must be no more than 5 percent.

HOFFMAN Chassis 306,
307, 308

Retrace line elimination.

Retrace line elimination may be improved in the above chassis by changing C608 (shunted across the vertical linearity control) from .0047 to .001- μ f. In some areas, picture information of limited contrast range will allow the retrace lines to be visible in the top inch or two of the picture. Changing C608 will take care of the problem.

HOFFMAN Chassis 306,
307, 308

Addition of agc control (see Fig. 7).

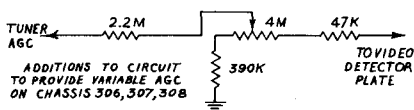

Fig. 7 — Hoffman

Refer to the sketch of the agc circuit for correct connections of new components added for the agc control. The control is mounted on the front of the chassis under the plastic escutcheon plate on models using chassis 306 and 308. A rear mounting position is used on receivers using chassis 307.

The 2.2-meg, $\frac{1}{2}$ -watt resistor from tuner agc to ground is deleted on chassis 306. The 4.7-meg resistor from i-f strip agc to ground is deleted on chassis 307 and 308. These resistors provide a fixed balance of agc between tuner and i-f strip and, therefore, must be removed when the variable agc circuit is used. This change can be made on earlier production of the above chassis where reception is poor because of excessive signal or fringe reception.

HOFFMAN

Chassis 306,
307, 308

Improved picture contrast in fringe areas.

The following change applies to all three of the above chassis: *R213* is changed to 2.2k-ohms, $\frac{1}{2}$ -watt resistor; *R214* is changed to a 2.7k-ohm, $\frac{1}{2}$ -watt resistor; *R711* is changed to 22k-ohm, $\frac{1}{2}$ -watt resistor. *R213* and *R214* are the video detector load resistors. *R711* is in the grid circuit of the 6BQ6GT horizontal output tube and is used to supply bias for the video amplifier tube. This change may be incorporated in any of the earlier receivers with the above chassis if weak signal is responsible for lack of picture contrast.

HOFFMAN

Chassis 306,
307, 308

Improved focus.

After a short period of service, certain picture tubes exhibit a slight change in focus characteristics. When this occurs, it becomes necessary to change the voltage applied to the focus anode of the picture tube. To remedy this condition on models using the above chassis, proceed as follows: First check the adjustment of the beam bender. If no improvement is evident, disconnect the focus anode lead (red lead to pin 6 of the crt) from chassis ground and connect to B+ boost voltage. Boost voltage is already applied to the picture tube first anode (pin 10) through an orange lead. The focus voltage connection can therefore be made at either the picture tube socket or at the chassis by connecting the red and orange picture tube leads together. Be sure the red lead is removed from ground. Readjust the beam bender for correct setting.

HOFFMAN

Chassis 407,
408, 410

Changing alignment to eliminate smear.

This change will affect the adjustment of one coil (*L202*) in the coupling network between the tuner and first picture i-f stage. Since adjustment of this coil is critical at 47.25 mc, its frequency has been raised to 47.5 mc to eliminate a tendency for slight smear of fine detail on some sets. Field adjustments of this coil may be performed by

rocking through a half turn of the coil slug while viewing a fine detail object or test pattern on the screen. Caution: Do not attempt more than one-half turn of the slug unless alignment equipment is available. Adjust for point where picture detail is sharpest.

Coil *L202* may be identified on the chassis as follows: Reference to the chassis schematic diagram shows *L201* and *L202* as traps in the coupling network between tuner and first i-f stage. Physical location of these two coils is just to the left of the i-f strip when viewing the top of the chassis from the back side of the receiver. It will be noted that the two coils are of different size. Coil *L202* is the larger coil ($\frac{3}{8}$ -inch diameter) and should be tuned to 47.5 mc. Coil *L201* is the smaller coil ($\frac{1}{4}$ -inch diameter) and should be tuned to 39.75 mc.

HOFFMAN Chassis 407,
408, 410
Improved picture brightness and focus.

The above chassis will have improved picture brightness and focus if the lead from pin 10 on the picture tube socket (this is an orange lead) is moved from its present tie-point on the 265-volt bus to the junction of *R609* and *C606*. These components, a 10k-ohm resistor and a .22- μ f capacitor, form the decoupling network to the plate circuit of the vertical oscillator. This change can be made on all "N" models and 25-inch models using the 90-degree deflection circuit. It is not necessary on chassis 470 and 408 which use the 70-degree or 74-degree deflection circuit.

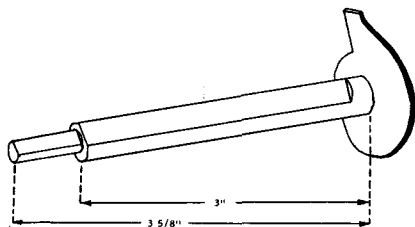

Fig. 8 — Hoffman

HOFFMAN Chassis with
tuners 9684, 9716,
9717 and 99532
Cascode tuner adaptation
(see Fig. 8).

The following information is intended for use with tuner 9788 (Standard Coil 20-mc cascode) when use as replacement for the above tuners. The shaft length must first be modified to match the length of the old tuner. To modify the shaft length, remove the screw that holds the fine tuner in place and remove fine tuning shaft. Cut fine tuning shaft to 3-inch length measured from front of dielectric wafer. Replace fine tuning shaft and cut off main shaft to $3\frac{5}{8}$ -inch length measured from front of dielectric wafer. Main shaft should be $\frac{5}{8}$ -inch longer than the fine tuning shaft when modification is completed. Be sure no metal filings are left between the fine tuning shaft and main tuner shaft.

The 9788 tuner is a cascode-type with a 20-mc i.f. having the following voltage requirements:

1. Blue or blue and white lead
—250 volts (dc)
2. Red or red and white lead
—150 volts (dc)

3. Black or black and white lead
— 6.3 volts filament (ac)
4. White or green lead
— 1.5 volts negative agc (dc)

Connect i-f output connection on side of tuner to 1st video i-f stage.

The 9788 and 9717 tuners are directly interchangeable both mechanically and electrically. One electrical change is required to substitute 9788 for 99532 (Silver Circle), 9684, and 9716. Connect red lead, black lead and white lead as indicated above. Connect blue lead to 275 volts (dc) through 1k-ohm, 1/2-watt resistor. Connect a .005- μ f capacitor from blue lead to ground.

When ordering the 9788 tuner as replacement for 99532 (Silver Circle), the following parts should also be ordered:

- 2 Tuner mounting brackets
(part No. 2529)
- 1 Tuner shaft bearing
(part No. 3768)
- 3 Screws (part No. SP160)
- 1 Channel selector knob
(part No. 33521)

HOFFMAN All chassis
Removing cabinet finish imprints.

Minor damage to cabinet finish can, in many cases, be repaired by the technician even though he has had no previous experience in cabinet work. The important considerations are patience and the exercise of care in the use of the proper finishing material. An excellent job of removing imprints and other minor finish scuffs can be accomplished with the use of Parko K-R (Kwick-Rub) rubbing compound, manufactured by the

Park Chemical Company of Detroit, Michigan. Instructions are on the container. This compound does not require further waxing or polishing after its use.

A reasonable amount of care will assure that the finish will not be accidentally cut through while rubbing. The use of this compound is, of course, only recommended for those surface defects which do not penetrate the finish. Deep scratches or gouges which penetrate into the wood must be filled before rubbing down the surface.



JACKSON Chassis 317A,
320A, 321A, 324A

Checking agc circuit.

In order to check the keyed agc circuit for proper operation, the following simple test will be useful. When the grid of the agc key tube (pin 1, *V13*) is shorted to the cathode (pin 7) the voltage on the agc bus (across *C24* 0.5- μ f capacitor) should be approximately 40 to 70 volts negative as measured with a vtvm. In the event that this voltage is not obtained, the trouble will probably be in the key tube *V13*, the horizontal output transformer *T5*, in one of the coupling or bypass capacitors in the agc line, or in the agc filter resistors.

JACKSON Chassis 317A,
320A, 321A, 324A
Replacement of i-f tubes.

Occasionally 6AG5 tubes are used in place of the 6CB6 tubes speci-

ified in the service notes for the i-f amplifiers *V3*, *V4*, and *V5*. It should be noted that these tubes are *not* directly interchangeable due to the different internal wiring of the tubes. Therefore, when replacing these tubes, be sure to use the same type that was originally supplied in the receiver. If 6AG6 tubes were originally used, this type of number will appear on the chassis near the tubes.



KAYE-HALBERT Chassis 263
Excessive current through vertical linearity control.

In cases where excessive current is being drawn through the vertical linearity control, it is suggested that the following changes be made:

Substitute 2,000-ohm, 2-watt, wire wound linear taper control (part No. 138) for the existing linearity control. Remove 220-ohm, 1/2-watt resistor in cathode circuit of vertical output tube. In its place use two 1,200-ohm, 1-watt resistors in parallel.

This arrangement will prevent excessive current through the control.



MAGNAVOX Chassis 103-series
Signal overload.

In very strong signal areas, some overload may be experienced on this chassis. This condition may be corrected by changing *R164*, connected to the pin 4 grid of the agc clamp tube, from 1.8 meg to 2.7 meg.

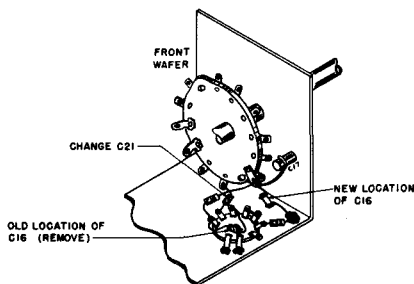

Fig. 9 — Magnavox

MAGNAVOX Chassis 103-series
Correcting sound drift
 (see Fig. 9).

The above series chassis is mounted vertically in some cabinets, and the heat rising to the tuner may cause some oscillator drift. The changes outlined below were made in later production to compensate for this, and if found necessary in early chassis, may be incorporated in the field.

1. Replace *C21*, 10- μ mf capacitor (black, brown, black, black, white) with 10- μ mf, N750 capacitor (violet, brown, black, black, white), part No. 250088G63. *C21* is the capacitor connected to the front lug at the base of the front wafer.

2. Remove *C16*, 3- μ mf N750 capacitor (violet, black, orange, black) from oscillator socket.

3. Add 3- μ mf, N1800 capacitor (orange, orange, black, orange, black, green), part No. 250088G57, from rear lug at bottom of front wafer (connection point for *C17* oscillator trimmer) to chassis ground in front of oscillator socket (connection point for *C22*). Keep leads as short as possible.

Check oscillator alignment on channel 13 (or on highest channel station) to see if the oscillator tunes in with fine tuner not too close to either end of its rotation. If not, adjust oscillator trimmer *C17* (in the front apron of tuner) with screwdriver.

Check oscillator alignment on all other channels (or on all available stations) to see if all other channels tune in with fine tuner not too close to either end of its rotation. If any channel does not tune in or tunes too close to either end of the fine tuner rotation, adjust the inductance of the oscillator coil for that channel. Then check all lower channels, adjusting their coils also, if necessary. Re-check tuning of all channels after the last coil is adjusted.

Although the above changes should correct this difficulty, in persistent cases change *C18*, 100- μ mf capacitor to part No. 250088-13, 100- μ mf, N750 unit. It is also advisable to check the 22,000-ohm oscillator grid resistor *R9*, as this will sometimes change value with temperature increases. Changing *C18* and *R9* may also help in curing a similar complaint on the horizontally mounted chassis, but *C16* and *C21* should not be changed in this case.

MAGNAVOX Chassis 104-series
Improving sensitivity and sync stability in fringe areas
(see Fig. 10).

In extreme fringe areas, gain and sync stability may be improved by making one or more of the circuit changes listed below. Care should be

exercised in making these changes, as the reception of strong signals may be impaired.

To improve sensitivity:

1. Raise r-f screen voltage by lifting orange lead of tuner from +150 v and connecting to +210 v white lead.

2. Ground green lead (agc) from tuner and remove *R109*, (100k-ohm resistor in agc bus to tuner).

3. Change *R172* (in grid circuit of audio output) to 820k ohms to produce +160 volts on i-f plates.

To reduce snow and reject strong noise impulses:

1. Change *R14*, 100k-ohm resistor in mixer grid circuit, to 47k ohms (this has already been done in some models), and ground the test point.

2. Add r-f choke (10 to 40 microhenrys) across 1st i-f grid load resistor (*R113*). Check i-f curve after this change, as carrier will move down on curve. Touching up *T104* (final i-f transformer) may be all that is necessary.

To improve noise immunity for better sync stability:

1. Change *R134* (10k ohms), connected between video amplifier and sync amplifier, to 27k ohms.

2. See diagram for addition of noise diode.

MAGNAVOX Chassis 104-series
Removing adjacent channel interference.

To remove adjacent channel interference where necessary, install trap No. 360457-1 from 1st i-f plate to ground and tune to 27.25 mc.

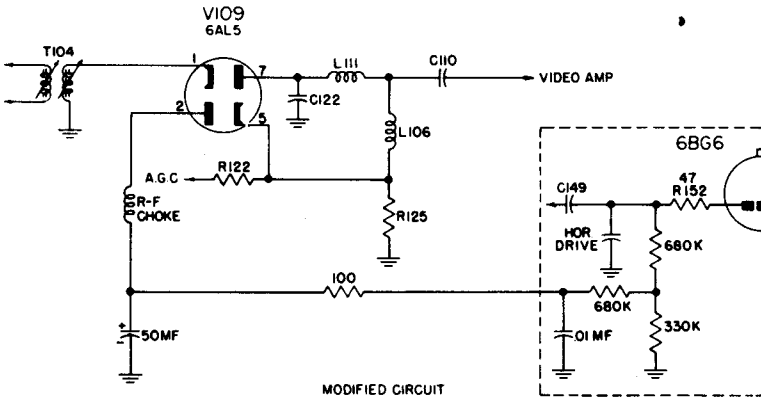
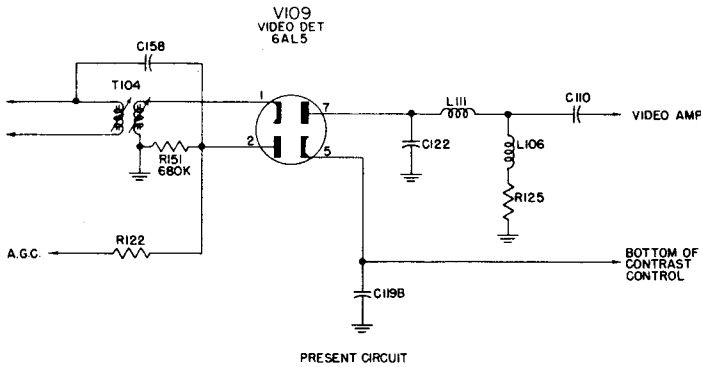

Fig. 10 — Magnavox

For rejection of a 19.75-mc signal, connect trap to the plate of the 2nd i-f amplifier.

MAGNAVOX Chassis 105-, 106-, 107-series
Troubleshooting "sync lockout"
(see Fig. 11).

In servicing the above series television chassis you will occasionally find one which exhibits a condition commonly referred to as "sync lock-out". This condition is recognizable by the complete absence of horizontal

and/or vertical sync; sometimes pulsating and occasionally accompanied by a loss of contrast. As this trouble can originate in a number of circuits, it is necessary that a definite system of troubleshooting be used. The information given below and followed in the sequence listed will save much time and effort in locating the source of the trouble in such cases.

For chassis 105-series with 21-mc i.f.

1. Check all tubes, particularly tuner, 1st, 2nd, 3rd i-f, video detector,

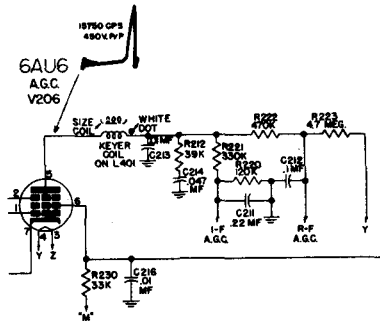

Fig. 11 — Magnavox

sound i-f, noise inverter, sync amplifier, horizontal oscillator output tubes.

2. Check the voltage on the grid of the noise inverter. This should be not less than -13 v (measured on vtm) with the noise bias pot set in maximum clockwise position. This tube (*V301A*) is normally biased to cut-off and does not conduct except under noise pulses exceeding the average signal in voltage amplitude. The conduction point of the tube can be anything you care to make it depending upon the noise bias adjustment. If you cannot reach the value of -13 v first check the drive adjustment. This should be backed out and set to a point slightly before horizontal drive lines begin to appear. Check the voltage (with a vtm, as all these voltages should be checked) on the grid of the 6BQ6 horizontal output tube. This voltage must be at least -25 v otherwise the noise inverter bias can never be brought up to -13 v. If insufficiently high, change the 6BQ6. If you can achieve -13 v bias on the noise inverter grid and sync lockout con-

tinues, you can discount any further trouble in this direction and must turn elsewhere.

3. Check terminal voltages on i-f plate and screen terminals, on keyer tube, on noise inverter, on video amplifier and the others pertaining to the tubes checked under step (1) above.

4. See if the set is developing proper agc. With no signal, bias on the r-f tuner will be about 0.6 v positive. I-f bias will be slightly over 0.5 volt negative. As signal is applied on antenna, both biases will rise to more negative values. At $5,000 \mu\text{v}$, for example, bias on i-f stages will be about -3.5 v; on r-f stages, -1.5 v. These voltages are slightly different between the early and late chassis. The main thing to check is the ability of the two agc buses to show a voltage rise and fall as the antenna is coupled and decoupled from the input terminals.

5. If sync lockout takes place with normal signal input from the antenna, loosely couple antenna twinlead to input terminals and watch the bias. If there is a normal fall-off toward the values indicated under condition of zero signal (see above), it can be assumed that the biasing network is functioning properly.

6. If bias is not being developed at all, the amplitude of the keying spike on the plate of the agc keyer is the first check. This should be about 440 volts, with no leading or trailing spikes of a sufficient amplitude to cause the keyer to fire prematurely or for a period past that of the main spike. If the keyer pulse is not good, check the pulse on pin 5 of the horizontal output transformer.

This should be negative in polarity and about one-quarter the amplitude of the pulse on the keyer coil secondary.

7. Check terminal voltages on pins of agc keyer tube.

8. If agc is being developed but not in proper relationship, check the biasing network. This can be checked by unsoldering one end of *R223* (see figure); each resistor can then be measured separately. Check *C211*, *C212* and *C214* for open or short.

9. The operation of the set should be checked with brightness at maximum. When the picture tube operates at maximum brightness, the 210-v cathode voltage on the keyer drops slightly (it is common to the cathode of the picture tube). This changes the keyer tube's conduction point by varying the cathode-grid bias.

10. Check the degree of compression of sync into video, if any, that may be developing from the output of the tuner to the grid of the video detector. In a strong signal area, you should see enough output from the tuner at the grid of the 1st i-f stage to determine if there is any "crushing". Following, in succession, the grids and plates of each i-f stage, a gain should be realized through each stage, without compression. (You can experimentally note the effects of compression by temporarily misaligning an i-f stage and watching the sync compress with respect to the video. Care should be taken to reset the slug to the original position.) If compression exists in a stage, disconnect the transformer loading it, then check both windings for continuity or a short between the windings.

11. The next logical step is to check alignment. First, peak-align the different slugs with a marker generator. (This includes traps in sets having them, which are aligned for null signal.) Then touch up the curve by sweep-aligning through the front end with an r-f signal; say, channel 5 or any free channel. You can, if desired, sweep-align on i-f alone but this may not tell the story if something happens to be wrong in the tuner. Misalignment can usually be detected by noting the appearance of phase-shift tuning images on a particular scene on the picture tube. These displace each other when the fine-tuning control is turned. Such a set working in a strong signal area will almost surely have sync lockout.

12. If the set is being operated in an exceedingly strong signal area, it may be necessary to reduce the gain of the 3rd i-f stage slightly (to prevent overloading the detector) by making the change as shown under "Signal Blocking in Strong Signal Areas" for chassis 105-series.

13. Check the voltages to chassis on the screens and plates of the i-f tubes, the tuner and video detector more thoroughly than before. Since the first tube that receives the full B+ voltage roughly halves it, the screen and plate voltages on the 2nd i-f should be 260 volts; on the 1st i-f, 125 volts; on the 3rd i-f, 260 volts; on the video detector, 125 volts. Sometimes a fault occurs in one of these stages due to voltage breakdown within the tube itself that is not apparent when the tube is checked in a tester. Leave a voltmeter probe on either of the two stages that receive the dropped volt-

age; a gradual change will indicate a defective tube.

14. Sync lockout can also occur in the event of troubles existing in the sync separator, sync amplifier, sync clipper, horizontal afc, horizontal oscillator or output stage. If all the foregoing steps have been checked and found normal, and if the picture tends to roll vertically as well as being in horizontal lockout, a leaky coupling capacitor between the agc keyer and sync separator (*C309* particularly), between the separator sync amplifier (*C310*); between the amplifier and clipper (*C311*); between the clipper and horizontal afc (*C304*) can be suspected. Using a scope and low capacitance probe, check the waveforms before the stages mentioned. The resultant waveform on the grid of the afc tube should be a clean, stable spike of about 20 volts p-p. The reasoning behind experiencing lockout here is that in the event of discontinuity in the sync chain feeding the afc, the horizontal oscillator will run at random frequency. This results in delivering this voltage to the keyer tube through the keyer coil at an incorrect time with respect to the transmitted sync signal which is delivered to the grid of the keyer (the grid and plate pulse should be applied to the tube simultaneously). This is required in order that the agc charging capacitor *C213* be permitted to charge and then discharge exponentially to furnish bias during the time no sync is transmitted (the picture time).

15. Horizontal afc troubles sometimes appear as though they might be

sync lockout. A low-capacitance probe placed on the grid of the horizontal oscillator should show the feedback horizontal oscillator (15.75 kc) waveform on top of which rides the referencing sync pulse. Here again, to achieve stability enough to check this, it may be necessary to decouple the antenna to the point where the lockout disappears. If it does not (and the foregoing have been checked) and the picture does not go out of sync vertically, check the afc.

For chassis 105-series with 41-mc i.f.

1. This chassis has different agc curve characteristics, but is basically the same as the 21-mc chassis except for the detector arrangement and the associated stage power-stacking. The important point here is to check the front-to-back ratio of the crystal detector (front resistance reading on a 20,000 ohm-per-volt meter should be 400 to 600 ohms; back resistance about 100k ohms). This check still pertains to sync lockout.

2. Check *L201* (peaking coil connected from lug *F* of video detector can to ground) and *L206* (grid coil of sound i-f stage) for opens; also 4.5-mc sound takeoff coil.

3. Check *C207* (coupling capacitor to grid coil of sound i-f stage) for leakage.

4. Check continuity from *D* to *F* of the video detector can. This should give the front-to-back ratio of the crystal just as if you were to disconnect the crystal and check it independently.

5. Often, due to changed characteristics of the 44.1-mc transformer in the crystal detector can, you will find that when checking the waveform on

the grid of the 3rd video i-f with a demodulator probe, the composite sync looks good. If it is compressed on the plate side, due to the signal feeding a subsequently lower impedance load, replace the entire can, with a transformer. (This only has to be done after the output circuit components mentioned in steps (1) to (4) above have been checked).

For chassis 106-, 107-series:

1. These are identical with the 105N chassis respecting sync lockout problems except for an additional video amplifier. The 6K6 can be checked as a matter of course.

Important:

In normal signal areas, considerable service callbacks can be avoided by disabling the noise inverter. This is done in the field without the necessity of pulling the chassis by clipping off pin 8 of the noise inverter tube (cathode). The reasoning behind this is as follows: The noise inverter bias is normally set for the tube to conduct on noise above a given signal level. If this level is higher than the highest available noise pulse, then the tube will never have occasion to operate. Its employment, however, is still subject to the maintenance of at least -13 v of bias for proper operation. If the grid characteristics of the 6BQ6 change, the bias is reduced and the noise inverter tube will conduct on signal rather than noise.

Needless to say, the foregoing paragraph should be considered as preventive maintenance rather than a cure for sync lockout and should not be used as a cure-all.

It may be helpful to obtain a signal just below the verge of sync lockout.

Under this condition, if sync is crushed at the plate of the video amplifier but not at the grid of the video amplifier, then one of the following conditions usually prevails.

1. Insufficient sync to provide satisfactory operation of the sync circuits.

2. Inadequate agc, which permits the i-f out put to be so high as to overdrive the grid of the video amplifier. This can best be checked by comparing the a-c output of the video detector with the value obtained in a receiver which does not exhibit sync lockout.

A separate d-c bias supply consisting of a 15-volt battery shunted by a 50,000-ohm potentiometer would be helpful in troubleshooting the lockout. Remove the agc amplifier tube and connect the bias supply from the plate circuit of the agc amplifier to chassis. Try various values of bias and trace the sync pulse through the circuits with a scope. This will eliminate the effects of agc malfunction and facilitate locating the trouble should it not be in the agc system.

MAGNAVOX Chassis 105-series **Reducing background noise in picture.**

To reduce background noise in the picture, proceed as follows:

1. Change R223 from 4.7 meg to 3.9 meg. This resistor is in the plate circuit of the agc keyer tube.

2. Remove 10k-ohm resistor, R231, in the 2nd i-f grid return. (Note: R231 is not used in A and B models.)

MAGNAVOX Chassis 105-series
Improved vertical sync in weak signal areas.

In weak signal areas, R_{215} in age grid circuit, should be 27k ohms. In some chassis, 10k ohms has been used.

MAGNAVOX Chassis 105-series
Critical horizontal drive or "motorboating" sync
(see Fig. 12).

If horizontal drive adjustment appears too critical, or if horizontal and vertical sync "motorboat", install noise inverter bias control as shown.

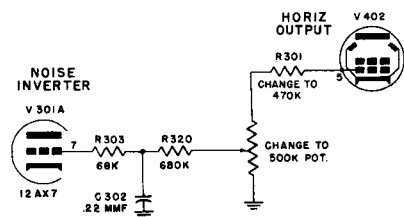

Fig. 12 — Magnavox

This control can be installed in place of color converter jack.

Adjust noise bias control for most stable sync.

Align horizontal oscillator and afc.

MAGNAVOX Chassis 105-series
Signal blocking in strong signal areas (see Fig. 13).

If signal blocks when tuning from weak to strong signals, proceed as follows:

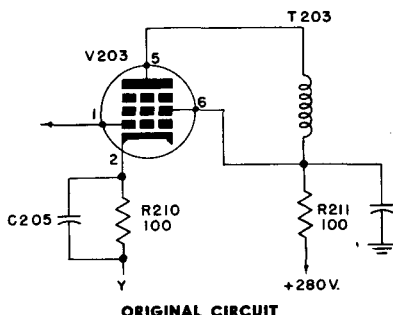

ORIGINAL CIRCUIT

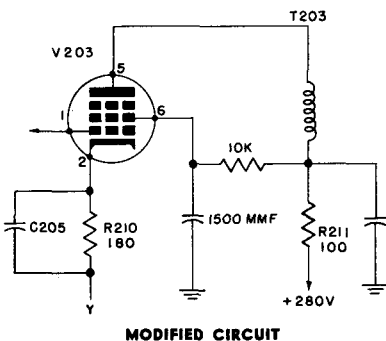

MODIFIED CIRCUIT

Fig. 13 — Magnavox

1. Check noise inverter bias. This should be approximately -11 volts, and may be raised by adjustment of the horizontal drive control or noise bias if used.

2. Replace V_{206} , age amplifier tube.

3. Blocking may be due to excessive grid current in V_{203} , the 3rd video i-f amplifier. This circuit may be modified as shown in the illustration.

MAGNAVOX Chassis 105-series
Eliminating audio hum.

1. In a few cases, the input and output leads to the volume control

were reversed. Check for this condition and correct if required.

2. Check for incorrect connection of red lead from audio output transformer. This lead should go through decoupling resistor to +280 volts. In some cases, it was connected directly to +250 volts. (If hum is from this source, it will vary in tone with rotation of vertical hold control.)

3. A few audio output transformers were improperly phased. This usually causes audio oscillation, and can be easily checked by disconnecting *R113* (100-ohm feedback resistor). Audio output should increase. If a decrease in output is observed, the transformer secondary leads should be reversed.

4. Check 10-ohm resistor (*R112*) in cathode circuit of 6T8. In some cases 100 ohms has been used.

5. Try a new 6T8 tube.

6. Reroute leads to Off-On switch. Follow contour of chassis, and keep leads as far as possible from audio grid.

MAGNAVOX Chassis 105N-series "Pie-crusting" or jagged picture at high line voltage.

If "pie-crusting" or jagged picture is experienced at high line voltage on the above series chassis (CT372N, CT390N, etc.) the following corrections should be applied:

1. Disconnect *R420* (3,900-ohm screen dropping resistor of horizontal output tube) from the +250 volt supply and connect it to the black lead from the deflection yoke.

2. It will now be necessary to re-adjust the centering and horizontal linearity. Two positions of the line-

arity slug will be found to offer uniform horizontal linearity. Choose the position nearer maximum inductance.

3. If this does not effect a complete cure, shunt *C417* (.047- μ f capacitor connected between plate voltage supply line to horizontal oscillator and ground), with a 10- μ f electrolytic capacitor.

MAGNAVOX Chassis 107-series Width coil adjustment.

If it becomes necessary to move the slug in the width coil of the above chassis to within $\frac{1}{4}$ inch of its maximum outward position to obtain proper width, remove the .0068- μ f capacitor (*C417*) across the coil and re-adjust.

With the width coil slug in the outward position, the minimum inductance is well below specified minimum resulting in overheating and burning of the width and keyer coils.

The above procedure will be necessary only on early chassis, as the coil specifications were changed in later production and the value of capacitor *C417* changed to .0022 μ f.

MAGNAVOX Chassis 108-series Reducing hum and buzz (see Fig. 14).

The schematic diagrams shown here illustrate the circuit revisions used for reducing hum and buzz in the above series chassis when necessary. Notes on the schematic diagrams indicate important points to check when making these changes to insure proper operation.

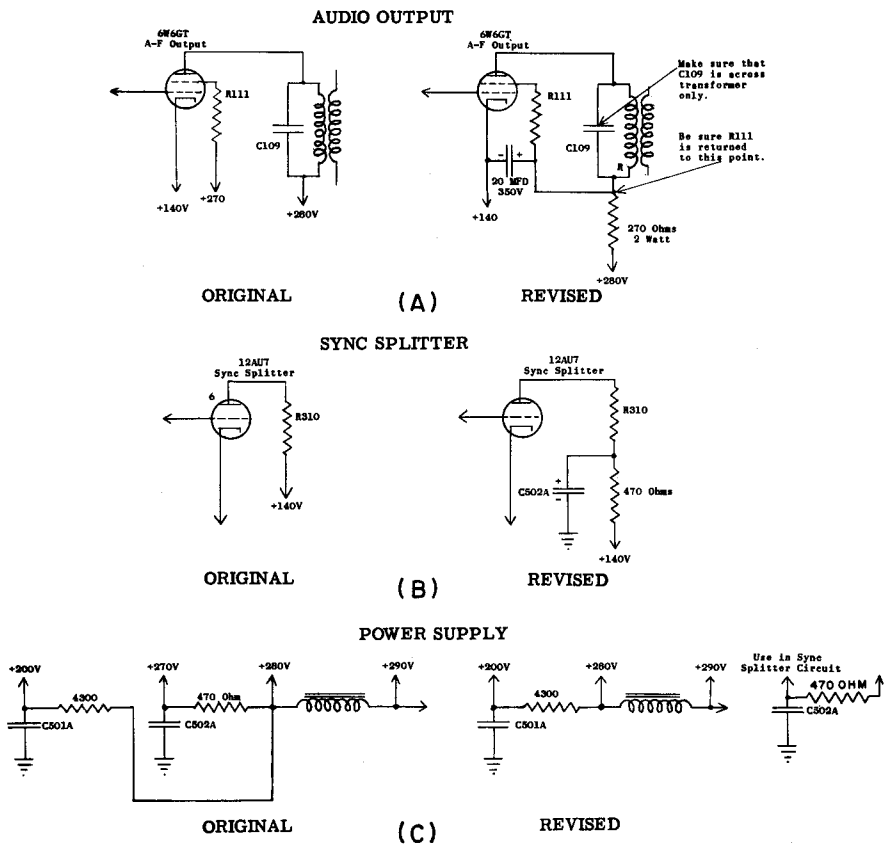

Fig. 14 — Magnavox

The changes involve the addition of decoupling filters in the audio output and sync splitter stages. Note that the components required for the sync splitter may be obtained from the power supply circuit.

MAGNAVOX Chassis 250-series Focus adjustment.

All the above series chassis (vertical type) use electrostatic focus

tubes in both 17-inch and 21-inch models. Most of these tubes are designed to have optimum focus with the focus electrode grounded. Others are designed to connect the focus anode to 500 volts (high side of C413).

In later production, a terminal strip with two pin jacks is incorporated on the rear of the chassis. One will be at ground potential and the other at the 500-volt B+ boost volt-

MAGNAVOX All chassis with uhf
**Black lines or blotches on right
side of raster.**

Black lines or blotches (sometimes called "snivets") may appear on the right-hand side of the raster on a television picture tube. These are quite prevalent in the uhf band in most manufacturers' receivers, and can be ignored unless they occur on a channel where the signal is not strong enough to override them. In such severe cases, they can be eliminated or moved to a different part of the spectrum by changing the horizontal output tube (6BQ6 or 6CD6).

MAGNAVOX All chassis with
700458-1 tuner

Oscillator adjustment.

Extreme care should be exercised if it becomes necessary to adjust the oscillator slugs for channel 6 or 13 on the above 13-position vhf tuner. The coils tuned by these slugs are self-supporting and the slug is threaded into the wafer. Be careful not to compress the turns or damage the coil. The blade of the screwdriver used should be no wider than the slot in the slug and it must be inserted straight.

MAGNAVOX All chassis with
74-degree picture tube
**Height and vertical linearity
adjustments.**

Receivers shipped from the factory have all rear chassis controls preset for normal operation. To allow for picture shrinkage, line voltage variations and transmitter blank-

ing time variations, the tube is usually overswept in both horizontal and vertical directions so that the screen will always be filled completely.

The 74-degree picture tube with its higher screen (the width is the same as for 70-degree tubes) demands greater care in setting the height and linearity controls. If it is apparent that these preset controls are out of adjustment, operate the receiver for at least 15 minutes, then overscan vertically $\frac{1}{4}$ -inch at the top and $\frac{1}{2}$ -inch at the bottom. Should it be impossible to fill the screen during this adjustment or if there is foldover at the bottom, replace the vertical output tube, or if necessary, the vertical output transformer.



MAJESTIC

Chassis 112-,
113-series

**Poor vertical linearity or
insufficient height.**

Poor vertical linearity or insufficient vertical size, may be due to a change in the characteristics of *V13*, 6V6, the vertical output tube. To remedy, rewire vertical output circuit as follows:

1. Remove *R65*, 47k ohms, 1 watt, connected to pin 4 of *V13*, 6V6. Do not connect a short across this resistor, but leave this circuit open.

2. Connect pin 3 to pin 4 of *V13*, 6V6 socket. *C51*, .25- μ f, 600-volt capacitor, may be removed as it is now shorted out of the circuit.

3. Readjust vertical size and vertical linearity controls as outlined in the service notes.

Note: Some sets in the above series may already incorporate the above change.

MAJESTIC Chassis 115, 116,
117, 118, 119,
120, 121, 122

Improving sync stability
(see Fig. 16).

The following changes, already made in later production of the above chassis (coded with suffix letter *A* following chassis series code) are incorporated in order to provide improved sync stability. These changes also allow the Sync Stability control to be further advanced for noise immunity in high signal areas.

1. Add 10k-ohm, $\pm 20\%$, $\frac{1}{2}$ -watt resistor in series with sync input lead.

2. Add 390k-ohm, $\pm 10\%$, $\frac{1}{2}$ -watt resistor in series with sync separator control grid.

3. Add 1,500 μmf , $\pm 20\%$, ceramic capacitor in series with sync separator control grid.

4. Change sync separator grid resistor from 470k ohms to 680k ohms, $\pm 10\%$, $\frac{1}{2}$ watt.

5. Add 56k-ohm, $\pm 10\%$, $\frac{1}{2}$ -watt resistor from pin 4 of sync amplifier 6SN7 to ground.

6. Remove 33k-ohm plate resistor of vertical sync amplifier and connect plate (pin 2) to 250-volt B+ instead of 135-volt B+.

7. A 6CS6 tube may be used in place of the 6BE6 tube. Tubes are directly interchangeable.

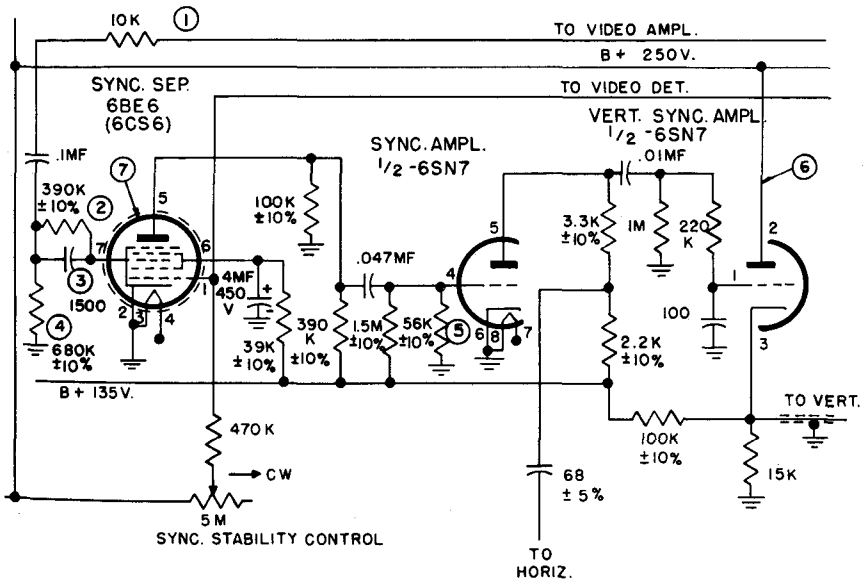

Fig. 16 — Majestic

The schematic diagram shows the revised sync amplifier circuits, with the circled numbers corresponding with the numbered steps above.

MAJESTIC Combinations
with a-m/f-m chassis
801, 802

Excessive drift on fm after warm-up.

In the event of excessive drift on fm after a 15-minute warm-up, proceed as follows:

Replace f-m oscillator capacitor, *C12*, 4.7- μmf ceramic unit, with a 5- μmf ceramic capacitor having a temperature coefficient of N750 (part No. B-4.137-1). *C12* is located on top of the ganged tuning capacitor.

The following is a simplified field alignment procedure for use with the above replacement. Before replacing the capacitor, turn on the receiver and tune in an f-m station closest in frequency to 108 mc. Shut down the receiver, replace capacitor *C12* with temperature compensated capacitor. Turn on the receiver, and without touching main tuning capacitor, adjust *C11*, f-m oscillator trimmer (located on top of tuning capacitor) until the same f-m station is received at that same point on the dial.

Note: Tv combination models 21P64, 21P65, 21P72, 21P73, 21PR80 and 21PR81 already have the temperature compensated capacitor.



MARS TV Model 630-K3B
Extreme fringe area alignment
(see Fig. 17).

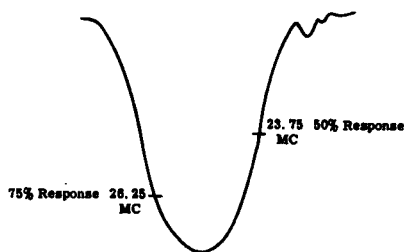

Fig. 17 — Mars

For extremely difficult fringe area coverage where signal-to-noise ratio is a problem, it is possible to narrow the 4-mc i-f bandwidth to 2 1/2 mc to obtain extra gain and a better signal-to-noise ratio. It has been found that in the nominal 100 to 150 mile sector where video reception is possible but not comfortably viewable, the 2 1/2-mc bandwidth will in most cases bring in the picture to a suitable viewable point, minimizing snow.

The procedure for such alignment on the above model normally, is to attach a signal generator to the shield of the converter tube on the tuner, after lifting the shield off ground, and align four i-f stages and the converter coil to the following frequencies:

- 4th i-f 22.75 mc
- 3rd i-f 25.9 mc
- 2nd i-f 23.9 mc
- 1st i-f 24.5 mc

converter coil 26.4 mc

Make sure to readjust all the traps to their proper frequencies (as listed on the schematic circuit diagram) before and after spot alignment. Then remove the signal generator and con-

nect a sweep generator to the antenna input at any one of the low frequency channels and touch up the i-f coils for the response indicated in the illustration, making sure that the 26.25-mc point and the 23.75-mc point are adjusted as indicated on the curve. Should any of the i-f's require more than a touch-up, the trap associated with that stage must be retuned. It is usually a good procedure to recheck all the traps after sweep alignment.

While aligning, use a 1.5-volt battery connected at the junction of *R130* (100 k) and *C134* (.5 μ f to ground). This is the agc point of the receiver. A 1.5-volt battery at this point biases the first three i-f stages and the r-f stages at 1.5 volts, and will prevent regeneration while aligning. In areas where all signals are below the 200-microvolt level (that is approximately one-to-one signal-to-noise ratio), it is generally advisable to short this point to ground to eliminate contact potential generated by the agc tube. However, if any signals are present above the 200-microvolt level, the receiver will overload if this point is grounded.

If no sweep generator is available, spot frequency alignment will reproduce the curve approximately, but not accurately, and spot alignment without sweep alignment should only be used as a last resort.

The above information should be sufficient to bring in a signal under most conditions where a signal is receivable. Beyond this point, special antennas, boosters, or other equipment may be required, or else the signals are non-receivable.



MATTISON TV Models 630-6A,
630-6B

Barkhausen oscillations.

Under certain operating conditions, the horizontal output circuit may produce spurious signals of a type known as "Barkhausen oscillations". These signals cause one or more dark vertical stripes to appear in the picture on some channels, usually on the left-hand side.

In order to eliminate them, take the following steps in order:

1. Reduce the horizontal drive (turn the horizontal drive trimmer screw clockwise).
2. Dress the antenna lead-in away from the h-v cage and power line cord.
3. Replace the 6BG6G horizontal output tube.
4. Replace the deflection yoke.
5. Replace the horizontal output (flyback) transformer.



MECK Chassis 9026,
9032, 9033, 9034

Preventing horizontal pulling and S-distortion.

To prevent horizontal pulling and S-distortion, the following changes already made in later production, are incorporated:

1. Resistor *R59*, 1-meg resistor connected to pin 6 (plate) of the phase detector, *V10A* (12AX7), is changed to 680k ohms.

2. Capacitor C53, 430- μ f capacitor connected to pin 1 (plate) of sync clipper, V9B (12AU7), is changed to 270 μ f.

MECK Chassis 9026,
9032, 9033, 9034

Preventing vertical jitter.

To prevent vertical jitter, C11, .01- μ f capacitor, is added between the cathodes (pin 3 or 6) and ground of V2, vertical oscillator (6SN7). This change has already been made in later production.

MECK Chassis 9026,
9032, 9033, 9034

Extending range of vertical size control.

The range of the vertical size control is extended by the following:

1. Resistor R15, connected between the plate (pin 2) of the vertical oscillator and the high side of the vertical size control, is changed to 820k ohms.

2. Capacitor C13, connected between the plate (pin 2) of the vertical oscillator and pin 4 of the picture tube, is changed to .1 μ f. These changes are already made in later production.

MECK Chassis 9043, 9044,
9045, 9047, 9048,
9049, 9050, 9051,
9053, 9054, 9055

Preventing audio buzz.

When the following leads are properly dressed, they will aid in the

correction of audio buzz. However, the sound alignment should be thoroughly checked before condemning any lead dress of the chassis.

1. The yellow and the black twisted leads from the volume control to the 15k-ohm resistor of the ratio detector should be dressed away from all components in the vertical circuits as much as possible. These leads should remain as close to the chassis as possible.

2. The blue lead from the primary of the audio output transformer to the plate of the 6V6 tube should be dressed away from the yellow and black twisted leads leading from the volume control to the grid (pin 2) of the 12AX7 tube.

3. The green lead leading from the vertical speed control to the 1-meg resistor should be dressed away from all components as much as possible. Do not dress this lead close to the chassis.

MECK Chassis 9043, 9044,
9045

Reducing tube and component failure in high line voltage areas.

In communities where the line voltage runs consistently above 120 volts at the tv receiver, the addition of 3.0- to 3.3-ohm, 10-watt wirewound resistor in series with the primary of the power transformer will reduce tube and component parts failures, particularly in the scanning and the high-voltage circuits. Receivers are designed for operation from 105 to 125 volts with voltages below 110 and above 120 being considered short time abnormal conditions.

MECK

Chassis 9043, 9044,
9045 with uhf tuner

Changing output frequency of uhf tuner.

The uhf tuner unit in these receivers is designed to operate so that its output is amplified by the vhf tuner when the vhf tuner is switched to either channel 5 or 6. The unused channel is used for uhf. In the event it is desired to change the channel, it can be readily accomplished of means of two hex head screws which are accessible from the underside of the cabinet through the ventilation opening between the chassis mounting rails. These screws hold the switching cam (a sheet metal piece with a right-angle bend on its outer end and a triangular shaped cam surface which bears against a roller that is mounted on the switch) to a hub which is fastened to the vhf turret shaft extension. To effect the change from 5 to 6 or vice versa, loosen the two hex head screws and move the sheet metal cam 30 degrees to the other end of the slot of the slotted holes in the cam.

Under some circumstances, it may be necessary to readjust the hub which holds the cam on the turret shaft. This is accomplished by loosening the 6-32 setscrew by means of a small Allen wrench and repositioning the hub on the turret shaft. This should be done only as a last resort because the turret shaft has a flat which is intended to index the hub. But if loosened, be sure not to disturb the front-to-back position of the hub on the turret shaft because this positioning controls the amount of

switch throw which was previously properly adjusted at the factory.



MONTGOMERY WARD Models
25BR-3058, -3061,
-3067, -3068, -3069;
35BR-3158, -3167,
-3168, -3169

Replacement of protective device.

Due to procurement difficulties, the receiver protective device has been modified and relocated as a temporary measure on some of the above model sets. This change was made only on those sets produced between production code dates of 311 and 313 after which production reverted back to using the fusible resistor, part No. 46M-20681.

A 7.5-ohm, 5-watt resistor (part No. B-92-22503) and a 1.6-amp., 125-volt fuse (part No. A46B-2250A) combination is used in place of the fusible resistor on all production between the above code dates. The 7.5-ohm resistor is located adjacent to the selenium rectifiers on top of the chassis and the 1.6-amp. fuse is located under the chassis near the selenium rectifiers.

If replacement is necessary, the same parts should be obtained and used if possible. If, however, the exact replacement parts are not available, the fusible resistor, part No. 46M-20684, may be used as a replacement. If the fusible resistor is used as a replacement, the 7.5-ohm resistor must be removed and the fusible resistor substituted in its

place. Secondly, the 1.6-amp. fuse must be shorted out when the fusible resistor is installed.

MONTGOMERY WARD Models
25BR-3058, -3061,
-3067, -3068, -3069;
35BR-3158, -3167,
-3168, -3169

Failure of doubler electrolytics.

The 100- μ f, 150-v electrolytic capacitors *C90* and *C91* have shown a tendency to fail after a short period of time in the above sets. The capacitors *C90* and *C91* are identical with the exception that *C90* has an insulated cardboard case over the capacitor. The failures have been traced to the inability of capacitor *C90*, part No. 8C-20709, to dissipate heat due to the insulated case surrounding the capacitor with the result that it would fail.

In later production, this has been corrected with the use of capacitors that have a higher temperature rating and which do not have an insulated cardboard case surrounding the capacitor. When failure of *C90* or *C91* is encountered in the field, replace it with part No. 8C-20709-1, which is an exact replacement. This is the un-insulated capacitor which has the higher temperature rating used in current production.

MONTGOMERY WARD Models
25BR-3058, -3061,
-3067, -3068, -3069;
35BR-3158, -3167,
-3168

Shading on left side of raster.

To correct shading on the left side of the raster, proceed as follows:

1. Remove the 1,000- μ f capacitor connected between pin 5 of the 6AX4GT damper tube and chassis.

2. Install a .01- μ f capacitor between pin 5 of the 6AX4GT damper tube and chassis.

The above change has already been incorporated in later production.

MONTGOMERY WARD Models
25WG- and
35WG-series

Intermittent horizontal jitter, tearing, bending, foldover, and inoperative horizontal oscillator.

Occasionally one of the above models is received for repair on which one or more of the conditions indicated in the heading are observed and it becomes very difficult or impossible to locate the defective part causing the trouble. When you encounter any of the above conditions which you cannot locate with normal checking, the B+ filters should be checked for intermittents. Especially check filters on the B+ bleeder network adjacent to the tap connected to the horizontal sweep section.

The filters should be checked for intermittents by moving the capacitor solder lugs slightly with a nonmetallic tool, observing the picture for any of the above conditions. In some cases, it may be necessary to operate the set for long periods of time for the trouble to reappear after you have once moved any of the capacitor solder lugs. The filter capacitor should be replaced if any movement of the solder lugs causes any of the above conditions to appear or disappear.

It is important to remember that these B+ filters can be intermittent and no effects will be noted in the audio, raster edge or in the voltage readings, but they will have an effect on the operation of the horizontal sweep section.

MONTGOMERY WARD Models
25WG-3071D,
-3073D, 35WG-3060B,
-3070B

Installation of uhf strips.

Uhf strips may be inserted into the tuner of this receiver without removing the chassis from the cabinet. Turn the cabinet upside down on top of a clean sheet of paper or cloth to avoid marring the finish of the cabinet. You will note an opening in the cabinet located directly below the tuner. Remove the protective cover from the opening and take off the tuner bottom cover. The tuner is now accessible for the removal of any vhf strip and the addition of any uhf strip. After the uhf strip has been inserted into the tuner, the bottom cover on the tuner and the protective cover on the cabinet have been replaced, turn the cabinet right side up.

Because of the addition of the uhf strip, an adjustment of the r-f oscillator will be necessary. Remove the channel selector and fine tuning knobs from the tuning shaft and proceed as follows:

1. Set Channel selector to receive the desired uhf station.
2. Set fine tuning control in center of its range.
3. Through the clearance hole in the cabinet adjust the oscillator slug

with a bakelite-type screwdriver for best picture resolution.

4. Repeat steps 1, 2 and 3 on all channels used.

MONTGOMERY WARD Models
25WG-3071,
-3072, -3073,
-3075, -3077, -3079

Vertical Instability.

The above models may show signs of vertical instability after one hour to two weeks of operation. The first indication of the set developing this trouble is the positioning of the vertical hold control toward the extreme right-hand position in order to be able to stop the picture from rolling vertically. To correct this condition, proceed as follows:

1. Remove the 6BL7 tube and in its place install a 6SN7GTA tube. Be sure to use a 6SN7GTA, which has a higher wattage rating and which will operate much more satisfactorily than a 6SN7GT in this application. Then adjust the vertical linearity and vertical size to fill the screen. In the event that you cannot fill the screen by using the 6SN7GTA due to the low line voltage, it will be necessary to make the changes listed below in addition to making the tube replacement.

2. Remove R85 (R84 in some sets), a 1.5-k resistor connected between one side of the vertical linearity control and pin 6 of the 6BL7, and in its place install an 820-ohm resistor.

3. Remove R93 (R57 in some sets), a 1-meg resistor connected between pin 4 of the 6BL7 and chassis,

and in its place install a 2.2-meg resistor.

4. Remove *R95* (*R59* in some sets), a 15k-ohm resistor connected between boost B+ and the vertical deflection yoke, and in its place install a 6.8k-ohm 2-watt resistor.

5. Some of the early sets may use a part No. 51X159 vertical output transformer. If this is the case, the vertical output transformer will also have to be changed to part No. 51X156 when the above change is made. The transformer can be identified by the part number stamped on the top or side.

Whenever you encounter the problem of vertical instability on any of the above models, or if there is one of these same models on which you cannot cause the picture to roll both up and then down by varying the vertical hold control from its extreme left-hand position to the extreme right-hand position, the above changes are to be made.

MONTGOMERY WARD Models
25WG- and
35WG-3060, -3066,
-3070, -3071, -3072,
-3073, -3075, -3077,
-3079, -3160, -3170,
-3177, -3180, -3190

Horizontal jitter.

In new television areas, particularly where final transmitter adjustments have not yet been made, an unstable picture, in the form of horizontal jitters, may be encountered in the above models. In most cases, this is caused by a phase shift in the timing circuits of the television transmitter.

The above condition can be corrected by removing the long time constant filter network *C61*, a .22- μ f capacitor, and *R80*, a 33,000-ohm resistor, connected in series from pin 4 of the 6SN7 horizontal oscillator to ground. Simply disconnect at pin 4 and leave the parts in the set as they should be reconnected the next time service is required after the above condition has been remedied.

This network is used to minimize bending at the top of the picture and its removal will increase this tendency to some extent, depending upon the individual chassis.

It would be helpful to call the phase-shift condition to the attention of the transmitter engineer at the station involved, since he may not be aware of it.

MONTGOMERY WARD Models
25WG- and
35WG-3060, -3066,
-3070, -3071, -3072,
-3073, -3075,
-3077, -3079

Interference to broadcast receivers.

Interference to broadcast receivers may be caused by radiation from the horizontal sweep circuit on early models of the above sets using 21-inch picture tubes. To remedy, proceed as follows:

1. Remove the chassis from the cabinet.

2. Remove the lead connected from terminal 3 of the horizontal output transformer to the filament terminal of the 6W4 damper tube. Ground this filament terminal to chassis at the socket.

3. Remove the 6W4 damper tube and in its place install a 6AX4 tube. No changes are necessary other than those listed in step 2.

4. Change the chassis tube layout diagram to indicate that a 6AX4 has been substituted. Immediate breakdown will result if the 6W4 is used in place of a 6AX4 after the circuit changes have been made.

5. Reinstall the chassis in the cabinet.

Make the modifications listed above *only* if a complaint of interference is received.

The changes listed herein have already been incorporated in later production of the above models.

MONTGOMERY WARD Models
25WG- and
35WG-3060, -3066,
-3070, -3071, -3072,
-3073, -3075,
-3077, -3079

Eliminating drive bar.

Due to variations in the characteristics of the 6SN7GTA horizontal oscillator and the 6BQ6GT horizontal output tube, the coupling capacitor C65 between these two tubes is changed in later production from 220 μmf to 200 μmf in order to eliminate the drive bar. This lower value capacitor allows the horizontal drive control to be set at the center of its operating range, instead of at one end which was necessary due to the characteristics of some tubes.

The 200- μmf capacitor to be used for replacement may be obtained by paralleling two 100- μmf universal ceramic capacitors (part No. D6-101).

MONTGOMERY WARD Models
35BR-3158A,
-3167A, -3168A, -3169A

No uhf reception.

If the receiver is "dead" when attempting to view a uhf program, first check the position of the selector switch, then determine whether a signal is being transmitted and check the antenna and lead-in connections before suspecting trouble in the tuner.

Also as a fast check, view the face of the picture tube at minimum contrast or picture control setting and advance the control to maximum and then compare the difference. If there is little or no difference (no snow), check the video detector and i-f amplifiers. If an increase of snow appears at maximum control setting, check the first i-f stage before looking to the tuner for a defect.

If the uhf tuner is not functioning properly, first substitute the oscillator (6AF4) and cascode amplifier (6BQ7A) tubes. Next check the voltages at the uhf power socket or cable connections in the receiver.

If servicing the set with a soldering iron, crystal detector or component parts replacement is necessary, the picture tube must be removed. Removing the picture tube places the majority of the uhf tuner components within easy reach and most of the parts can be serviced. The tuner should not be removed from the chassis when service is required, also caution must be observed not to lay the chassis on the tuner side. Damage to the uhf tuner may result.

Caution: When attempting to service the tuner, do not move or re-

arrange components or mechanical parts as a change in distributed capacitance may result and off-set the alignment. When replacing a component, be sure to obtain the same lead lengths and replace in the same physical position.

MONTGOMERY WARD Models
35BR-3158A,
-3167A, -3168A, -3169A
**Checking uhf oscillator and
mixer (see Fig. 18).**

To determine whether the uhf oscillator section is functioning, a convenient check point has been provided where the oscillator grid current can be measured. To measure the oscillator grid current, place a Simpson model 260 multimeter (or equivalent) on the 100-microamp scale across the 22-ohm resistor *R2*. See part (A) of the figure. A reading

of 10 to 30 microamperes should be obtained if the oscillator is functioning normally.

Both the oscillator and crystal detector can easily be checked by measuring the oscillator injection current. Place a Simpson model 260 multimeter (or equivalent) on the 100-microamp scale across the 22-ohm resistor *R10* at the terminal indicated in part (B) of the figure. A reading of 5 to 40 microamperes should be obtained if both the oscillator and crystal are functioning normally.

Note: The low sides of both resistors mentioned above are grounded.

MONTGOMERY WARD Models
with 6BQ7 tube
in tuner

Failure of 6BQ7.

The 6BQ7 tube, which is used in the tuner, has shown a tendency to

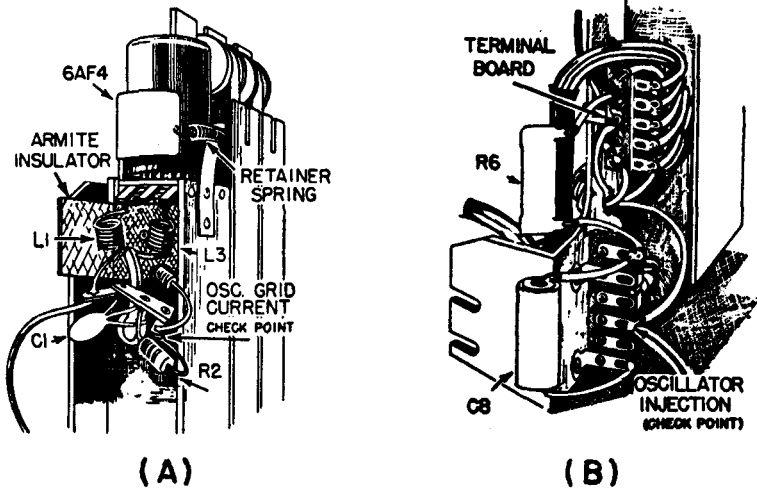

Fig. 18 — Montgomery Ward

fail after a short period of time. The majority of the failures have shown up as an internal shorting and an inability of the tube to satisfactorily amplify the frequencies of all tv channels by the same amount.

As a correction for the above problem, a 6BQ7A tube has been developed to replace the 6BQ7 tube. The 6BQ7A is constructed so as to overcome the deficiencies which have been characteristic of the 6BQ7 tube. The tubes are directly interchangeable. When failure of the 6BQ7 occurs, it should be replaced with a 6BQ7A. This tube is used in later production whenever available.



MOTOROLA Chassis TS-292,
-410 series

Improved blanking.

To increase the blanking pulse at the grid of the picture tube, the following resistor changes, already made in later production, are included:

1. R62, 3,300-ohm resistor connected to pin 2 (grid) of the picture tube, is changed to 1,800 ohms.
2. R63, 1,800-ohm resistor connected to pin 2 of the picture tube is changed to 3,300 ohms.

MOTOROLA Chassis TS-292,
-410 series

Preventing h-v flash-over within picture tube and vertical output tube.

To prevent h-v flash-over in the above tubes, the following changes,

already made in later production, are included:

1. C75, 5,000- μ mf, 2,000-volt capacitor, is added from the picture tube focusing anode (blue lead) to the chassis.
2. C73, 5,000- μ mf capacitor connected to pin 3 (cathode) of the vertical output tube (V13B, 6BH7), is changed to a 2,000-volt unit.

MOTOROLA Chassis TS-292,
-410 series

Providing added protection to focus control (see Fig. 19).

To add protection to the focus control potentiometer, the following changes, already made in later production are included:

1. C75, 5,000- μ mf capacitor is removed.
2. R95, a 100k-ohm, 1-watt resistor, is added between the focus control arm and the blue lead to the picture tube focus anode. (Note: The

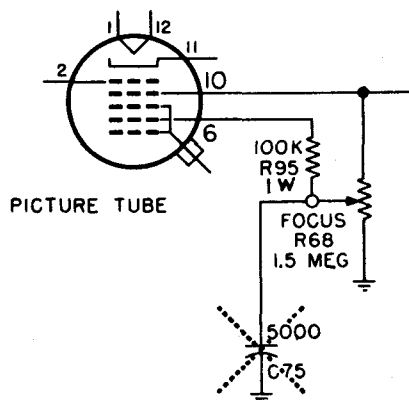

Fig. 19 — Motorola

pin 2 plate of 1st sync clipper) is changed to 1 meg.

MOTOROLA Chassis
TS-292 series

Reducing heater-to-cathode leakage of V10.

To reduce heater-to-cathode leakage of V10, the 1st audio amplifier and phase detector, insert R94 (0.47-ohm, 1/2-watt wirewound resistor) in series with the heaters of V10.

MOTOROLA Chassis
TS-292 series

Eliminating vertical flutter due to line voltage variations.

To eliminate vertical flutter due to the above cause, change C74, 20- μ f capacitor connected between the high side of the vertical linearity control and one side of the vertical size control, to 10 μ f at 450 volts. This change is already made in later production coded B-02.

MOTOROLA Chassis TS-292

Snowy picture.

A snowy picture in the above chassis may be due to the value of R5 changing because of age and heating.

This resistor, a 1,500-ohm value, feeds the plate of the 6BZ7 r-f tube. When this value changes, it causes a drop in plate voltage to about 125 volts, resulting in a snowy picture.

MOTOROLA Chassis TS-292

Loss of horizontal size.

The following conditions may occur in the above chassis: Loss of

horizontal size, accompanied by four white vertical lines or bars on the left side of the raster, plus the fact that varying the horizontal hold control varies the brightness and the size.

The cause is an open capacitor C92, in the capacitor, choke-wound assembly (L24, C92) part No. 24K710751. This assembly is connected between the arm of the horizontal centering control and the red lead of the horizontal deflection coils in the yoke.

MOTOROLA Chassis TS-292

Small raster and extreme horizontal foldover.

A small raster accompanied by extreme horizontal foldover in the above chassis may be caused by an open capacitor C74 (20 μ f) in the cathode circuit of the vertical output section of the 12BH7. To remedy this condition replace the capacitor.

MOTOROLA Chassis TS-402,
-418, -502, -518
-525, -528, -531,
-603, -609

Horizontal pulling.

In the case of horizontal pulling, the horizontal oscillator circuit generally is not responsible for what is suspected to be a horizontal deficiency. The following are some causes of horizontal pulling:

1. *Defective 3rd i-f tube or video detector crystal* in averaging-type age sets resulting in overload condition. To definitely determine (other than by tube or crystal changing), proceed as follows: Connect a 5-megohm potentiometer from the age line to ground. Connect a vtvm across the

video detector load resistor (pin 3 of the test receptacle to ground). With a medium-to-strong signal applied at the antenna terminals, slowly reduce the resistance of the potentiometer until the negative voltage across the detector load reaches a peak. Further reduction of the potentiometer will cause a condition of overload and the detector voltage will fall below the peak. If the peak voltage, as indicated on the meter, is less than 13 volts negative, replace the 3rd i-f tube (6CB6) and/or the video detector crystal. (Area selector switch must be in Local position.)

2. *Defective 3rd i-f tube or video detector crystal* in keyed-agc type sets. To determine, proceed as follows: Short both agc buses to ground. Attach a signal generator to the antenna terminals set to the midfrequency of any channel. Tune the receiver under test to this signal and increase the output of the generator while observing the developed d-c diode voltage with a vtvm. The voltage must increase to a minimum of 13 volts negative. If limiting is observed, replace the crystal diode and/or the last i-f tube.

3. *Grid current* being drawn by one or more tubes in the agc circuit. Negative voltages, as indicated on a vtvm, from pins 1 and 3 (in averaging-type agc sets) of the test receptacle to ground, should normally be equal. Area selector switch must be in the Local position. A good means of checking an i-f agc overload condition in averaging agc systems is to change the area selector switch from Local to Suburban position. If the overload condition is removed or

lessened, you can suspect a defective tuner tube. In keyed-agc type sets either the 1st or 2nd i-f tube may draw grid current. To determine, check the ratio of the i-f agc voltage to the plate voltage of the keyed-agc tube. It should be in the order of 1 to 3.5 volts. If the ratio is lower than this, check these i-f tubes.

4. *Excessive screen current drawn by the 3rd i-f tube.* Check for low screen grid voltage.

5. *Insufficient clipping* in the 1st or 2nd clippers, or unbalanced output from the phase detector. Check for resistors of incorrect value.

6. *Poor high voltage regulation.* This may be caused by a poor picture tube aquadag connection to chassis ground. In this instance, you have complete raster pulling which is observable by reducing width and locking at raster edges. Correction is obvious.

7. Further, in any set, lead dressing may be a factor in the elimination of these troublesome cases. In any dressing that may permit undesirable video or horizontal sync pulses, coupling should be remedied. Leads from the horizontal hold control to the multivibrator tube itself (which are physically far removed in many instances) are subject to this type of coupling. Or, leads from the contrast or brightness controls (which may be in close proximity to the horizontal hold control, since these controls are mounted close together on the control panel) are subject to this same scrutiny and redressing. Use of suitable bypass capacitors at vital points may be of help in removing this coupling. One such case is by adding a

.005- μ f to .01- μ f ceramic capacitor disc from the arm of the brightness control — right at the control — to chassis ground, on those sets that do not have such a bypass, and where the brightness control is in the cathode circuit of the picture tube.

MOTOROLA

Chassis TS-402,
-418, -502, -518
-525, -528, -531,
-603, -609

Fine-line tearing.

Fine-line tearing and multi-line tearing (generally referred to as "scalloping") are problems that, as well as being controlled to a major degree by the efficiency of the horizontal multivibrator circuit itself, are aggravated by the presence, in varying degrees, of external electrical noise, or internally generated spurious horizontal pulses.

The ability of a multivibrator to withstand these disturbances is a direct function of the sine wave amplitude percentage present in the overall waveform. The ratio of sine wave to pulse amplitude should be in the order of one to one.

Should this vary in the order of a greater sine wave to pulse of say 2 to 1, horizontal hunting may occur. Should this vary in the order of a smaller sine wave to pulse of say 1 to 2, fine-line tearing or scalloping (multi-line replacement) may occur. This ratio may be observed on an oscilloscope (using a low capacitance probe) connected to the plate of the oscillator section of the multivibrator.

A second method of determining this ratio is to slowly adjust the horizontal hold control from each end and count the number of slant bars on either side of sync, or locking, just before horizontal locking occurs. This is useable, however, only when you have a strong signal available. You should not have less than two, or more than four bars at this moment. This corresponds within 5 percent to a 1 to 1 sine wave to pulse amplitude ratio.

The sine wave amplitude alone is proportional to the "Q" of the horizontal oscillator coil, the value of the coil shunt capacitor, the value of the plate load resistor, the value of the plate to ground capacitor, and the oscillator tube, 6SN7. It follows that these should be checked and, if defective, replaced to remedy any trouble in this section.

In some cases, damping the horizontal oscillator coil with a resistor, in the order of 22k ohms to 47k ohms will remove horizontal jitter or hunting.

Internally generated spurious horizontal pulses may cause a multivibrator circuit to attempt to lock on these pulses, which are slightly removed, before and after the station sync pulse. They may be observed at the plate of the video amplifier using an oscilloscope.

These pulses may originate in several places in the horizontal deflection system. They are aggravated by conditions of high line voltage with resultant abnormally high voltage and/or weak signals with high set gain.

The pulses may originate from:

1. 1B3 tube, cap or socket
2. Damper tube
3. High voltage transformer
4. Plate connection of horizontal output tube

Generally, they are caused by corona at the above points and, in the case of the damper tube they may arise due to resonance of the leads connected to this tube. The remedy for this condition consists of exercising the usual precautions for preventing and removing corona and inserting 10-microhenry chokes in the plate and cathode leads to the damper tube.

MOTOROLA Chassis TS-402,
-418, -502, -518
-525, -528, -531,
-603, -609

Critical horizontal locking.

Along with many component breakdowns, critical horizontal locking can occur due to the horizontal hold control itself. Where this occurs, check the control for a change in value. Normal use or an accumulation of dirt may cause such a control to increase in value. It is an increase in value that introduces critical locking adjustment. It follows then, that should such sharp adjustment exist, and the control is of normal value, and all other components in the multivibrator are good and normal, the remedy for this sharp adjustment is to reduce the value of the hold control. This may be done by replacement with one of a lower value or by placing a suitable shunt across the existing control.

In some cases, adding an 82k-ohm resistor in series with the arm of the hold control and a 150k-ohm resistor in shunt with the hold control will increase the range considerably.

MOTOROLA Chassis TS-402,
-418, -502, -518
-525, -528, -531,
-603, -609

Servicing horizontal deflection system troubles.

Servicing horizontal deflection system troubles can best be done rapidly by first determining exactly in which circuit the fault lies. This may be done by shorting the grid of the first multivibrator section to ground, and observing the locking action of the multivibrator circuit and control. Where you have tearing, scalloping or critical lock condition and, if after shorting the grid and at least partially locking a picture by means of the hold control, these items are removed, it becomes obvious the trouble is ahead of the multivibrator itself.

The r-f and i-f circuits should then be checked. Otherwise, the fault lies in the multivibrator and its malfunctioning should be checked as indicated above.

To determine if the trouble is before or after the horizontal phase detector, short this same grid to ground. If the sync recovers, then an unbalanced voltage is being fed to this point. A voltmeter connected to the phase detector voltage divider (junction of the two 100k-ohm resistors and ground) will show which side is unbalanced by rotating the horizontal

hold control. It should swing from approximately plus 2 volts to minus 2 volts.

Observance of this isolating procedure should be practiced in diagnosing all such problems.

MOTOROLA Chassis TS-402,
-502, -505, -507,
-524 series

Reducing horizontal shift at varying contrast settings.

To reduce horizontal picture shift as the contrast control setting is changed, the following modifications, already made in later production coded A-02, are made:

1. *R50*, 10,000-ohm resistor connected to sync take-off point in video amplifier plate circuit, is changed to 22,000 ohms.

2. *R49* (15,000 ohms) and *C59* (470 μmf), parallel R-C circuit between *R50* and the sync input coupling capacitor, are shorted out.

MOTOROLA Chassis TS-402,
-502, -505, -507,
-524 series

Reducing horizontal pull in strong signal areas.

R47 (1-meg resistor connected to control grid, pin 2, of video amplifier) is removed from ground and placed in series with a 5,600-ohm resistor to ground. Between the junction of these two resistors and the area selector switch side of *R38* (18,000 ohms), a 180,000-ohm resistor is added. This reduces horizontal pull in Local and Suburban area positions. (Note: These changes are already made in later production chassis coded A-06).

MOTOROLA Chassis TS-402,
-502, -505, -507,
-524 series

Preventing arc-over in picture tube.

C117, 5,000- μmf , 2,000-volt ceramic disc capacitor (part No. 21R120093), is added between the control grid (green) lead of the picture tube and ground to prevent arc-over in the picture tube. This change is already made in later production coded B-02.

MOTOROLA Chassis TS-402,
-502, -505, -507,
-524 series

Preventing video from radiating into horizontal hold control.

C118, 5,000- μmf , 450-v ceramic disc bypass capacitor, is added between the junction of *R89* (brightness control centertap) and *R88* (100 k) to prevent the video from radiating to the horizontal hold control. This change is already made in later production coded B-03.

MOTOROLA Chassis TS-402,
-502, -505, -507,
-524 series

Increasing sensitivity on high channels.

C12, 470- μmf feed-through capacitor connected to pin 7 of the r-f amplifier, is changed to a 470- μmf ceramic disc type which is grounded to r-f shield to increase sensitivity on the high channels. The two resistors *R4* (390 k) and *R5* (470 k), which used the feed-through capacitor as a tie point, are moved to pin 7 of the

r-f amplifier. This change is already made in later production coded B-05.

MOTOROLA Chassis TS-402,
-502, -505, -507,
-524 series

Increasing horizontal sweep.

C111, 56- μmf , 3,000-volt capacitor connected across the damper tube, is changed to 100 μmf at 3,000 volts in order to increase the horizontal sweep. This change is already made in later production coded B-08.

MOTOROLA Chassis TS-402,
-502, -505, -507,
-524 series

Improving contrast-to-brightness ratio.

To improve contrast-to-brightness ratio, the following changes, already made in later production coded B-06, are incorporated:

1. *R80*, 1,800-ohm resistor connected to pin 2 of the picture tube, is shorted out. The resistor itself is removed.

2. *R81*, 3,300-ohm resistor connected between pin 2 of the picture tube and ground, is changed to 5,600 ohms.

3. *R112*, 470k-ohm resistor, is added from the junction of 4.5-mc trap (*L29*) and peaking coil *L30* (both in plate circuit of video amplifier) to the high side of *R89*, brightness control.

4. B+ lead is removed from the high side of *R89*.

5. *C118*, 5,000- μmf , 450-volt capacitor, is added between the high side of the brightness control and ground.

6. The picture tube control grid (green lead) is connected to the centertap of the brightness control.

7. *C117*, 5,000- μmf , 2,000-volt capacitor, is coupled between the centertap of the brightness control and the junction of *C92* (.047 μf), *C93* (.047 μf) and *R81* (5,600-ohm resistor indicated in step 2 above). These three components are in the plate circuit of the vertical blocking oscillator.

8. *R88*, 100k-ohm resistor, is placed in parallel with *C60*, 0.1- μf video coupling capacitor to cathode (pin 11) of the picture tube.

9. *R113*, 220k-ohm resistor, is added between the cathode of the picture tube (pin 11, yellow lead) and ground.

MOTOROLA Chassis TS-402,
-502, -505, -507,
-518, -524

Vertical nonlinearity at high contrast.

Vertical nonlinearity may be caused by the presence of video information in the grid circuit of the vertical amplifier of some of the subject sets under high contrast settings.

To eliminate this condition where it is found, it is recommended that the technician try changing the coupling capacitor from 5,000 μmf to 1,500 μmf . In some chassis, this is *C93*; in others it is *C117*.

MOTOROLA Chassis TS-402,
-502, -505

Picture flashing and channel 6 oscillation.

The above conditions may be due to improper routing and placement of the balun line, where it is close to the top of the set. Try changing the position of this line to effect improvement.

MOTOROLA Chassis
TS-410 series

Improving tone.

To improve audio tone, the following changes, already made in later production coded A-01, are included:

1. *C61*, connected between control grid (pin 5) and cathode (pin 8) of the audio output tube (*V11*, 25L6), is changed from .005 μf to .01 μf .

2. *C102*, .02- μf capacitor, is shunted across the primary of the audio output transformer.

MOTOROLA Chassis
TS-410 series

Reducing horizontal overdrive.

To reduce horizontal overdrive and foldover, the following changes, already included in later production coded A-05, are made:

1. *R82*, 4,700-ohm peaking resistor in output circuit of horizontal oscillator, is changed to 6,800 ohms.

2. *R85*, 4,700-ohm plate dropping resistor of the horizontal oscillator connected to the damper plate, is changed to 5,600 ohms.

3. *C80*, .002- μf capacitor connected to pin 5 of the phase detector (*V10B*, 6SN7), is changed to a 4,700- μmf , 600-volt capacitor.

MOTOROLA Chassis
TS-410 series

Improving horizontal centering.

To improve horizontal centering, the following changes, already included in later production coded A-12, are made:

1. *C92*, .15- μf capacitor connected between the arm of the horizontal centering control and the red lead of the horizontal deflection windings, is removed.

2. *R100*, 18-ohm, 10%, 1/2-watt resistor, is connected between lugs 2 and 3 of *T11*, horizontal output transformer.

3. Deflection coil red lead is soldered to lug 3 of *T11*.

MOTOROLA Chassis
TS-410 series

Loss of hold and no sound.

Loss of vertical and horizontal hold and no sound in the above chassis may be caused by a shorted *C95A* electrolytic capacitor in the power supply. This capacitor, connected between the 250-volt and 150-volt bus, is a 200- μf unit.

With *C95A* shorted, the 250-volt bus voltage is then applied to the 150-volt bus. This results in improper operation of the first clipper, with the result that there are no sync pulses to provide locking and at the same time this puts over 200 volts on the cathode of the audio output tube, cutting it off and thus no sound is produced.

MOTOROLA Chassis TS-410
High voltage arcing.

High voltage arcing in the above chassis may be due to poor lead dress around the high voltage transformer. The B+ and screen leads running

from the yoke plug to the 25BQ6 socket and the B+ electrolytic may be laying next to the damper cathode. Also the damper cathode socket lugs may be pushed flat against the socket near the chassis. These conditions are possible sources of trouble.

To remedy, dress all leads $\frac{1}{2}$ -inch away from the damper socket, also inspect the damper socket lugs.

MOTOROLA Chassis TS-418,
-518 series
Reducing grid current of picture tube at maximum brightness.

To decrease grid current at maximum brightness, a 2.2-meg resistor is added between the grid of the picture tube and the center arm of the brightness control. This change is already made in later production coded B-02.

MOTOROLA Chassis TS-502,
-505, -507,
-524 series
Improving horizontal linearity and increasing high voltage.

The following changes, already made in later production coded B-01, speed retrace, improve horizontal linearity and increase the high voltage:

1. *T8*, horizontal output transformer, is changed to newer type part No. 24K732746 in TS-502, -507 and -524 series and to newer type part No. 24K732747 in VTS-505 only.

2. *R102*, horizontal hold control, is changed from 150k ohms with a 40k-ohm stop to a 200k-ohm control with a 50k-ohm stop.

3. *R86*, 470-ohm resistor connected between pin 4 (screen) of the horizontal output tube and pin 7 of the yoke receptacle, is changed to 680 ohms, 1 watt.

4. *R103*, 100k-ohm resistor connected to pin 5 (plate) of the horizontal oscillator tube, is changed to a 68k-ohm resistor.

5. *R104*, 6,800-ohm peaking resistor in output circuit of the horizontal oscillator, is changed to a 4,700-ohm resistor.

6. *C108*, 680- $\mu\mu\text{f}$ sawtooth forming capacitor connected between the high side of the peaking resistor and the plate (pin 5) of the horizontal oscillator, is changed to 390- $\mu\mu\text{f}$ at 500 volts.

7. *C111*, capacitor across damping diode, is changed to 56 $\mu\mu\text{f}$ at 3,000 volts.

MOTOROLA Chassis TS-502,
524
Beat interference on Channel 8.

Fringe area reception on channel 8 may have a beat interference on some of the above chassis. The interference may be tuned out by using the fine tuning and it may be worse just off the video carrier.

This beat interference is a result of the fourth harmonic of the i.f. beating against the video of channel 8. The video i.f. is 45.75 mc of which 183 mc is the fourth harmonic. The channel 8 video carrier is 181.25 mc and the sound carrier is 185.75 mc. You will note that the beat interference signal of 183 mc falls between the video and audio carriers.

The redressing of the antenna lead within the tv cabinet will result in a cure of this fringe area beat interference problem on Channel 8. Rerouting this lead across the inside top of the cabinet and down the inside front is most effective.

Caution: This transmission line from the antenna terminal to tuner is a special impedance matching section, and should not be cut or spliced or replaced with a normal type of 300-ohm transmission line.

MOTOROLA Chassis TS-502
Insufficient picture size.

In the above chassis, the horizontal size control moves the high voltage transformer core into the windings. A core travel plate is attached to the threaded end of the horizontal size control shaft and the transformer core. Should there be insufficient picture size, try increasing the travel of the core into the windings. This can be done by bending the core travel plate upward slightly.

MOTOROLA Chassis TS-502
Removing static charge on metal bezel.

R111 (470 k) is changed to 2.2 meg to eliminate any static charge that may remain on the metal bezel when the set is turned off. This change affects only the PTS-502 chassis. The resistor is located between the secondary of the audio output transformer and ground. This change is already made in later production coded B-07.

MOTOROLA Chassis TS-525 series
Improving i-f response.

To improve i-f response, the following changes, already made in later production coded A-01, are included:

1. *C38*, 470- μmf capacitor connected between cathode (pin 2) and ground of the 2nd i-f stage, is changed to .001 μf .

2. *C40*, 560- μmf capacitor connected between screen (pin 6) and ground of the 2nd i-f stage, is moved to a direct chassis ground.

MOTOROLA Chassis TS-525 series
Improved horizontal centering and reduced neck shadow.

To aid the magnetic centering device in horizontal centering and reduce neck shadows, a nonadjustable horizontal centering circuit is added as follows:

1. *C106* (.1- μf capacitor connected between terminals 4 and 5 of *T13*, horizontal output transformer, and pin 4 of the yoke receptacle) is replaced with linearity coil *L44* (part No. 24A731609) to provide a d-c path through the horizontal deflection yoke.

2. Connection between lugs 4 and 5 of the horizontal output transformer (*T13*) is removed and an 18-ohm resistor is inserted between lugs 4 and 5 to force current through yoke.

3. Leads of *L41* (r-f choke to the damper cathode) and *R83* (150k-ohm resistor to the phase detector) connect to lug 4 of the output transformer; the lead of *L44* (added above) connects to lug 5.

MOTOROLA Chassis
TS-525 series
Improving sync range at high contrast.

R66 (4.7-meg grid-to-ground resistor of 1st sync separator) is changed to 1.5 meg and ground end reconnected to cathode (pin 3) of V13 (sync separator) to improve sync range at high contrast levels. This change is already included in later production coded A-03.

MOTOROLA Chassis
TS-602 series
Providing greater safety factor.

The following changes, some or all of which are already made in later production, will provide for a greater safety factor in the operation of the circuits:

1. R108, in bootstrap circuit to the low end of the vertical size control, is changed from 82,000 ohms at 1/2 watt to 100,000 ohms at 1 watt.

2. R124, 5,600-ohm, 2-watt resistor connected to screen of the horizontal output tube, is changed to a 7,500-ohm, 5-watt resistor.

3. R137, 5-ohm, 5-watt special plug-in wirewound resistor in a-c line to selenium rectifiers, is changed to a 7.5-ohm, 5-watt unit of the same type.

4. Selenium rectifiers CR2 and CR3 are both changed from 450-ma units to 500-ma units. In addition, selenium rectifier CR4, 100-ma unit in parallel with CR3, is removed.

MOTOROLA Chassis
TS-602 series
Supplying higher B+ for uhf tuner.

To supply a higher B+ voltage for the uhf tuner, the following changes, already made in later production coded A-01, are included:

1. R1, 2,700-ohm resistor connected between the B+ terminal for the uhf tuner and lug 7, wafer SIC of channel selector switch, is changed to 1,800 ohms.

2. R2, 2,700-ohm resistor connected between B++ terminal and lug 8, wafer SIC of channel selector switch, is changed to 2,200 ohms.

MOTOROLA Chassis
TS-602 series
Improving vertical linearity and eliminating vertical foldover.

The following changes, already made in later production, are included to improve vertical linearity and eliminate vertical foldover:

1. R115, 22,000-ohm peaking resistor in output circuit of vertical blocking oscillator, is changed to 10,000 ohms.

2. In case this change results in foldover, change R115 to 15,000 ohms.

MOTOROLA Chassis
TS-602 series
Preventing picture pulling during overmodulation.

To prevent the picture from pulling during overmodulation, R56, 15k-ohm resistor connected between pin 6 of 1st sync amplifier V14B (12AU7) and the input circuit of sync separator and noise gate tube V15 (6CS6), is changed to 1,500 ohms. This change is already made in later production coded A-01.

MOTOROLA Chassis
TS-602 series
Increasing contrast reserve.

To increase contrast reserve, R82 (10,000-ohm resistor connected between pin 8 cathode of V11B., 12AU7 pulsed agc tube B+ bus) is changed to 8,200 ohms. This change is already made in later production coded A-06.

MOTOROLA Chassis
TS-602 series
Centering range of vertical hold control.

To center the range of the vertical hold control, the following change already incorporated in later production coded A-08, is made: R104 (220,000-ohm resistor connected to high side of vertical hold control) is changed to a 270,000-ohm resistor.

MOTOROLA Chassis TS-602
Removing Channel 6 tweet.

To tune out a tweet on Channel 6 in strong signal areas, mount trap TK-30 on the tuner and adjust it to approximately 87.75 mc.

MOTOROLA Chassis TS-602
Horizontal pulling.

In the event of horizontal pulling in the above chassis, check the value of R74, grid resistor of 6CS6 noise gate tube. This should measure 820k ohms. If it does not, replace the resistor.

MOTOROLA Chassis TS-602
with 24-, 27-inch
picture tube

Brightness control has little effect.

Brightness control may have little effect in the above chassis. This

may be caused by a shorted .01- μ f, 600-v capacitor C109 to the grid of the picture tube. This permits B+ to ride the grid, hence the picture is either bright or brighter. To remedy replace the capacitor.

MOTOROLA Chassis TS-602
with 24-, 27-inch
picture tube

Focus drift.

Focus drift in the above chassis may be caused by the focus coil current warming up the focus coil. To remedy, set the focus after the receiver has warmed up a few minutes.

MOTOROLA Models with
plastic grill cloth
Warping or sagging plastic grill cloth.

To remedy a condition of warping or sagging of the plastic grill cloth:

1. A 250-watt, industrial infra red ray lamp with reflector is necessary.
2. Keep the lamp about 4 to 6 inches from the cloth .
3. Depending upon the amount of the sagging, play the heat from the lamp against the grill cloth for 45 to 60 seconds.
4. Move lamp around while applying heat to prevent melting of plastic grill cloth.

MOTOROLA Split-sound
chassis with uhf
converter

Loud hum on uhf.

Loud hum may occur when used on uhf with TC-101 converter. The cause is that resistor filtering is inadequate when the TC-101 is used

FILE EARS TO ENGAGE SLOTS
IN MID-FREQUENCY BUSHING.

SECTION OF CAR RADIO
ANTENNA ROD
(APPROX. 5/16" OD - 1/4" ID)

TUBE, OPEN AT BOTH
ENDS, FOR THE INSULATED
TUNING ROD TO HOLD
OR ADJUST LOW FREQUENCY
SLUG.

3" (APPROX.)

INSULATED KNOB
TO FIT—SUCH AS
PART NO. 36K478249

Fig. 21 — Motorola

with the pre-intercarrier sets using separate sound i-f's.

To remedy, substitute a 30-henry choke in place of the 470-ohm power supply filter resistor *R12* in the uhf converter.

MOTOROLA

Chassis with
TC-101 uhf
converter

Tuning tool for peaking adjustments (see Fig. 21).

The convenient tool illustrated in the figure will facilitate peaking adjustments on the above uhf converter or its built-in equivalent. Complete instructions are given on the figure.

MOTOROLA

Chassis with
TC-101 uhf
converter

Providing uhf signal source from uhf converter.

To provide a uhf signal source prior to the actual on-air date of a prospective uhf station for service

and checking purposes, the following is offered:

Conversion of normally operating TC-101 uhf converter to a uhf signal generator.

1. The modification consists of connecting the input of the cascode stage of amplification to the normal vhf input terminals and connecting the crystal mixer to the plate output circuit of the cascode amplifier. A uhf signal will then be available at the uhf antenna terminals on the back of the converter.

2. In order to place the unit into operation, the off-vhf-uhf switch (*SI*) must be switched to the uhf position. A vhf signal in the frequency range of 76-88 megacycles is applied to the vhf input terminals. This vhf signal is amplified and mixed with the uhf oscillator signal and the resultant uhf signal is available at the uhf output terminals.

3. A vhf television signal on channel 5 or 6 can be applied to the vhf input terminals and a uhf television signal will be available at the uhf

antenna terminals, the frequency of which is determined by the adjustment of the uhf oscillator. Uhf tuners can then be checked in areas where either proper equipment or a uhf signal is not available.

4. The details of the modification are as follows:

- (a) Disconnect grid end of *C5* (1,000- $\mu\mu\text{f}$ capacitor between crystal mixer and *L4* grid input coil) and reconnect to junction of *C15* (5,000 $\mu\mu\text{f}$) and *L12* (tapped impedance matching coil) in the plate output circuit of the cascode amplifier.
- (b) Install impedance matching coil (part No. 24A790033) on present terminal strip containing *C6*, (1 $\mu\mu\text{f}$) *R5*, (47 k) *L3*, (black-dot compensating coil) etc. (Note: These components are in the input circuit of the cascode amplifier.) One end of the coil can be connected to the spare lug at the bottom of the terminal strip. Centertap of the coil can be grounded at the ground lug of the terminal strip. The other end of the coil is connected to the junction of *L4*, *R5* and *C6*.
- (c) Remove the piece of 300-ohm ribbon connected to terminals 8 and 12 of *S1*.
- (d) Remove the vhf input 300-ohm ribbon from *S1* and reconnect through 5,000- $\mu\mu\text{f}$ ceramic capacitors (part No. 21R115312) to the ends of

the impedance matching coil previously installed.

5. After the above modifications have been completed, the uhf antenna terminal strip on the back of the converter becomes the uhf output terminal and the vhf antenna strip becomes the vhf input terminal.

MOTOROLA

All chassis

Barkhausen oscillations.

The effect of Barkhausen oscillation on a tv screen is an erratic vertical black line or figure usually near the right side of the screen. This figure will travel up or down as the vertical hold control is adjusted and will disappear or change form on some channels. A strong tv signal will usually eliminate it or cause it to reverse phase and become a white pattern.

Barkhausen oscillation is caused in the screen circuit of the horizontal output tube where an ultra high frequency oscillation is set up. These frequencies and their harmonics are radiated and picked up in the tuner which passes then through the set and into the picture tube. The amplitude of the signal is usually so weak that a strong tv signal overrides them. Also, a strong tv signal reduces the sensitivity of the tuner and i-f strip by the developed agc voltage and further reduces the Barkhausen oscillation effect. There are several methods for eliminating Barkhausen oscillation as follows:

1. In some sets, certain settings of the horizontal width control can encourage Barkhausen oscillation. These are the models where the width con-

trol changes the air gap in the horizontal oscillator core. A slight readjustment of the control will sometimes eliminate the oscillation.

2. Certain horizontal output tubes are more subject to Barkhausen oscillation than others and changing the tube may eliminate the trouble. After changing the tube, the set should be checked for some time and on different channels as the oscillation may reappear.

3. Placing a magnetic field through the horizontal output tube will kill the oscillations or change them to a frequency outside the range of the tuner. A spring-type ion trap clipped around the tube and adjusted will usually serve the purpose.

4. In stubborn cases, carbon resistors in the order of a few hundred ohms can be placed in the control grid and/or the screen circuit of the horizontal output tube. The ohmic value of these resistors should be kept as low as possible in order to prevent lowering the grid drive or screen voltage excessively. One end of the resistors should be soldered directly to the screen or control grid socket pin and the other end to the circuit that previously went to the pin. Lowering the screen voltage does no harm as long as the picture width is adequate.

MOTOROLA All chassis
Audible 15-kc whistle.

Frequently, a very high pitched whistle at the horizontal sweep frequency occurs in the horizontal output transformer or sometimes in the horizontal output tube itself. This is

usually caused by a loose turn of wire or some part of the circuit that is mechanically resonant to that frequency. This frequency of sound is outside the hearing range of many people but very objectionable to others.

In some horizontal output transformers, a slight readjustment of the horizontal width control will eliminate the trouble. High voltage insulating compound generously poured between the core and the windings of some transformers will often kill the sound. Sometimes the trouble can be eliminated by changing the horizontal output tube itself. In some types of horizontal output transformers that do not use the variable air gap type core, the sound can sometimes be eliminated by slightly loosening or tightening the core clamping screws. Care must be used in tightening these screws however, as it is possible to break the powdered iron core.

MOTOROLA All chassis
Amateur Interference on channel 10 (see Fig. 22).

Television interference from 2-meter amateur transmitters may occur on channel 10, especially in older model tv sets. The method usually used to improve tv reception in this case, is to use a quarter-wave open-end stub at the antenna terminals of the tv set.

Since the cut-and-try method of obtaining the correct length of the stub is not too effective in actual practice, a means of tuning the open-end quarter-wave stub is the logical answer to the problem. The sketches il-

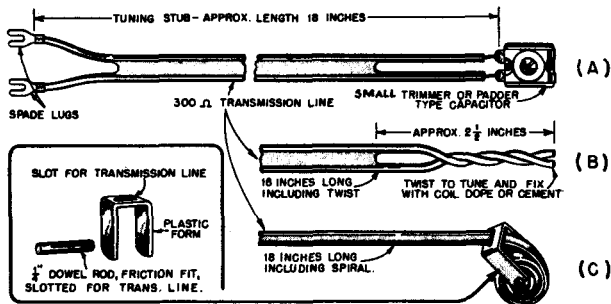

Fig. 22 — Motorola

illustrate these methods of accurately tuning the stubs for optimum performance.

Open quarter-wave stubs and shorted half-wave stubs have been and are being used for "suck-out" of other interfering frequencies. However, in multichannel areas some peculiar attenuation problems on other channels have resulted which in turn requires switching to remove and insert the stub or stubs. So proceed with caution and double check where multistation areas are involved.



MUNTZ Chassis 17B2, 17B6, 17B8

Reducing effect of contrast control on sound i-f circuit

To reduce the effect of the contrast control on the sound i-f circuit, capacitor *C71* (270 $\mu\mu\text{f}$, 500 volts tubular ceramic) is added between the cathode (pin 2) of *V10*, the 6CB6 video amplifier and ground. This

change is already made in later production.

MUNTZ Chassis 17B8
Improving stability of horizontal afc.

To improve the stability of the horizontal afc circuit, capacitor *C63* (.01- $\mu\mu\text{f}$, 600-volt unit connected between terminals *C* and *D* of horizontal oscillator transformer *T6*) is changed to a molded paper capacitor. This change is already made in later production run 6.

MUNTZ Chassis 17B8
Improved tuner isolation.

For better isolation of the tuner from the i-f circuits, a 4,700-ohm, 10%, 1/2-watt resistor (*R10*) is added in series with the white agc lead to the tuner. This resistor is located on the i-f panel assembly. This change is already made in later production run 6.

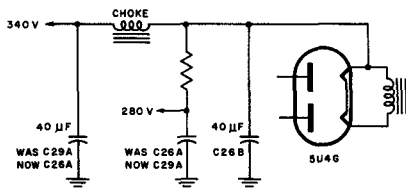

Fig. 23 — Muntz

MUNTZ Chassis 17B8
Reducing coupling between electrolytic capacitors
 (see Fig. 23).

To reduce coupling effects between sections of the electrolytic capacitors, the wiring of *C26A* and *C29A* is transposed as shown in the illustration.

MUNTZ Chassis 17B8
Minimizing neck shadow.

To minimize neck shadow at the left side of the picture and to correct centering of the picture, the 27-ohm, 2-watt resistor (*R81*) connected to terminals 5 and 6 of the horizontal output transformer should be lowered in value. A 120-ohm, 1/2-watt resistor connected in parallel with the 27-ohm resistor is recommended as this reduces the value of the resistance to approximately 22 ohms. However, the value of the resistor may be varied in accordance with the centering and shadow problem.

Caution: Before doing the above adjustment, check to see that all picture tube adjustments are properly completed.

MUNTZ Chassis 17B8
Reducing audio buzz.

In initial production, buzz may be heard in the audio output due to pulse radiation of the vertical output circuit. Placing a metal shield (part No. MP-0487) between the 6AV5GT vertical output tube and the 6W6GT audio output tube, will reduce the pulse pickup and the buzz will be inaudible.

MUNTZ Chassis 17B8
Minimizing component failure.

The following changes already included in later production, are made to minimize component failure:

1. Capacitor *C60* (connected between the pin 1 grid of the horizontal oscillator and the horizontal range control) is changed from a mica 68- μmf , 10%, 500-volt capacitor to a mica 68- μmf , 10%, 1,000-volt capacitor.

2. Capacitor *C64* (connected between terminal *D* of the horizontal oscillator transformer and horizontal drive control) is changed from a tubular ceramic 1,000- μmf , 20%, 500-volt capacitor to a tubular ceramic 1,000- μmf , $\pm 20\%$, 1,000-volt unit.

3. Capacitor *C62* (connected between the pin 4 grid of the horizontal oscillator and terminal *F* of the horizontal oscillator transformer) is changed from a tubular ceramic 180- μmf , $\pm 10\%$, 500-volt, -N330 capacitor to a tubular ceramic Durez insulated 180- μmf , $\pm 10\%$, 500-volt, -N330 capacitor.

MUNTZ Chassis 17B8
Allowing use of various makes of 6CD6's.

The following changes, already included in later production, are

made to allow for the use of various makes of 6CD6 tubes. The two replacements must be made simultaneously.

1. Capacitor *C68* (connected between terminals 1 and 2 of the horizontal output transformer) is changed from .01 μf , $\pm 20\%$, 600 volts to .002 μf , $\pm 20\%$, 600 volts.

2. Resistors *R66* (connected to pin 3 cathode of the horizontal oscillator) and *R71* (connected between terminal *D* of the horizontal oscillator transformer and +325 volts) are changed from 100 k, 10%, 1/2 watt and 82k, 10%, 1 watt to 82k, 10%, 1 watt and 68k, 10%, 1 watt respectively.

MUNTZ All chassis
Preventing vertical instability and signal overload
(see Fig. 24).

Strong ghosts and strong overload signals can double or even triple trigger the vertical oscillator and produce vertical roll. When this condition exists, a 20-db H-pad between the antenna lead-in and the antenna terminal post at the rear of the chassis will usually eliminate the trigger-

ing condition, thus making the circuits stable. Adjust the vertical hold control to a point where the picture will not roll, regardless of where the contrast control is moved; this provides a stable adjustment.

Using the table shown with the figure will save the work of solving the equations to arrive at the required answers. Selection of the proper pad depends upon the signal-to-noise ratio in a given location.

PACIFIC MERCURY Chassis
 150, 200-series

Fuse replacement.

When replacing the 1/4-amp, B+ bus fuse in the field, it is recommended that a 1/4-amp Slow-Blow type 3AG (part No. PMA-95002-4) be used.

PACIFIC MERCURY Chassis
 150, 200-series

Reducing vertical bounce due to sudden line voltage change.

To reduce vertical bounce caused by interference from household elec-

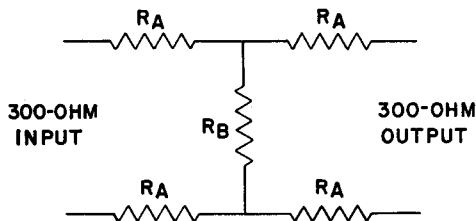

DB	R_A	R_B
5.0	47	510
10.0	82	220
16.0	120	120
20.0	120	62
25.0	150	36
30.0	150	22

Fig. 24 — Muntz

trical appliances, such as refrigerators, etc., change electrolytic capacitor C43 (20- μ f unit connected to junction of R52, 270k, and R54 47k, in 450-volt bus to plate of vertical oscillator) to an 8- μ f, 525-volt electrolytic (part No. PMA-42024). This change is already made in later production beginning with units having serial No. 172,300.

PACIFIC MERCURY Chassis
150, 200-series
Static voltage flashes.

Static voltage flashes may be observed in some receivers due to the construction of the high voltage transformer T9. These flashes will appear across the face of the picture as straight white lines and will be most evident when the set is jarred, due to heavy traffic in a nearby street, movement of furniture within the room, or similar circumstances. In general, the flashes will not be accompanied by audible arcing.

High voltage transformers bearing manufacturer's No. 198340-series are constructed with a Tinnerman nut on the long bolt through the center of the transformer used to hold the core and the terminal strip together. Although this bolt and nut do not come in contact with any part of the high voltage circuit, they can build up a static charge since they are metallic and within a strong field. This static charge arcs from the nut to the metal trap door on the bottom of the cabinet, most often when the set is vibrated or jarred. At that instant the flashes occur, appearing not unlike the effect caused by the movement of

an antenna that has a loose connection.

The Tinnerman nut is covered with a small strip of vinyl tape in later production, to insulate it and prevent its discharging static voltage to the metal trap door. If flashes are observed in sets in the field under the circumstances described above, the serviceman should check, and provide if necessary, such insulation. This may be accomplished through the trap door. The chassis does not have to be removed from the cabinet.

PACIFIC MERCURY Chassis 150,
200-series
Reducing ringing (see Fig. 25).

In order to reduce or eliminate ringing, a new yoke assembly (part No. PMB-97326) is used in later production beginning with the unit having the serial No. 162,000. The ringing (vertical bars on the left side of the raster) has its source in the high voltage transformer and may be due to several factors in the transformer-damper-yoke circuit.

Plug connections for the new yoke are unchanged except that the orange lead is to terminal 7 instead of 5 on the high voltage transformer (T9). C19, the 100- μ f capacitor between terminals 7 and 3 of the high voltage transformer is no longer used. See part (A) of the figure.

Service Change In the Field:

An anti-ringing coil (part No. PMA-52062) has been designed to effectively minimize ringing for those sets produced before the new yoke assembly change. The coil will seldom be required since, in most instances,

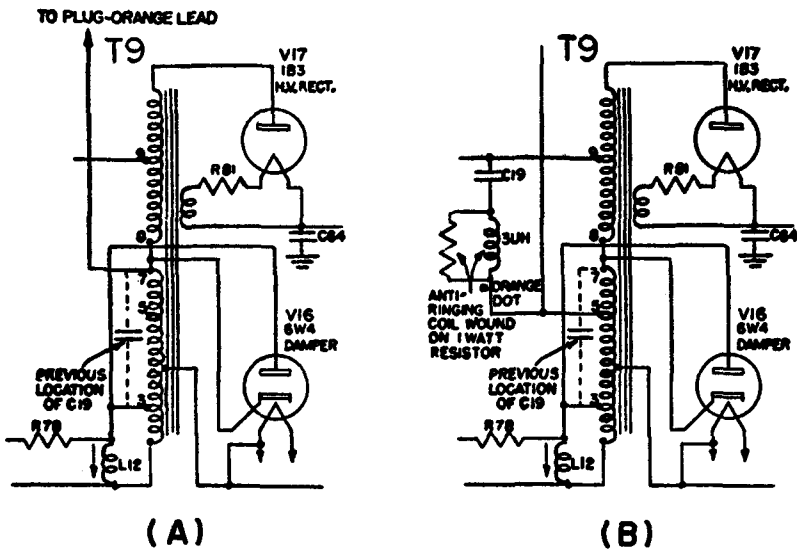

Fig. 25 — Pacific Mercury

ringing is not of objectionable intensity and its use should be restricted only to those cases where a customer's complaint actually exists.

Installation is as follows (see part B of the figure):

1. Remove $C19$, the 100- μf capacitor between terminals 7 and 3 of the high voltage transformer, $T9$.

2. Connect the orange-dot end of the anti-ringing coil to terminal 5 of $T9$.

3. Connect the other end of the coil, through $C19$, to terminal 9.

4. Be sure the solder joint between the coil and the capacitor is smooth and round. Dress the coil and the capacitor close to the transformer and as far as possible from the chassis to avoid corona.

PACIFIC MERCURY

Chassis
150-series

Adjacent channel interference (see Fig. 26).

Adjacent channel sound interference is identified by sound bars in the picture that cannot be eliminated by correct tuning. These bars do not vary with the sound to which the receiver is tuned. This type of interference is caused by a strong local station on the adjacent channel below the desired station. Adjacent channel picture interference is identified by moving ghost pictures in the background from the channel above the desired station.

Two basic methods have been developed for reducing or eliminating adjacent channel interference in the above chassis:

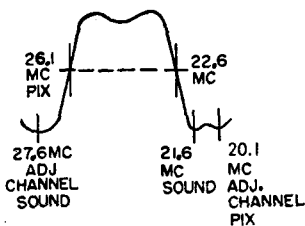
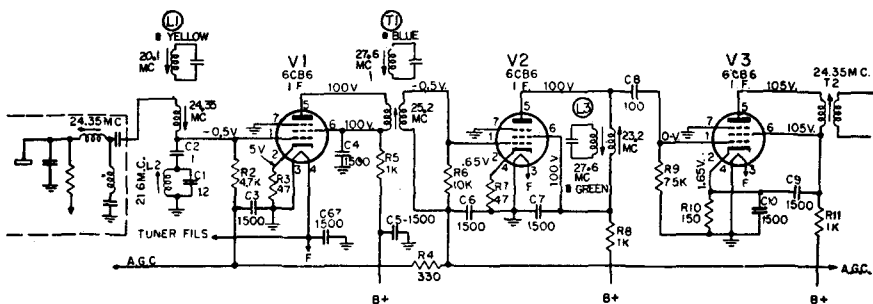

Fig. 26 — Pacific Mercury

Method 1 — attaching appropriate traps on the i-f coils; **Method 2** — replacing original i-f coils with new ones that have built-in traps. The method to be used will depend on the amount of interference present. Replacement of the coils with ones containing built-in traps is recommended when the interference is very strong. If method (1) is employed, the traps should be used in one of the following combinations, again depending on the amount of interference encountered.

1. A single 27.6-mc adjacent channel sound trap (part No. PMA-52054, black color dot).

2. Two 27.6-mc adjacent channel sound traps.

3. One adjacent channel sound trap and one 20.1-mc adjacent chan-

nel picture trap (part No. PMA-52080, white color dot).

Method 1 — Installation and Adjustment of Traps on Original Coils. (Note: Be sure i-f strip is properly aligned.)

1. Feed 7.5-mc sweep width signal at approximately 24.35-mc with a 27.6-mc marker to the i-f strip.

2. Slip 27.6-mc trap over i-f input coil L1 at bottom of chassis.

3. Adjust trap tuning slug so that 27.6-mc marker and trap suck-out coincide on the response viewed on a scope across the video detector load.

4. Make a firm connection between trap and coil but do not couple to the extent that bandpass is narrowed to an objectionable degree.

5. Readjust trap for coincidence of marker and suck-out.

6. Realign i.f. for proper response.

If two 27.6-mc traps are to be used, install the first trap as indicated above and repeat adjustments for second trap which is slipped over interstage coil *L3* between 2nd and 3rd i-f.

Traps may be installed in the field without the use of test equipment as follows: Select a weak station where interference is strong. Slip the required traps over appropriate coils and adjust for the best elimination of interference. Make a firm connection between trap and coils but do not couple to the extent that picture is materially impaired. Alternately check weak and strong channels and make final adjustments for best compromise between elimination of interference and good picture quality.

Method 2 — Replacing Original I-F Coils With New Ones With Built-in Traps. (Note: Replacement of the 3 coils requires i-f alignment test equipment.)

The set of three coils (part No. PMA-97322) are:

1. A single-winding 24.35-mc coil with a 20.1-mc trap and a 56- μmf capacitor and yellow color dot on trap end. Replaces i-f input coil, *L1*.

2. A 25.2-mc bifilar with 27.6-mc trap and a 39- μmf capacitor and blue color dot on trap end. Replaces interstage bifilar between 1st and 2nd i-f, *T1*.

3. A single-winding 23.2-mc coil with 27.6-mc trap and a 39- μmf capacitor and green color dot on trap end. Replaces interstage coil between 2nd and 3rd i-f, *L3*.

Replace original coils with new one. End opposite color dot goes in-

to mounting hole in chassis, locating tab on Palnut must lock into keyhole on chassis, coil must be set deep enough to spring retaining prongs on top of chassis. Terminals will be in the same relative position as on original coil, connections will be the same as on original coils. Bifilar connections are: Bright lead near color dot to pin 5, *V1*; bright lead near mounting end to pin 6, *V1*; dark lead near color dot to pin 1, *V2*; and dark lead near mounting end to tiepoint on agc. After the coils are installed, i-f alignment and trap adjustment are required. The coils and traps are set at the factory. Little adjustment should be necessary on installation. Avoid tightening slugs to the extent that inductance on opposite end is affected.

1. Align i-f strip in the regular manner.

2. With coils properly aligned, set marker generator to 20.1-mc and adjust trap on *L1* (yellow color dot) so that marker and trap suck-out coincide.

3. Set marker generator to 27.6 mc and adjust traps on *T1* (blue color dot) and *L3* (green color dot) so that marker and traps suck-out coincide.

4. Touch up i-f coils, if necessary, to obtain close approximation of the response curve shown.

PACIFIC MERCURY

Chassis
150-series

Reducing 4.5-mc Interference.

A 4.5-mc beat in the picture that cannot be eliminated by the proper tuning of *L2* (21.6-mc trap in 1st i-f grid circuit) and *L8* (4.5-mc trap in

plate circuit of video amplifier) may be the result of an unwanted resonant circuit developing in the tuner leads. In some cases, the tuner agc and 120-volt B+ leads are of such lengths that, in combination with stray capacitance, a resonant circuit is created, interacting with the trapping effect of *L2-C1*.

If difficulty is encountered, in the elimination of 4.5-mc interference, the condition may be remedied by adding approximately 3 inches to both the white agc and the red B+ leads in the tuner. These lengthened leads should be dressed away from other possible interference sources. *L2* and *L8* should then be returned.

Beginning with serial No. 185,489, the above change is already made in later production.

PACIFIC MERCURY Chassis
150-41, 150-42

Improved stability and vertical linearity.

With the noise balance control out of the above chassis, it has been found that stability and vertical linearity are improved if the resistance between B+ and the agc grid is reduced to approximately one-half of its former value and the resistor between the grid and cathode on the agc tube is removed. Beginning with the unit having serial No. 188,007, on 20-tube chassis only, the resistor *R19*, from B+ to pin 1 of *V11* (type 6AU6), is 180k ohms, 1/2 watt, part No. PMA-45015-52, and *R16*, the 39k-ohm resistor from pin 1 to pin 7 of *V11* is omitted.

PACIFIC MERCURY Chassis
200, 201-series

Increasing i-f gain.

A 1,500- $\mu\mu\text{f}$, 500-volt ceramic capacitor is used from the plate of the video detector (pin 1, *V4*) to ground. The turns ratio of the i-f output transformer is changed (new part No. PMB-52052-2) and a 10k-ohm, 10%, 1/2-watt resistor is connected across its output leads.

The new transformer and capacitor increase i-f amplification considerably. The 10k-ohm resistor restores the original bandwidth which is slightly reduced in obtaining the added gain.

The above changes are already made in later production, beginning with serial No. 160,725.

PACIFIC MERCURY Chassis
201-series

Reducing picture height in high line voltage areas.

In areas of high line voltage, it may be found that the picture height is so great that it cannot be reduced adequately by means of the height control. To remedy, add a 1.8-meg, 1/2-watt, 10% resistor (part No. PMA-45015-64) from the open end of the height control potentiometer *R47* to ground. The added 1.8-meg resistor reduces height sufficiently to make the front panel control effective in all areas. The above change is already included in later production with serial No. 155,489.

PACIFIC MERCURY Combinations
with 155,160
radio tuners

Minimizing audio hum.

On all combination models using the above a-m radio tuners, a .01- μ f, oil-filled, molded paper bypass capacitor is used on the switch side of the 117-v a-c line to minimize hum in the audio circuit, particularly in the phono position. This capacitor (part No. PMA-41002-45) is designated schematically as C70. It is connected from the switch side of the line to ground. This capacitor is already included in later production beginning with the unit having the serial No. 131,500.

PACIFIC MERCURY Combinations
with 155,160
radio tuners

**Disabling sweep circuits and
eliminating crosstalk on radio
(see Fig. 27).**

The following changes are made in the B+ circuit in all combination models using the above a-m radio tuners. These changes will kill the vertical and horizontal sweep circuits and eliminate crosstalk when on radio. The changes will also prevent depolarizing voltage being applied to the two 20- μ f electrolytic capacitors C43 and C61 during radio operation or in the event of a fuse failure.

1. The 290-v, B+ bus and the negative side of C43 (20 μ f) are disconnected from the junction of R66 and R74.

2. Pin 3 of the adapter socket is disconnected from the 290-v B+ bus.

3. C66 (.25 μ f) is disconnected from pin 3 of the adapter socket.

4. The negative side of C61 and the plate voltage supply for the type 6W4 damper tube, V16, are disconnected from the fused side of the B+ bus.

5. Pin 3 of the adapter socket is connected to the fused side of the 290-v B+ bus.

6. The negative side of C43 and C61, and the plate supply for the damper tube are connected to pin 2 of the adapter socket.

7. The junction of R66 and R74 is also connected to pin 2 of the adapter socket.

8. C66 is connected to the 290-v B+ bus.

Beginning with the unit having the serial No. 128,000, the above changes were instituted in production on all applicable models.

PACIFIC MERCURY Chassis
with
cascode tuner

**Increasing life of cascode
amplifier.**

A 2.7k-ohm, 2-watt resistor is used in series with the 290-volt B+ lead (blue) to the cascode stage of the r-f tuner. The resistor is located at the tie point where the lead to the tuner is connected to the plus 290-v bus. The use of this resistor increases the life expectancy of the type 6BZ7 (or alternate) r-f cascode amplifier by reducing the B+ voltage applied to it.

The resistor (part No. PMA-45019-30) is already added in later

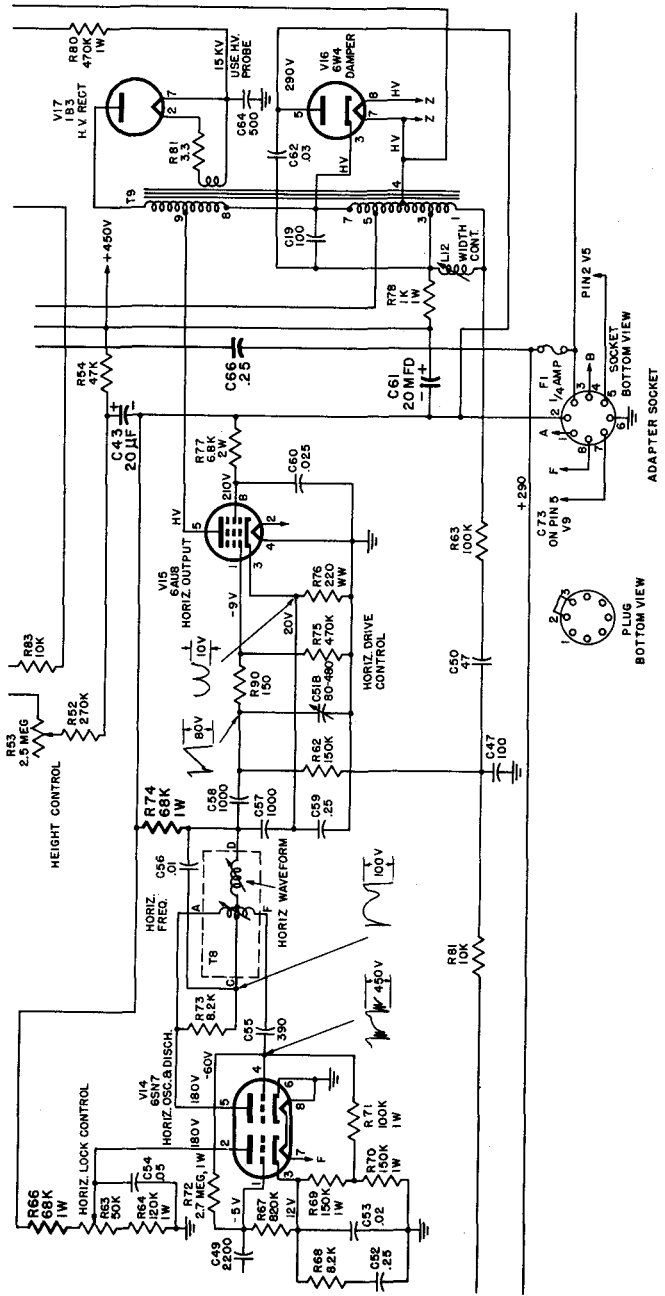

Fig. 27 — Pacific Mercury

production with the unit having the serial No. 158, 573.

PACIFIC MERCURY

Chassis with electrostatic focus picture tube

Improved focus.

Picture tube manufacturers have developed newer and better gun structures for electrostatic focus picture tubes. The focusing element in the crt's with these guns may provide best focus either at ground potential or at +450 volts. If focus difficulties arise in a receiver using an electrostatic focus crt, the focusing element connection should be considered. The connection opposite to the one existing in the set at the time may improve the focus.

Whether the focusing element is grounded or at a potential of +450 volts, the 47k-ohm resistor in series with focus electrode lead must be retained to eliminate audible arcs resulting from internal crt neck arcing. The resistor is connected directly to pin 6, the blue lead of the crt (no tie point is used), and the connection is covered with phenolic sleeve insulation to prevent arcing. The other end of the resistor is grounded or connected to the bootstrap bus (+450 v), whichever provides better focus.



PACKARD-BELL

Chassis T-1,
T-10

Dark vertical bars in picture.

Some early production chassis had interaction between the vertical retrace blanking circuit and the hori-

zontal blanking circuit, causing dark vertical bars on the left side of the picture. This condition is corrected in later production by adding a 220,000-ohm, 1/2-watt resistor between the grid of the picture tube and the high side of the secondary of the vertical output transformer.

PACKARD-BELL

Chassis T-1,
T-10

Vertical instability and horizontal pull.

Vertical instability and/or horizontal pull may appear under strong signal conditions when the set is operating near maximum contrast. Variations in the 6BY6 or 6CS6 sync amplifier tube may cause this condition. Check to make sure that the picture lock control is in the counterclockwise position.

Early production of chassis T-10 did not incorporate the delay agc control switch. The 3rd picture i-f in these chassis had a 120-ohm, 1/2-watt resistor in the cathode (the T-1 chassis has a 220-ohm resistor here) and a 3,300-ohm, 2-watt dropping resistor in the plate and screen circuit. This should be modified to a 270-ohm, 1/2-watt resistor in the cathode, and the plate (pin 5) should be tied directly to B+ through the primary of the third i-f coil. The screen should have a 15,000-ohm, 1/2-watt dropping resistor connected to the B+ line.

PACKARD-BELL

Chassis T-10

Alignment of last i-f transformer.

Alignment of S6 (last i-f transformer) is very critical and should be done with utmost accuracy. Meter alignment of this 43.25-mc circuit is a must. Misalignment of this adjust-

ment will cause a decrease in sync amplitude, leading to vertical instability. The adjustment must not be changed when reshaping the response curve in final alignment.

Note: In some service notes, the S6 frequency is shown incorrectly as 42.75 mc. This should read 43.25 mc.

PACKARD-BELL Chassis T-20
Poor focus.

Some of the above sets reached the field with one end of the focus control not soldered to ground. This is not a critical error due to the electrostatic focusing of the picture tube. However, because of variations in tubes, this condition should be checked in case of poor focus. The ion trap adjustment should also be checked.

PACKARD-BELL Chassis 1840
Increased width at low line voltage.

To provide sufficient width at low line voltage, capacitor C47 (56- μmf , 3,500-volt capacitor connected between lug 4 of the yoke socket and ground) is changed in later production to a 120- μmf , 2,000-volt unit if a Thermadore power transformer is used. If a Triad transformer is used, the value remains at 56 μmf , 3,500 volts.

PACKARD-BELL Chassis 2040
Oscillation in sound i-f driver stage.

To minimize the possibility of oscillation in the sound i-f driver

stage, a 1,000-ohm, $\frac{1}{2}$ -watt isolating resistor is added between the screen of the 6AU6 sound driver (V1, pin 6) and the i-f B+ supply.

PACKARD-BELL Chassis 2040
Improved horizontal linearity.

The screen bypass capacitor (C35) on pin 4 of the 6BQ6 horizontal output tube (V12) is changed from .05 μf to .1 μf to improve the linearity on the right side of the picture.

PACKARD-BELL Chassis 2040
Elimination of fuse failure.

Fuse failure may be caused by flash-over or arcing in the 6AX4 damper tube. No damage to the 6AX4 occurs during this flash-over but the fast-blow $\frac{1}{4}$ -ampere fuse will fail. To remedy this condition, later production incorporates a 3/16-ampere slow-blow fuse. This fuse will not fail unless subjected to a prolonged arc or short. Do not use any fuse larger than a 3/16-ampere slow blow or damage to other components will result should a short occur.

PACKARD-BELL Chassis 2040
Preventing resistor overheating.

The following changes, already made in later production, provide for an increased safety factor in the operation of the components concerned:

1. R32, 1,200-ohm, 10-watt decoupling resistor between +270 volts and the high side of the brightness control, is changed to a 1,200-ohm, 12-

watt unit to prevent overheating of the resistor.

2. *R12*, 560-ohm, 1-watt cathode resistor of audio output tube, is changed to a 560-ohm, 2-watt resistor to prevent overheating.

PACKARD-BELL Chassis 2040
Increasing width.

The following changes, already made in later production, provide for increased drive on the horizontal output stage and increased picture width especially at low line voltages:

1. Capacitor *C33*, 1,500- μmf coupling capacitor to the grid of horizontal output tube, is changed to a .01- μf unit.

2. Resistor *R54*, 18k-ohm peaking resistor in grid circuit of horizontal output tube, is changed to a 15k-ohm unit.

3. Capacitor *C52*, 56 μmf , 3,500-volts, is added in parallel with *C47*, 56- μmf , 3,500-volt capacitor connected between terminal 4 and ground of yoke socket.

PACKARD-BELL Chassis 2040
Preventing vertical oscillator tube socket break down.

To prevent breakdown of the socket of *V14*, 12BH7 vertical oscillator and output stage, the two triode sections are transposed so that terminals 1, 2 and 3 are those of the output section rather than terminals 6, 7 and 8. This change is already made in later production.

PACKARD-BELL Chassis 2040
Stabilizing vertical oscillator.

To stabilize the vertical oscillator, capacitor *C38* (.001 μf) is re-

moved from the circuit. This capacitor is connected to the secondary of vertical oscillator transformer *T3*. This change is already made in later production.

PACKARD-BELL Chassis 2040
Preventing overload of video amplifier.

To prevent overloading video amplifier 12AU7, resistor *R77* (330 ohms) is inserted between the low end of the contrast control and ground. This addition is already made in later production.

PACKARD-BELL Chassis 2040
Increasing agc voltage.

To increase agc voltage, resistor *R9* (2.2 meg) is removed from the circuit in later production. This resistor was connected to pin 6 of *V3* (6AV6, 1st audio and agc clamp.).

PACKARD-BELL Chassis 2040
Preventing h-v breakdown in high altitudes.

To prevent high voltage breakdown in areas of high altitude, resistor *R79* (10,000 ohms at 2 watts) is connected between the screen grid (pin 4) of the horizontal output tube and *R56* (also 10,000 ohms at 2 watts). This addition is already made in later production.

PACKARD-BELL Models 2115,
2116, 2117, 2118
Excessive damper tube failure.

A 6U4GT was used in the damper circuit in a few early production sets. This tube is replaced with a 6AX4GT, with which it is interchangeable.

PACKARD-BELL Models 2115,
2116, 2117

**Decreasing power drain
on 6CD6.**

To decrease power drain on the 6CD6 tube, the following resistor changes, already made in later production, are affected:

1. R53, 18k-ohm resistor in grid circuit, is changed to 10k ohms.

2. R54, 220k-ohm resistor in grid circuit, is changed to 330k ohms, 10%.

PACKARD-BELL Models 2115,
2116, 2117

Removing "shadow" on picture.

To remove "shadow" on the picture, a change in picture phasing is made. This is accomplished by changing C50, .005- μ f capacitor connected between pin 10 of the picture tube and the vertical discharge tube output circuit, to a .01- μ f, 600-volt capacitor. This change is already made in later production.

PACKARD-BELL Models 2115,
2116, 2117

**Reducing pulse on power
transformer.**

To lower pulse on power transformer, the 10k-ohm, 5-watt, wire-wound resistor and 56- μ f, 2-kv ceramic capacitor (in series) from pin 8 of 6U4GT to C43 (yoke balancing capacitor) was deleted. This has already been done in later production.

PACKARD-BELL Model 2118

Improving gain.

To improve gain, a 6CB6 tube is used in place of the 6AU6 in the 1st video i-f stage. This change is already made in later production.

PACKARD-BELL Model 2118
**Decreasing picture compression
on right and increasing width.**

To decrease picture compression on the extreme right side of the raster and to increase width, two changes, already made in later production, are included:

1. C34, cathode resistor of horizontal output tube, is changed from a .5- μ f, 600-volt tubular capacitor to a 5- μ f, 50-volt electrolytic.

2. C49, .1- μ f, 600-volt tubular capacitor connected between pins 1 and 2 of the 6AL5 afc tube and pin 8 of the yoke socket, is changed to a .05- μ f, 600-volt tubular capacitor.

PACKARD-BELL Models 2421,
2422, 2423

**Reducing overshoot or halo
effect on some stations.**

Although the frequency response of these models is not as wide as the 26-tube series, some overshoot or halo effect is noticed on some stations. This can be reduced by clipping C24 (330 μ f) from the cathode of the 2nd video amplifier to ground. Due to the physical layout of the 24-tube chassis it has been possible to bring a lead from C24 to the top of the chassis near the low voltage power transformer where it is grounded. Clipping this wire will remove the capacitor from the circuit without the necessity of removing the chassis from the cabinet.

PACKARD-BELL Models 2421,
2422, 2423

**Preventing picture tube
"lockout".**

During early production, some difficulties were experienced with a

form of "lockout" which was caused by the wide variation in grid cut-off voltage encountered with electrostatic tubes. On some tubes where the grid cut-off was in the vicinity of 35 to 45 volts, advancing the contrast control beyond normal would make the grid of the picture tube draw current. This in turn, reduced the high voltage, thereby reducing the keying pulse below normal for the keyed agc. When this happened, the i-f strip was

running wide open which aggravated the situation even more. To compensate for this condition, a 100k-ohm resistor is inserted between the arm of the brightness control and the picture tube cathode.

This form of cathode limiting, controls the amount of current that can be drawn by the anode of the picture tube without affecting the high voltage regulation.

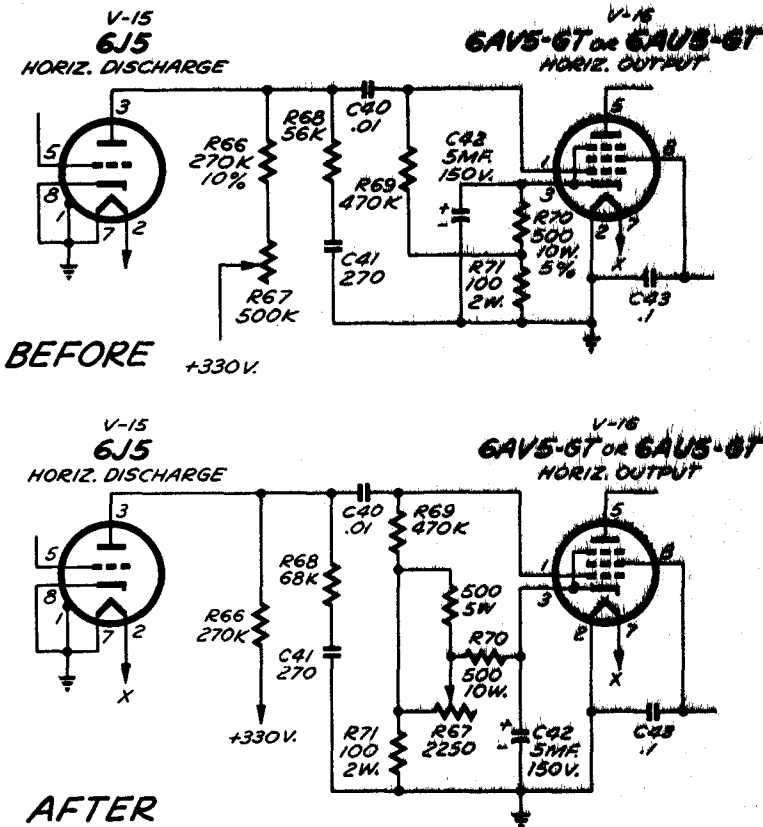

Fig. 28 — Pacific Mercury

PACKARD-BELL Models 2421,
2422, 2423

Vertical oscillator buzz.

Due to the spacing between the 6J5 vertical oscillator and the 6V6 audio output, a 60-cycle buzz may occur. This may be cured by replacing a glass 6J5 with a metal tube. This condition is most noticeable when set is not on station.

PACKARD-BELL Models 2421,
2422, 2423

Width reduction and improved keying pulse (see Fig. 28).

In some areas, where high line voltages are encountered, excessive width has been reported which could not be compensated for by setting the horizontal drive control. Later production incorporated the change as shown in the figure to give a further reduction in width.

In conjunction with this modification, a change is made in connections to the high voltage transformer. The junction point of C44 (.05 μ f) and R73 (5,600 ohms) is moved from tap 3 to 1. This changes the turns ratio with reference to the keying pulse tap thereby increasing the keyed pulse for the keyed agc about 75 percent. This makes the keyed agc much more stable under varying line voltage conditions.

PACKARD-BELL Models 2721,
2722, 2723, 2724,
2921, 2922

Preventing regeneration in fringe areas (see Fig. 29).

Unless the following precautions are taken in fringe areas, some re-

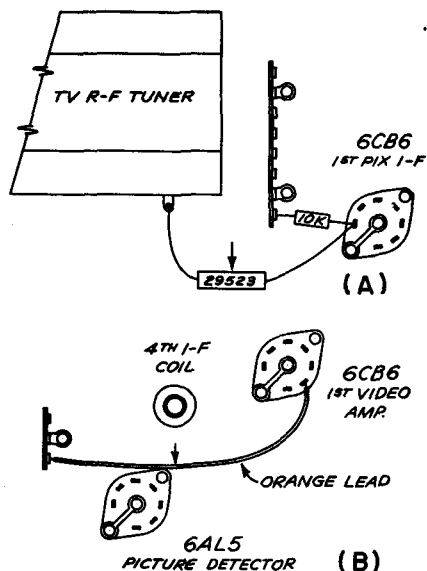

Fig. 29 — Packard-Bell

generation may occur which will contribute to noise in the picture.

1. It has been found that in some cases where signal strength is low, the positioning of the tuner coupling coil (part No. 29523) on models 2723, 2724 and 2921 only, is very important. This coil is located near the r-f tuner, and is wound on a 1-watt resistor. Positioning should be as far from the r-f tuner as the length of the leads allow. See part (A) of the figure.

2. The orange lead from pin 6 of the 6CB6 1st video amplifier to the terminal strip should be routed as far as possible from the 4th i-f coil (part No. 29554). See part (B) of the figure.

PACKARD-BELL Models 2721,
2722, 2723, 2724
**Improving overall audio
response.**

Engineering modifications were incorporated in later production of the above models to improve the overall audio response. It is recommended that the following changes be made where poor signal-to-noise ratio is encountered.

1. Add resistor, composition 1.5 megohm, $\frac{1}{2}$ watt, 20%, part No. 73163. This resistor is connected between the plates of the 6AV6, (V4) and the 6V6GT, (V5).

2. Replace capacitor C13, .005 μ f, with a .01- μ f capacitor. This is the bypass on the 6V6 audio output tube. Use a .01- μ f, 600-volt tubular capacitor (part No. 23006).

PACKARD-BELL Chassis 2740,
2840, 2940, 3040
**Improvement of sound in
fringe areas (see Fig. 30).**

Poor sound reception may occur in fringe localities, particularly in areas receiving uhf signals. This problem occurs due to adjacent channel rejection of the 39.75-mc traps.

As the fine tuning control is varied from left to right, the sound carrier moves into the trap area, resulting in decreasing sound. With the following change, the sound level will stay approximately the same throughout the fine tuning range.

Later production of the above chassis will not contain the 39.75-mc trap (L9) nor the 4.7- μ f capacitor coupling it to the grid of the 3rd picture i-f tube (V8). Also, the grid resistor (R29) on this tube, 3,300 ohms, $\frac{1}{2}$ watt, is replaced by an 8,200-ohm, $\frac{1}{2}$ -watt resistor. The alignment frequency of L10A (3rd i-f coil) is changed from 42.5 mc to 42.1 mc. On the response curve, the bandwidth marker 42.25 mc at 50% of the curve maximum is changed to 42.1 mc at 60% of the curve (see diagram). Terminal 3 of V6 (1st picture i-f) has an additional ground lead soldered to the chassis right at the terminal.

If the above sound problem exists, the changes mentioned are recommended in the field. Complete realignment of the set will be necessary.

All sets already incorporating these changes will have the number "507" stamped on the chassis rear apron, and also on the carton.

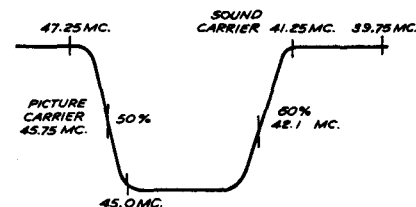

Fig. 30 — Packard-Bell

PACKARD-BELL Chassis 2740,
2840, 3040
Insufficient sound gain.

Later production chassis incorporate part No. 29054 ratio detector transformer. Early production had part No. 29068 ratio detector transformers and in some cases insufficient gain was found. When replacing

part No. 29068 with part No. 29054, resistor $R7$ (82 ohms) should be changed to a 470-ohm, $\frac{1}{2}$ -watt resistor. Also add 22k-ohm, $\frac{1}{2}$ -watt resistor connected from screen of 6CB6 driver ($V2$, pin 6) to 135-volt bus.

In addition, resistor $R1$, 10,000 ohms, $\frac{1}{2}$ watt, is removed from the receiver. This is connected across the sound i-f input coil $L1$.

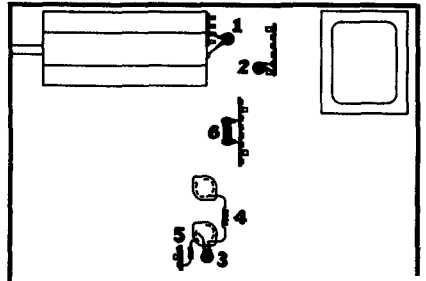

Fig. 31 — Packard-Bell

PACKARD-BELL Chassis 2740,
2840, 3040 with
vhf/uhf tuner 10535C

Preventing regeneration
(see Fig. 31).

To prevent regeneration on the above chassis used with tuner 10535C, the following changes, made in later production, are included:

1. Capacitor, ceramic, 5,000 $\mu\mu\text{f}$, (part No. 23931) is added as bypass from r-f tuner filament terminal (C) to ground.
2. Capacitor, ceramic, 10,000 $\mu\mu\text{f}$, (part No. 23939) is added as bypass from 135-volt bus at power transformer to ground. The ground lug of the terminal strip must be soldered to chassis.
3. Capacitor, ceramic, 5,000 $\mu\mu\text{f}$ (part No. 23931) is added as bypass from pin 4 to pin 7 of $V9$, 4th picture i-f.
4. Radio frequency choke (part No. 29551) is added between pin 4 of $V8$ and pin 4 of $V9$. These points were formerly connected directly together.
5. Resistor, 100 ohm, $\frac{1}{2}$ watt, (part No. 73013) is inserted between

pin 6 of $V9$ and tie point previously connected to it.

6. $R21$, B+ dropping resistor to r-f tuner (4,700 ohm, 2 watt) is replaced by a 5,000-ohm, 5-watt, 10% resistor (part No. 73640).

PACKARD-BELL Chassis 2740
Sync instability.

Some of the first chassis had the grid resistor $R73$ of the automatic noise inverter tube going to ground. This caused incorrect biasing of the automatic noise inverter tube and its effectiveness was decreased. Instability of vertical and/or horizontal sync may be found in some cases.

Chassis should be corrected by returning $R73$ (47k ohms) grid resistor to the age line (pin 2 of $V10$). Production chassis in which this correction has already been made have the letter "A" stamped on the rear chassis apron near the power transformer.

PACKARD-BELL Chassis 2740
Addition of delayed agec
(see Fig. 32).

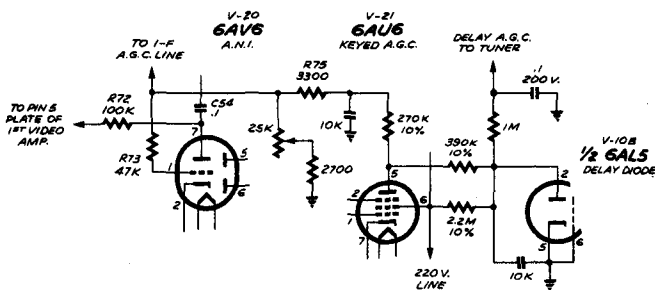

Fig. 32 — Packard-Bell

The addition of delayed agc circuitry is incorporated in later production of the above chassis. Improved performance will be noted in fringe areas, as evidenced by an increase in signal-to-noise ratio due to the r-f amplifier bias being held near zero for low signal input. High signal areas will benefit because of the much greater input signal now required to produce overload or cross modulation effects. Chassis incorporating this delay circuit can be identified by the agc control located on the chassis rear apron near the horizontal drive control.

If the delayed agc circuit is added to a chassis containing a vhf-uhf (all-channel) tuner, the following additional changes must be made:

1. Add ground wire directly to chassis from pin 3 (ground side of heater) on 2nd and 4th i-f tubes, V7 and V9.
2. Add ceramic capacitor, 5,000 $\mu\mu\text{f}$, part No. 23931, between pins 3 and 4 of 2nd i-f tube, V7.
3. Also add a 5,000- $\mu\mu\text{f}$ capacitor, part No. 23931, between pin 6 of picture detector, V10, and tuner side

of 1-megohm isolation resistor in delayed agc circuit.

Complete realignment is necessary upon installation of delayed agc. The 5- μf , 50-volt electrolytic capacitor used during alignment is connected to the tuner agc lead rather than to point 5. Also about 5 volts of agc voltage is used at the tuner during alignment. Finally, a vtvm is connected between point A and ground, and the agc control is adjusted for 3 volts on the meter. This setting will be the most satisfactory for average reception conditions. In some cases of extreme fringe or high signal, it may be possible to improve performance by readjustment of the agc control to produce a minimum of noise or interference in the picture.

PACKARD-BELL Chassis 2740
Increasing tone control range.

In early production of above chassis, capacitor C11 was .005 μf . Its value is changed to .01 μf to increase the range of the tone control. This is the series capacitor in the tone control section.

PACKARD-BELLChassis
with uhf**Improved uhf fringe area
reception.**

It should be noted that in uhf areas where reception is critical, antenna crossover networks should not be used. There is enough loss in many of these networks to cause an appreciable increase in snow. In fringe areas, separate antennas are recommended for vhf and uhf.

**PHILCO**Deflection chassis
D-181, D-191,
D-194, D-204, D-208**Eliminating picture bend.**

To eliminate picture bend, capacitor *C803*, or *C802* in D-181 chassis, (connected to pin 7 of 12AU7 horizontal oscillator) is changed from .001 μ f to .002 μ f. This change is already made in later production.

PHILCODeflection chassis
D-181, D-191, D-194**Increasing rectifier life.**

To increase rectifier life, selenium rectifiers *CR100* and *CR101* are changed from 300- or 350-ma units to 450-ma rectifiers part No. 34-8003-8). This has already been done in later production.

PHILCODeflection chassis
D-181, D-191, D-194**Reducing h-v rectifier tube
filament voltage.**

To reduce 1B3GT tube filament voltage, series filament resistor *R103*

(*R102* in D-191 and D-194 chassis) is changed from 4.7 ohms to 5.6 ohms. This change is already made in later production.

PHILCODeflection chassis
D-181, D-191, D-194**Centering range of vertical
hold control.**

To center the range of the vertical hold control in D-181 chassis, resistor *R706* (connected to high side of vertical hold control) is changed from 510k ohms to 390k ohms. This change is already made in production run 10.

In D-191 and D-194 chassis, the above resistor is *R703*. Its value is changed from 220k ohms at 10 percent to 240k ohms at 5 percent. This change is already made in production run 4.

PHILCODeflection chassis
D-181**Improving range of
brightness control.**

To improve brightness control range, *R818* (connected between one side of the width control and lug 9 of interchassis socket *J101*) is changed from 12k ohms to 8,200 ohms (part No. 66-2828340). This change is already made in later production run 7.

(See also "Improving range of brightness and contrast controls" in r-f chassis R-181.)

PHILCODeflection chassis
D-181**Improving vertical retrace
suppression.**

To improve vertical retrace suppression, resistor *R720* (connected to the low side of the vertical yoke) is changed from 22k ohms to 15k ohms (part No. 66-3158340). This change is already made in later production run 5.

(See also "Improving vertical retrace suppression" for r-f chassis R-181.)

PHILCO Deflection chassis
D-181

Improving range of height and width controls.

To increase the range of the height control, resistor *R710* (connected to one side of the height control) is changed from 270k ohms to 390k ohms. This change is already made in later production run 13.

To improve the range of the width control, this control (*R817*) is changed from 10k ohms to 12.5k ohms. In addition, resistor *R816* (connected to the high side of the width control) is changed from 4,200 ohms to 5,000 ohms. This change is already made in later production run 6.

PHILCO Deflection chassis
D-191

Improving range of width control.

To improve the range of the width control, resistor *R818* (connected to low side of width control) is changed from 4,200 ohms to 5,000 ohms (new part No. 33-1360-118). This change is already made in later production run 2.

PHILCO Deflection chassis
D-194

Eliminating hum in radio operation.

To eliminate hum in radio operation, two .047- μ f, 600-volt capacitors are added, one across each selenium rectifier (*CR100* and *CR101*). This change is already made in production run 3.

PHILCO Deflection chassis
D-197

Preventing possible breakdown of B+ boost divider resistor.

To prevent possible breakdown of B+ boost divider resistor, the wattage rating of *R820* is increased from 1 watt to 2 watts. This change is already made in production run 3.

PHILCO Deflection chassis
D-201, D-204,
J-2, J-5

Increasing life of vertical output tube (see Fig. 33).

The life span of the 12B4 tube employed in the vertical output stage can be materially increased by decoupling the stage from B+ and thus lowering the power dissipated in the tube. The D-201 chassis, run 13 or later, will not require this change.

The added circuit changes are illustrated both schematically and by part layout.

1. Mount two 2-lug wiring panels in the locations shown on the accompanying layout drawing. These panels will be referred to as *B10* and *B11*.

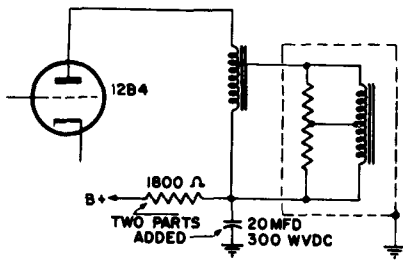
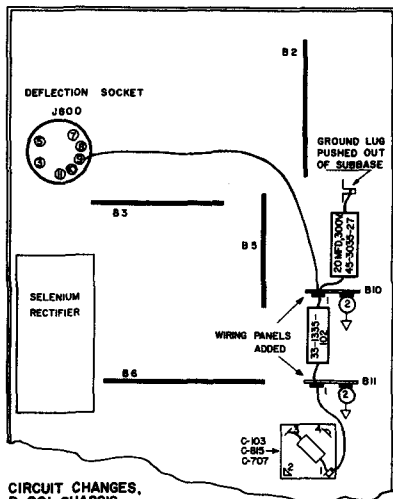

DIAGRAM OF 12B4 VERTICAL OUTPUT CIRCUIT SHOWING ADDED COMPONENTS

(A)



CIRCUIT CHANGES, D-201 CHASSIS, FOR INCREASED LIFE OF 12B4 TUBE

(B)

Fig. 33 — Philco

2. Wire an 1,800-ohm, 5- to 10-watt resistor (part No. 33-1335-102) between lug 1 on wiring panel *B10* and lug 1 on wiring panel *B11*.

3. Wire a 20- μ f, 300-v electrolytic capacitor (part No. 45-3035-27) from lug 1 on wiring panel *B10* to the

lanced lug (ground) pushed out from the chassis subbase.

4. Connect a wire between lug 1 on wiring panel *B11* and lug 1 ($B+$ lug) of the filter capacitor *C103*.

5. Disconnect the red lead of the vertical output transformer and reconnect it to lug 1 on wiring panel *B10*.

6. Disconnect the $B+$ end of the wire between pin 9 of the deflection socket *J800* and $B+$ and connect this end to lug 1 of wiring panel *B10*. Any other wires which may be connected to pin 9 of the deflection socket should be moved to lug 1 on panel *B11*.

In some cases, it may be desirable to provide more vertical sweep. This may be accomplished by lowering the value of the decoupling resistor to 1,500 ohms, 10 watts.

PHILCO Deflection chassis D-204

Preventing overload of 12B4 cathode resistor.

To prevent burning of 12B4 tube cathode resistor due to tube failure, the wattage rating of resistor *R709* is increased from 1 watt to 2 watts. This change is already made in later production run 2.

PHILCO Deflection chassis D-208

Eliminating Barkhausen oscillations (see Fig. 34).

The following changes should be made to eliminate Barkhausen oscillations in the above chassis:

1. Add a .002- μ f, 400-volt capacitor (part No. 30-1238-8 or 30-4650-

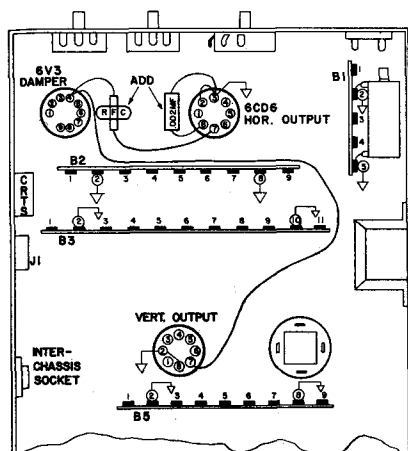

Fig. 34 — Philco

37) between pin 3 and pin 8 of the 6CD6G horizontal output tube. Schematically this capacitor is added from screen grid to cathode of the 6CD6G tube.

2. Remove filament lead between pin 4 of the 6V3 damper tube and pin 7 of the 6CD6G horizontal output tube. Disconnect the remaining filament lead from pin 7 of the 6CD6G tube and connect to pin 4 of the 6V3 damper tube. Add a choke (part No. 32-4112-51) between pin 4 of the 6V3 damper tube and pin 7 of the 6CD6G tube. The figure is a base layout showing the addition of the above parts.

In some few cases, weak Barkhausen lines might still be noticed. Replace the 6CD6G tube in order to remove these lines.

Insufficient width.

For any receivers which indicate insufficient width in models using the above chassis, the following procedure should be used in determining the cause and elimination of this problem. It is assumed that several new 6CD6G tubes have been tried, and that no improvement was produced.

1. Observe the input to the horizontal output tube, 6CD6G, by connecting an oscilloscope through a low capacitance probe to pin 5 of the 6CD6 socket. The waveshape should appear approximately as shown in the service notes.

2. If either the shape or magnitude of the observed wave differs significantly from that shown above, trouble exists in the horizontal oscillator circuit. The following steps should be included in troubleshooting:

- (a) Replace the 12AU7 oscillator tube.
- (b) Check voltages at the oscillator tube socket.
- (c) Examine the oscillator, charging and coupling circuits to insure that components of the correct value are in use.

3. If the input to the 6CD6 tube appears to be correct, the following steps should be taken:

- (a) Check voltages at the socket of the 6CD6 tube.
- (b) If the capacitor wired between lugs 3 and 5 of the flyback transformer is 68

μmf , replace it with an 82- μmf , 5-kv capacitor (part No. 30-1246-6). This change should increase the width. If an 82- μmf capacitor already exists on the transformer, it can be changed to a 100- μmf , 5-kv capacitor. Use part No. 30-1246-2. A check should be made to insure that this change does not introduce ringing or foldover. Excessive leakage of the 68- or 82- μmf capacitor on the flyback transformer or of the 82- μmf capacitor wired to lug 3 and 5 of the yoke socket, will cause a reduction in width. This can quickly be checked by substituting another capacitor.

- (c) If width is still insufficient, the flyback transformer may be defective.

If the above procedure is followed, no difficulty should be experienced in obtaining sufficient width.

PHILCO Deflection chassis
D-208

Improving vertical retrace suppression.

To improve vertical retrace suppression, capacitor C705 (.01- μf unit connected to high side of vertical output transformer secondary) is changed to a .033- μf capacitor. This change is already made in later production run 4.

PHILCO Deflection chassis
D-208

Reducing buzz.

To reduce buzz, the following changes, already made in later production, are included:

1. A 680-ohm damping resistor is added across the secondary of vertical output transformer T701.

2. Resistor R705 (680-ohm peaking resistor in the output circuit of vertical oscillator) is removed. The low end of C701 (.1 μf) is grounded directly.

PHILCO Deflection chassis
D-208

Preventing possible breakdown of B+ boost capacitor.

To prevent possible breakdown of B+ boost capacitor, one lead of C812 (.033- μf unit, connected between lug 5 of horizontal output transformer and ground) is removed from ground and rewired to B+. This change is already included in later production run 6.

PHILCO Deflection chassis
H-1, H-4

Providing brightness compensation.

The following changes, already included in production run 10, are made to provide brightness compensation:

1. A resistor, 8,200 ohms, $\frac{1}{2}$ w, 10%, is added between unused lug of width control (R815) and lug 4 of terminal board B1. This is a 5-lug terminal board mounted parallel and adjacent to the rear apron. Capacitor C815 is already tied to lug 4.

2. A wire was added between lug 4 of terminal board B1 and lug 9 of interchassis socket (J101).

3. A test point is added at the junction of R806 (15k ohms), C806

(2,200 $\mu\mu\text{f}$), and *L800* (30-80 mh), all in the pin 6 plate circuit of 12AU7 horizontal oscillator. Also, the lead from this point to lug 9 of interchassis socket *J101* is removed.

(Note: For accompanying r-f chassis modifications see "Providing brightness compensation" for r-f chassis 81, 84.)

PHILCO Deflection chassis
H-1

Replacing components in pre-assembled horizontal oscillator circuit.

A small number of early-run chassis contained a pre-assembled circuit in the horizontal oscillator stage. Failure of a component in this assembly requires replacement of the assembly. The parts affected are *R800*, *R804*, *C802* and *C803*.

These parts are standard replacement parts obtainable locally and are not listed in the parts list of the service notes. For the technician's information, the parts values and part No. are listed below:

Symbol No.	Value	Part No.
<i>R800</i>	4.7 meg	66-5478240
<i>R804</i>	4.7 meg	66-5478240
<i>C802</i>	.001 μf	30-4650-52
<i>C803</i>	.01 μf	30-4650-52

PHILCO Deflection chassis
H-4

Reducing intermodulation hum.

The following modifications, already made in later production run 8, are included to reduce intermodulation hum:

1. Capacitors *C104* and *C105*, a-c line bypass, are removed.

2. A .047- μf , 600-v capacitor is added from one side of the a-c line (junction of *R100* and *F100*) to chassis.

PHILCO Deflection chassis
J-2, J-5
Eliminating Venetian-blind effect (see Fig. 35).

On some of the early chassis, a condition that is sometimes referred to as a Venetian-blind effect may appear. This condition usually shows up as a pairing of a group of horizontal lines. At normal viewing distance, these groups of paired lines create a variation in shading in the cathode ray tube picture area, thus the Venetian-blind effect. To eliminate this effect proceed as follows:

1. Remove chassis ground from pin 3 of 12AU7 vertical oscillator tube socket and add a 1,000-ohm, 1/2-watt resistor (part No. 66-2108346) between pin 3 and chassis ground.

2. Change resistor *R700*, which is wired in series with the vertical hold control, to 220 ohms, 1/2 watt, 10%, part No. 66-4228346.

Note: These changes are already made in later production run 4 for

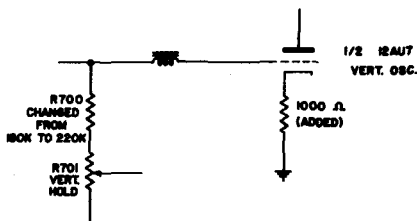

Fig. 35 — Philco

chassis J-2 and in later production run 3 for Chassis J-5.

PHILCO Deflection chassis
J-4

Increasing picture width
(see Fig. 36).

To increase picture width, the following changes, already included in later production run 2, are made:

1. Resistor *R818*, 22k-ohm, 2-watt

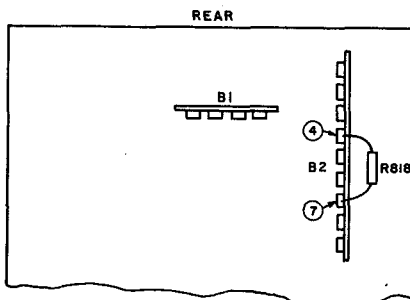

Fig. 36 — Philco

resistor connected between lugs 4 and 7 on terminal board *B2*, is changed to a 33k-ohm resistor.

2. Resistor *R813*, 470k-ohm resistor connected between terminals 5 and 6 of the horizontal output tube socket, is changed to 270k ohms.

PHILCO Deflection chassis
J-4

Reducing hum in radio operation.

To reduce hum in radio operation, a .047- μ f, 600-volt capacitor is connected across the a-c input line across the primary of the filament

transformer. This change is already made in later production run 2.

PHILCO R-f chassis R-181
Improving range of brightness and contrast controls.

To improve brightness control range, resistor *R311* (connected between the arm of brightness control and ground) is changed from 22k ohms to 27k ohms (New part No. 66-3278340).

To improve contrast control range, resistor *R302* (connected across contrast control) is changed from 390 ohms to 470 ohms (New part No. 66-1478340).

Note: These changes have been made in later production. (See also "Improving range of brightness control" for deflection chassis D-181.)

PHILCO R-f chassis R-181
Improving vertical retrace suppression.

To improve vertical retrace suppression, resistor *R310* (connected in series with .1- μ f coupling capacitor to pin 2 grid of picture tube) is changed from 10k ohms to 15k ohms (part No. 66-3158349). This change is already included in production run 17.

(See also "Improving vertical retrace suppression" for deflection chassis D-181.)

PHILCO R-f chassis R-181
Reducing channel 5 picture beat (see Fig. 37).

To reduce channel 5 picture beat, an additional 4- μ h series peak-

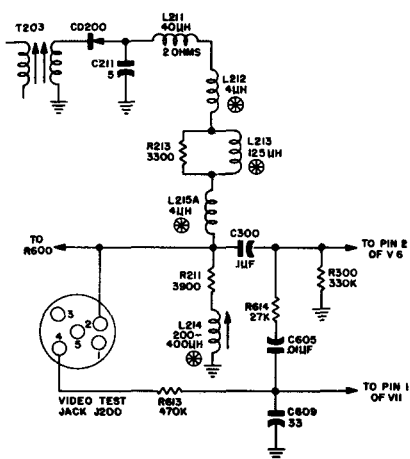

Fig. 37 — Philco

ing coil (*L215A*, part No. 324112-50) is added to the video detector load circuit. To install this coil, terminal board *B9* adjacent to the video test jack is changed from a 2-lug to a 3-lug type. The revised wiring of the video detector circuit, already done in later production run 18, is shown in the figure.

PHILCO R-f chassis R-191,
R-192

Reducing criticalness of i-f circuit.

To reduce criticalness of the i-f circuit, the following changes (already made in later production run 10) are included:

1. Resistor *R213* (12k ohms), capacitor *C216* (1,500 μmf) and *C217* (.1 μf) are all removed. These components are connected between the low side of i-f transformer *T202* (between 2nd and

3rd video i-f stages) secondary and ground. The low side of *T202* secondary winding is grounded at pin 7 of *V5* (3rd i-f stage) tube socket.

2. Capacitor *C603* (connected between pin 1 of *J200* video test jack and ground) is changed from .047 μf to .15 μf .

3. Third video i-f transformer *T203* (output of 3rd i-f stage) is changed to part No. 32-4548-27, and the lower end of the secondary winding is grounded to lug 4 of terminal board *B9* (5-lug terminal board adjacent to 3rd video i-f tube) instead of former grounding point.

4. Resistor *R303*, 6,800 or 4,700-ohm unit across series peaking coil *L301* (250 μh) connected to one side of 4.5-mc trap in plate circuit of 1st video amplifier, is changed to 10k ohms.

5. Capacitor *C213*, connected between screen grid (pin 6) and ground of 3rd video i-f stage, is changed from 560 μmf to 680 μmf .

PHILCO R-f chassis R-191,
R-194

Improved sound gain, reduced sync buzz, and improved sync performance.

The following modifications, already included in later production, are made to improve sound gain, reduce sync buzz, and improve sync performance:

1. Resistor *R601* (connected to pin 7 of 6CS6 sync separator) is changed from 27k ohms to 15k ohms (new part No. 66-3158340).

2. Resistor *R304* is removed. This is a 47k-ohm resistor connected be-

tween screen (pin 6) of *V6*, 1st video amplifier.

3. Capacitor *C406* (connected from *L402* tertiary winding of ratio detector transformer to ground) is changed from 150 $\mu\mu\text{f}$ to 330 $\mu\mu\text{f}$ (new part No. 62-133001001).

4. Capacitor *C401* (across tuned sound takeoff coil *L400* in grid circuit of 1st sound i-f stage) is changed from 18 $\mu\mu\text{f}$ to 10 $\mu\mu\text{f}$ (new part No. 62-010409001).

5. Capacitor *C402* (connected from cathode, pin 7, to ground of the 1st sound i-f stage) is changed from .01 μf to .0022 μf (new part No. 30-465-54).

6. Wiring on lugs of sound takeoff coil, *L400*, is reversed.

PHILCO R-f chassis R-191,
R-207

Preventing overload of contrast control.

To prevent overload of the contrast control, an 1,800-ohm, 10%, 1-watt resistor is added in series with video output tube (*V8*) screen supply. This change is already made in later production.

PHILCO R-f chassis R-191
Eliminating video oscillation.

To eliminate the possibility of video oscillation, particularly at minimum contrast, the following changes, already included in later production, are made:

1. A 3,300-ohm, 10%, $\frac{1}{2}$ -watt resistor is added across video series peaking coil *L304* (connected to intensity grid, pin 2, of picture tube).

2. A 10k-ohm resistor is added across sound boost trap coil *L213A* (if used).

PHILCO R-f chassis R-191
Improving video transient response (see Fig. 38).

To improve video transient response, all wiring is interchanged between lug 8 of terminal board *B4* and lug 2 of terminal board *B5*. A bottom view of the chassis showing these

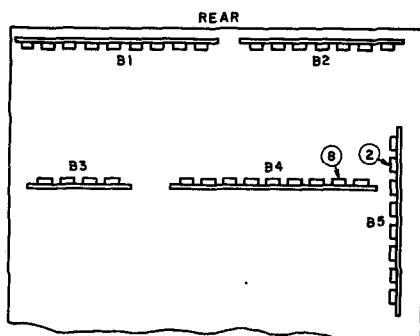

Fig. 38 — Philco

boards is shown in the figure. This change is already made in later production run 3.

PHILCO R-f chassis R-191
Improving sound gain (see Fig. 39).

The following modifications already made in later production run 5, are incorporated in order to improve sound gain:

1. *L213* and *R210* are replaced by a 4.5-mc sound boost trap coil in the

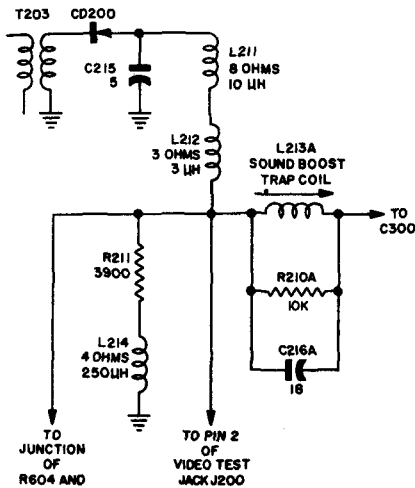

Fig. 39 — Philco

video detector circuit (new part No. 32-4463-7).

2. An 18- μ f capacitor is added across the 4.5-mc sound boost trap coil (new part No. 62-018400021).

3. 4.5-mc trap coil, *L300* is changed to new part No. 32-4463-7. This trap is in plate circuit of 1st video amplifier.

4. Capacitor *C302* (across *L300*) is changed from 68 μ f to 27 μ f. (new part No. 62-027409011).

5. Peaking coil *L301* (connected to one side of *L300*) is changed from 250 μ h to 400 μ h (new part No. 32-4480-5).

6. Resistor *R303* (across *L301*) is changed from 6,800 ohms to 4,700 ohms (new part No. 66-2478340).

Revised wiring of the video detector circuit using sound boost trap coil is shown in the figure.

PHILCO Sync buzz.

R-f chassis R-194

In run 3 of the above chassis, a sync buzz may be encountered in the audio stages. This buzz is found only at times in the run 3 chassis and is due to proximity of a lead near the video amplifier stages running to the grid circuit of the 1st audio amplifier. The particular lead runs from the junction of *R410* and *R415* to *R409*, and should be dressed as far away from the video circuits as is possible.

PHILCO Preventing video oscillation.

R-f chassis R-194

To prevent video oscillation, the B+ lead to the screen grid of 2nd video i-f tube (*V4*) is dressed outside of the i-f shield and away from the crystal detector. This is already done in later production run 3.

PHILCO Improving fringe area performance.

R-f chassis R-204

To improve fringe area performance, capacitor *C226* (cathode bypass connected to pin 2 of the 1st video i-f stage) is changed from 18 μ f to 33 μ f. This change is already included in production run 2.

PHILCO Reducing hum (see Fig. 40).

Models TV-80,

TV-90 series

Hum in the above models is due primarily to the following three causes:

1. Misadjustment of the hum bucking control on e-m speakers.

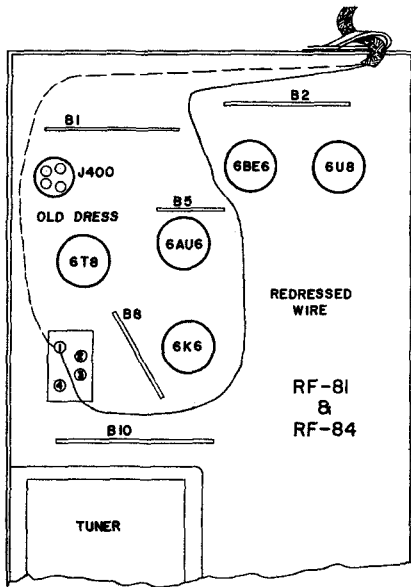

Fig. 40 — Philco

2. Hum bucking voltage too low on some e-m speakers.

3. Hum pickup by components and wiring in the 1st audio stage.

The above causes along with their remedies are discussed below:

1. It must be determined that the hum bucking coil is properly adjusted before proceeding to steps (2) and (3) above.

2. If it is not possible to minimize the hum with the control, it is due to insufficient hum bucking voltage on the hum bucking winding. The position of the control under these conditions is always in the maximum counterclockwise position.

To correct this condition, it is necessary to add about five turns of No. 22 enameled wire to the hum bucking

winding. This winding can be identified near one end of the field coil. The additional turns are added around the field coil at the end where the hum bucking winding is located.

Disconnect one end of the hum bucking winding, and to it connect the end of the added turns so that both windings are in the same direction. Connect the other end of the added turns to the point from which the original end of the hum bucking winding was removed. With the set operating, a position of minimum hum should be found on the hum bucking control. In some few cases, it may be necessary to add more than five turns; however, it is desirable to add the fewest number of turns since too many turns make the adjustment of the control more critical.

3. The most serious cause of hum is due to the pickup by components or wiring of the 1st audio stage. The hum is picked up from the B+ lead which passes by the 6T8 tube. This lead is a white lead connected to pin 11 of the interchassis cable. This lead should be redressed as indicated in the figure.

Note: There has been a practice in the field to bypass the speaker field with a 500- μ f electrolytic capacitor. Under no circumstances, should this fix be used even though it may correct the hum condition, as this causes weave to increase from three to four times under nonsynchronous operation.

PHILCO

Models TV-80
series

Improved sound in fringe areas.

Improvement in sound performance in fringe areas of the above models can generally be obtained by turning in (clockwise) the i-f padder located on the tuner, 1 to 2 turns. This padder is designated as TC-512 in the service notes. An adjustment made in the above manner will bring up the sound side of the i.f.

In areas where strong signals are received as well as fringe signals, the adjustment should not exceed 2 turns since the possibility of deteriorating picture quality might exist.

In extreme fringe areas, further improvement can be made in some cases by adjustment of the secondary of the ratio detector transformer Z400. To make this adjustment, select a weak signal and adjust the top padder (TC402) on the transformer until the maximum noise-free signal is obtained. Care should be taken not to introduce audio distortion.

PHILCO R-f chassis 81, 84 **Improved picture quality.**

The following changes, already made in later production run 11, of r-f chassis 81 are included to improve picture quality:

1. Coil L300, 4.5-mc trap in video plate circuit, is changed to one of less inductance (new part No. 32-4463-2).

2. Capacitor C301, across 4.5-mc trap, is changed from 27 $\mu\mu\text{f}$ to 68 $\mu\mu\text{f}$ (new part No. 62-068409001).

3. Coil L301, series peaking coil in video plate circuit is changed from 250 μh to 180 μh (new part No. 32-4480-9).

4. Coil L302, video output peaking, is changed from a fixed 60- μh

coil to a 60-200 μh variable (new part No. 32-4467-18).

5. Resistor R303, across L301, is changed from 6.800 to 2.200 ohms (new part No. 66-2228340).

6. Coil L214, variable video detector peaking, is changed from 175-500 μh to 200-400 μh (new part No. 32-4467-17).

7. Resistor R213, shunting video detector peaking coil L213, is changed from 6.800 to 3,300 ohms (new part No. 66-2338340).

8. Resistors R216 and R217 in series with high side of link from r-f section, are removed and a single resistor of 220 ohms is added across secondary of T200 (L201), input coupling transformer of 1st video i-f stage (new part No. 66-1228340).

9. Resistors R603, connected to pin 6 plate of sync amplifier, is changed from 22 k, 2 w. to 18 k, 2 w (new part No. 66-3185346).

10. Resistors R609 (1-meg resistor connected to pin 7 sync separator) is changed to a 5% tolerance rating (new part No. 66-5108240).

11. Resistor R619 (connected to agc clamp diode, pin 6 of 1st audio stage) is changed from 15 meg to 10 meg, 5% (new part No. 66-6108240).

12. A 4-lug terminal strip is added to facilitate wiring changes (B-7A).

In the case of r-f chassis 84, all of the above are included in later production run 6. In addition, the following changes are made:

1. The 1,500- $\mu\mu\text{f}$ capacitor C308, connected from cathode (pin 1) of 12BY7 video output tube to ground, is removed.

2. Resistor *R611*, connected to pin 2 of *J200* (video test and fringe switch socket), is changed from 180k ohms to 470k ohms.

PHILCO R-f chassis 81, 84
Providing brightness compensation.

The following modifications, already made in later production run 15, is included to provide brightness compensation:

1. "Hot" end of brightness control *R307* is disconnected from B+ and a lead is added in the chassis interconnecting cable from pin 9 of *PL101* to the "hot" end of the brightness control.

2. Brightness control *R307* is changed from 5 meg to 100k ohms.

3. A 22k-ohm resistor is added from the center lug of the brightness control to chassis.

4. Resistor *R306*, connected to the center lug of brightness control, is changed from 100k ohms to 150k ohms.

(Note: For accompanying deflection chassis modifications see "Providing brightness compensation" for deflection chassis H-1, H-4.)

PHILCO R-f chassis 81, 84
Reducing channel 5 beat.

The following changes, already made in later production run 14 and 15, are included to reduce channel 5 beat:

1. Coil *L212*, 4- μ h video detector peaking coil, is changed from part No. 32-4480-8 to part No. 32-4112-24.

2. I-f shield part No. 56-9714FA8 is changed to a partitioned shield (part No. 56-9714-1FA3, 28-9382FA3).

PHILCO R-f chassis 84
Improving audio characteristics.

The following change, already made in later production run 6, is included to improve audio characteristics. Capacitor *C413*, d-c blocking capacitor between 1st audio stage and the audio output stage, is changed from .01 μ f to .0047 μ f.

PHILCO R-f chassis 84
Improving sync performance.

The following change, already made in later production run 6, improve sync performance:

1. A 33- μ f capacitor is added from grid (pin 1) of 6BE6 sync separator to ground (new part No. 30-033009001).

2. A .01- μ f capacitor is added, in series, between grid (pin 2) of 6U8 sync amplifier and *R600*, 4,700-ohm resistor (new part No. 30-1238-2).

3. A 1.5-megohm resistor is added from grid (pin 2) of 6U8 sync amplifier to ground (new part No. 66-5158346).

4. Resistor *R610*, in grid circuit of sync separator, is changed from 330k ohms to 470k ohms (new part No. 66-4478346).

5. Resistor *R611* connected to pin 2 of *J200* (video test and fringe switch socket), is changed from 180k ohms to 330k ohms (new part No. 66-4338346).

6. Resistor *R613* connected to pin 4 of *J200*, is changed from 1.2 meg to 470k ohms (new part No. 66-4478346).

7. Resistor *R614* connected to grid (pin 1) of 6BE6 sync separator, is changed from 56k ohms to 27k ohms (new part No. 66-3278346).

8. Resistor *R601*, connected to cathode (pin 7) of 6U8 sync amplifier, is changed from 2,700 to 3,300 ohms (new part No. 66-2338346).

PHILCO R-f chassis 84
Eliminating parasitics in audio output stage.

To eliminate parasitic oscillations in the audio output stage, a 220-ohm resistor (part No. 66-1228540) is added from pin 4 of 6L6GA tube (*V9*) to the junction of the screen decoupling components (*C415* and *R207B*). This has already been done in later production run 7.

PHILCO R-f chassis 94
Facilitating video i-f coil alignment.

To facilitate alignment of the 4th video i-f transformer, a 12k-ohm resistor is added across the secondary winding. This change is already made in later production.

PHILCO R-f chassis 94
Reducing audio distortion

To reduce audio distortion, 22-meg resistor is added in parallel with *C417* (.01- μ f capacitor to ground in feedback circuit to grid of 1st audio tube). This change is already made in later production run 3.

PHILCO R-f chassis 94
Permitting use of uhf tuner (see Fig. 41).

To permit use of the uhf tuner with the above chassis, the following changes, already included in later production are made:

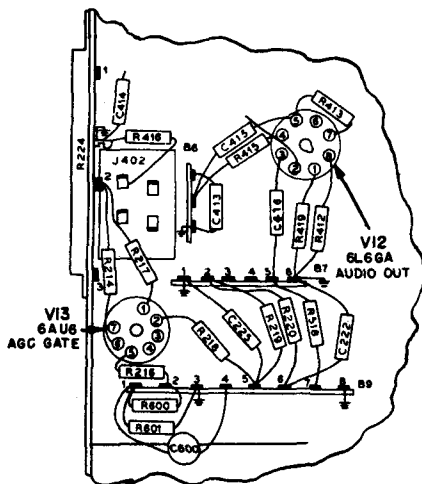

Fig. 41 — Philco

1. Lead of resistor *R518*, 15k ohms, is moved from lug 5 to lug 4 of terminal board *B7*.

2. Red lead of audio output transformer is disconnected from lug 4 of terminal board *B7* and reconnected to lug 4 of audio output tube (*V12*) socket.

3. Lead of capacitor *C416*, 3,300 μ f is removed from lug 5 of terminal board *B7* and reconnected to lug 3 of *R224*.

4. Red lead between lug 4 of terminal board *B7* and lug 5 of audio output tube (*V12*) socket is removed.

5. Female uhf adapter cable (part No. 41-4099-1) is connected to lug 5 of terminal board *B7*.

6. Male uhf adapter cable (part No. 41-4166) connected to lug 4 of terminal board *B7*.



PHILHARMONIC Models 800,
900 series

Overheating of width coil.

On all models having the high voltage transformer in a cage on top of the chassis and using the 6BQ6 horizontal output tube, the width coil may tend to overheat. This is due to having the width coil slug all the way out. If varying the width coil so that the slug is further in the slot does not help, remove 80 turns from the width coil. This will allow the slug to be more in the center of the coil at the same width setting. The part number for the new coil is 10-575.

PHILHARMONIC Models 800,
900 series

Overheating of R51.

In cases where resistor R51 (connected between horizontal output transformer and pins 5 and 7 of 6AL5 phase detector) overheats, the resistor should be replaced with one having the same resistance value (15k ohms) but with a 1-watt power rating.

PHILHARMONIC Models 800,
900 series
with cascode tuner

Black bars on left side of screen.

On models using the cascode tuner only, black bars on the left side of the screen have appeared in a few cases. This is caused by radia-

tion of the high voltage circuit which is picked up by the 1st i-f stage. By putting a small metal shield parallel to the 1B3 tube on the i-f strip, just below the first 6CB6 tube socket, the radiation effect will be decreased, thus eliminating the black bars.



RADIO CRAFTSMEN Models
RC-100, RC-100A,
RC-101, RC-200,
RC-201, RC-202

**Using electrostatic focus
picture tube.**

Electrostatic focus picture tubes require 500 volts dc at pin 6. The lead supplying this voltage is connected to pin 8 of the octal plug at the chassis end of the cable connecting the crt socket to the chassis. Some chassis have this lead, which is blue in color, and the required voltage is available. Other chassis have the extra lead in the connecting cable but have only 320 volts dc connected to pin 3 under the chassis. The wiring must be changed to provide the required 500 volts.

To make the adaptation:

1. Add a lead to the cable between pin 8 of the plug and pin 6 of the crt socket, if needed.
2. Check the presence of 500 volts dc at pin 8 of the octal socket at the rear of the chassis.
3. If a lower voltage is found, remove the wires tied to terminal 8. It is used as a tie point in those chassis not wired for use with electrostatic tubes. Carefully resolder

the leads together and tape them or remove the ground from pin 4 and use it as a tie point. Then add a lead to provide 500 volts, as suggested below.

In models 100 and 100A, 500 volts is available from terminal 1 of the high voltage transformer, the point that connects to the 6W4GT damper tube through the linearity coil.

In earlier models RC-101 and RC-200, the 500 volts is available from terminal 3, the terminal connected to the 6W4GT plate through the .022- μ f capacitor C23.

In later models RC-101 and RC-200, plus all RC-201 models, terminal 4 of the high voltage transformer will deliver the required voltage.

In all cases, the high voltage take-off point should be made from a convenient tie point underneath the chassis, rather than from the suggested terminal of the transformer itself. When a variable voltage is desired to control the focus, add a 5-megohm potentiometer from the 500-volt take-off point to ground and connect the arm of the "pot" to pin 8 of the octal socket.

When changing to an electrostatic focus tube, remove the magnetic focalizer from the back of the deflection yoke. Use a 16X408 centering magnet in its place. The ion trap remains the same and is used in the same position.

Automatic or fixed focus electrostatic tubes are available which contain an internal connection to the focus anode. No external lead is necessary. However no control over the focus is possible. Examples of such tubes are the 17KP4 and 17RP4.

RADIO CRAFTSMEN

Models

RC-100, RC-100A,
RC-101, RC-200,
RC-201, RC-202

Adding uhf reception.

The above models contain turret-type tuners which can be adapted for uhf reception. Just insert uhf strips into an unused channel of the turret tuner. These strips contain special frequency multiplier circuits which will produce the desired 26-megacycle i-f frequency.

Coils should be ordered by channel number. The letter "Q" should be added for C-202 cascode tuners or other models that have been modernized by the installation of a cascode tuner. The letter "F" should be used for all other models. For ex-

Models RC-200 which contain the continuous-type tuner will not be adaptable for uhf reception. Those owning this type of chassis have two alternatives for receiving uhf programs:

1. The turret-type tuner can be installed instead of the continuous-type tuner and the above information will apply to it as well. It should be borne in mind that the f-m reception is lost by this adaptation.

2. The continuous-type tuner may be kept (retaining f-m reception) and a uhf converter can be purchased separately.

RADIO CRAFTSMEN

Models

RC-100, RC-100A

Horizontal drift.

Horizontal drift is usually caused by unstable capacitors in the

horizontal oscillator and control circuits. *C76*, 100- μ f electrolytic in cathode circuit of horizontal control tube; *C67*, 1,000- μ f capacitor between terminal *A* of horizontal oscillator transformer and pin 7 (cathode) of horizontal control tube; and *C68*, .015- μ f capacitor across *C67*, are all especially critical.

To eliminate horizontal drift, replace the following capacitors:

1. Replace *C67* with a 470- μ f ceramic capacitor with a negative 5250 parts per million shift (part No. 18X619).

2. Replace *C68* with a mica or good grade plastic capacitor. *C68* will have a value of .015 μ f (part No. 18X301) for earlier models and .01 μ f (part No. 18X304) for later models.

3. Replace *C76* with a 100- μ f, 15-volt electrolytic with an impedance of .5 ohm at 15,750 cycles. A Mallory type WP510 (or part No. 18X021) should be used. If not available, a 300- μ f tubular capacitor at 15 volts can sometimes be substituted.

After replacing these capacitors, it is necessary to stabilize them by use. After the receiver has been used two or three times, they will become fully effective.

RADIO CRAFTSMEN

Models

RC-101,

RC-200, RC-201

Installation of cascode tuner

(see Fig. 42).

The use of the cascode tuner results in approximately twice the sensitivity or half the snow of the former turret-type tuner. This increased

sensitivity is important in fringe areas but does not result in a noticeably better picture in strong signal areas.

How to Install the Cascode Tuner:

Remove the old tuner and the Booster Switch lever arm assembly. Leave the Booster Switch wired into the circuit but push the switch lever toward the rear of the chassis.

The cascode tuner is directly interchangeable with the original tuner in the above-mentioned models. Wire the new tuner into the circuit according to part (A) of the figure before mounting the sound takeoff coil assembly.

Add a 15k-ohm, 1/2-watt resistor from the r-f test point to ground as shown in part (B) of the figure.

How to Install the Sound Take-off

Coil:

Mount the sound take-off coil (part No. 5S019A) directly behind the cascode tuner. Use the elongated hole (see part C of the figure) as a guide in locating two 5/32-inch mounting holes. Drill the holes. Enlarge the elongated hole with a 5/16-inch drill to provide a hole for tuning the coil later. Mount the coil in the position indicated in part (D) of the figure.

How to Add a Delayed-AGC

system:

A delayed and graded automatic gain control must be added in order to obtain optimum performance. The new circuit correctly proportions the gains of the r-f and i-f amplifier stages for minimum snow in fringe areas and prevents overload effects in strong signal areas. The new cir-

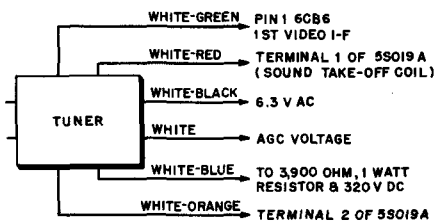

(A)

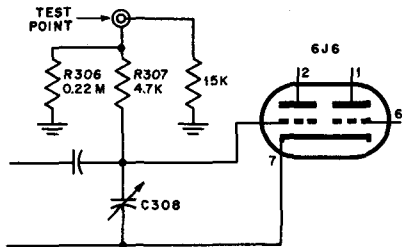

(B)

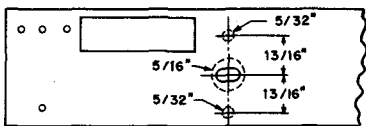

(C)

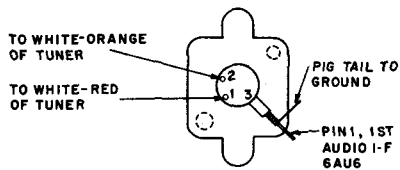

(D)

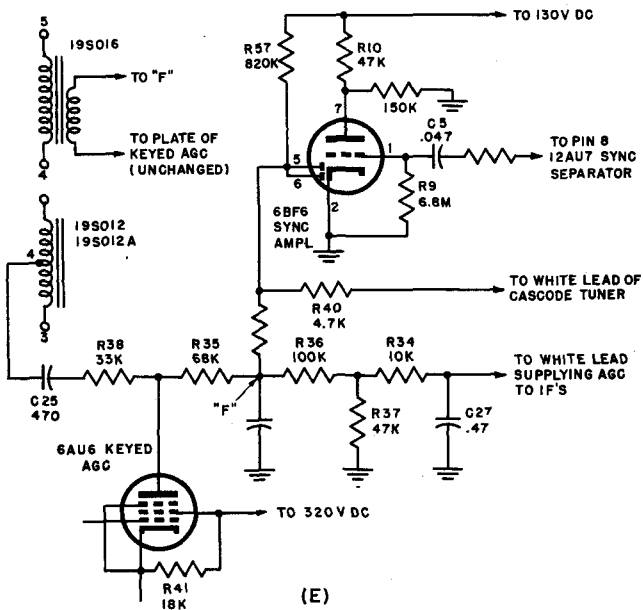

(E)

Fig. 42 — Radio Craftsmen

circuit combined with a new sync amplifier circuit, is shown in part (E) of the figure. It is suitable for use with either the 16kv flyback transformer (19S016) or the 13.5-kv transformers (19S012 and 19S012A).

A comparison of the new circuit and the old will show that most of the resistors and capacitors in the old circuit remain unchanged. However, the 6.8k-ohm screen dropping resistor, *R44* should be removed. Also, *R41* (screen to cathode bleeder) should be changed from 33k to 18k ohm, 1 watt.

How to Change the Sync Amplifier Circuit:

The 6C4 sync amplifier must be changed to a 6BF6 to secure diodes for the agc delay circuit. See part (E) of the figure. Note that the value of *R10* has been changed to 47k ohms and that a 150k-ohm resistor has been added from pin 7 to ground. Also an 820k ohm resistor has been added from pin 7 to ground. Also an 820k ohm resistor has been added between pins 5 and 6 and resistor *R10*.

How to Align the I-F Stages and Sound Take-Off Coil:

Follow the alignment procedure given in the service instruction for the model being converted. The video i-f alignment calls for the insertion of a variable negative d-c voltage between point *F* of the figure and ground. Eight volts is usually about right. The tuning slug for making the alignment of the video i-f output of the tuner to the video i-f stages is located on top of the new tuner, the one with the adjusting screw at an

angle. The correct frequency is 23.5 mc.

How to Align the Oscillator Circuit:

Although the cascode tuner is pre-tuned, the r-f oscillator tuning slugs must be readjusted after installation. They usually shift with handling.

Turn the set on and turn the selector control or knob to the desired channel. Turn the fine tuning control to its mid-point. Remove the selector control knob and the fine tuning knob. Use a non-inductive screwdriver to adjust the tuning slug. The slug is reached through the small hole behind the knobs. The circuit is made so that tuning for the best sound automatically gives the best picture. Detuning the sound slightly may give a brighter picture, but the definition and overall clarity will not be as good as when the slug is tuned for the best sound.

RADIO CRAFTSMEN

Model
C-210

Reducing high voltage for use with 70-degree picture tubes.

The above receiver is designed to operate 90-degree deflection picture tubes of 21-, 24- and 27-inch sizes. If these are not available, the chassis can be adapted to drive a 70-degree magnetic focus picture tube by making the following changes:

1. Substitute a 6BG6 for the 6CD6 horizontal output tube.
2. Solder a jumper across the 12, 000-ohm, 2-watt resistor attached to pin 8 of the horizontal output tube socket.
3. Clip out the 1,000- μ f mica capacitor connected between ground

and the white (agc) lead on the h-v transformer.

4. Adjust the vertical size and linearity controls for a symmetrical picture.

This modification will result in a high voltage of 15 kv instead of the 18kv used with 90-degree tubes.

RADIO CRAFTSMEN Model
C-210P

Insufficient width.

A horizontal width control has been left on the above model purposely, since it is possible to set the B+ accurately by means of taps on the power transformer. If the B+ is correctly set, insufficient width indicates either incorrect assembly of the deflection components or a defect in the circuit, and it would be masking the defect to change sweep and high voltage by means of a width control.

If insufficient sweep is encountered, the fit of the yoke against the neck of the picture tube should first be checked. The yoke should be forward, flush against the body of the tube, and the magnet focus magnet should be flush against the yoke. Also, check the ion trap adjustment and the positioning of the focus magnet.

If assembly of the unit is correct, B+ should be checked, taking the reading from the output of the filter choke. If B+ is lower than 350 volts, check the 5U4G rectifier, and make sure it is of good quality. If a good quality rectifier is used and the B+ still reads low, change the tap on the power transformer to bring the B+

to normal, between 350 and 360 volts. If the B+ reading is normal and there is insufficient width, a defective yoke or high voltage transformer is indicated.

RADIO CRAFTSMEN Models
with 19S012,
19S012A h-v
transformer

Increased high voltage and picture brightness.

To increase high voltage and picture brightness, part No. 19S016 high voltage transformer is substituted for part No. 19S012 or 19S012A.

19S012A is the same as 19S016 so far as connections are concerned. The only difference is that 19C016 delivers 16 kv as compared with 12.5 to 13 kv from the 19S012A.

Changes are necessary in order to use 19S016 instead of 19S012 as follows:

**

19S012 Lead on Pin	19S016 goes to Pin
3	4
4	11
5	7
7	5
8	6
9	1

1. The .056- μ f capacitor should be connected between pins 5 and 6 of the 19S016.

2. Add a .047- μ f capacitor between pin 5 of the 19S016 and pin 2 of the horizontal linearity coil (the pin with a yellow wire going to cathode pin 3 of 6W4).

3. Change *R32* (screen dropping resistor of 6BQ6) from 15k ohm, 10 watts to 18k ohms, 10 watts.

To eliminate foldover from the right side of the picture when a 19S016 is being installed, the following changes should be made:

1. Cut *C9*, (.022- μ f capacitor connected to pin 1 and 2 of sync discriminator) and *R18* (100-ohm resistor connected to same pins) out of the afc circuit. Also cut, *C25*, (470 μ f), *R38* (68k ohms) out of agc circuits from pin 4 of h-v transformer.

2. Add a .01- μ f capacitor and a 33k-ohm, 1/2-watt resistor in parallel from pins 1 and 2 of the 6AL5 horizontal discriminator tube to ground.

3. Add a 22k-ohm, 1-watt resistor and a .047- μ f capacitor in series from pins 1 and 2 of the horizontal discriminator tube to pin 5 of 6AU6 agc tube.

4. Add a wire from pin 8 of the 19S016 to pin 5 of the 6AU6 agc tube.

5. Add a wire from pin 10 of the 19S016 to the junction of *R34* (10k ohms), *R36* (68k ohms) and *C26* (.47 μ f) to supply the agc voltage.

6. Add a 1.0 to 2.2-ohm, 1/2-watt wirewound resistor in the pin 7 filament lead of the 1B3 to prevent the filament voltage from exceeding 2 volts ac.

RADIO CRAFTSMEN Models
with cascode tuners
**Eliminating buzz in strong
signal areas (see Fig. 43).**

Receivers operating in unusually strong signal areas are sometimes

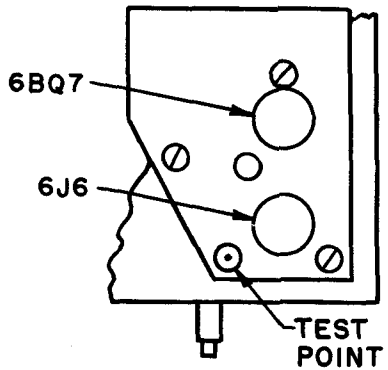

Fig. 43 — Radio Craftsmen

overloaded and a buzz or hum is heard in the speaker. To eliminate the buzz on models equipped with the turret-type tuner, especially the cascode tuner, add a 15,000-ohm, 1/2-watt resistor from the r-f test point to ground.

When making this circuit change, also be sure that the resistor from pin 7 (plate) of the 6BF6, sync amplifier, to ground is 150,000 ohms, 1/2 watt, and that *R10* (also connected to pin 7) has a value of 47,000 ohms, 1/2 watt.



RAYTHEON

Chassis 17T1,
17T2, 21T1, 21T2

Improving sync stabilization.

To improve sync stabilization, the following changes, already made in later production coded 432, are included:

1. *R64*, connected to pin 6 of 6BE6 sync clipper, is changed from

27k ohms at 1 watt to 22k ohms at 5 watts.

2. *R77*, B+ boost dropping resistor to plate circuit of vertical oscillator, is changed from 220k ohms to 100k ohms at $\frac{1}{2}$ watt.

3. *C98*, connected from afc discriminator to pin 4 (grid) of the horizontal multivibrator, is changed from 5,000 μmf to .01 μf at 200 volts.

4. *C113*, 1,000- μmf , 500-volt ceramic capacitor, is added between pin 5 (plate) of 6AX4 damper tube and ground.

5. *L34*, choke coil part No. 201-15608, is added between pin 3 (cathode) of 6AX4 damper tube and lug 4 of h-v transformer.

RAYTHEON Chassis 17T1,
17T2, 21T1, 21T2

Improving vertical sync.

To improve vertical sync, the following change, made in later production coded 932, is included. *R65*, 12k-ohm resistor connected to plate (pin 5) of 6BE6 sync clipper, is changed to 33k-ohm, $\frac{1}{2}$ -watt unit.

RAYTHEON Chassis 17T1,
17T2, 21T1, 21T2

Increasing vertical scan.

To increase vertical scan, *V13*, vertical oscillator output tube, is changed from a 12SN7 to 12BH7. A noval socket is used instead of the original octal socket. Pins 1, 2 and 3 are the plate, grid and cathode respectively of the output section, while pins 6, 7 and 8 are the plate, grid and cathode respectively of the oscillator section. This change is already made in later production coded 542.

RAYTHEON Chassis 17T1,
17T2, 21T1, 21T2

Eliminating channel 6 oscillation.

To eliminate channel 6 oscillation, the following changes are made:

1. *R9*, 2,200-ohm resistor connected to plate (pin 1) of the 12AT7 converter oscillator, is changed to 100 ohms at $\frac{1}{2}$ watt.

2. *L9*, cathode choke connected to pin 3 of 12AT7 converter oscillator, is removed.

3. *R10*, 2,200-ohm, $\frac{1}{2}$ -watt resistor is connected between the cathode (pin 3) of the 12AT7 and ground.

4. Grid resistor *R8* (10k ohms), connected to pin 2 of the 12AT7 converter oscillator, is returned to the cathode (pin 3) instead of to ground.

These changes are already included in later production identified by a yellow splash on the tuner.

RAYTHEON Chassis 17T1,
17T2, 21T1, 21T2

Extending range of vertical hold control.

To extend the range of the vertical hold control, *R83* (330k-ohm resistor connected between the arm of the vertical hold control and ground) is changed in later production to 470k ohms, $\frac{1}{2}$ watt. Note: If a 12BH7 vertical tube is used instead of a 12SN7, *R83* should be increased to 560k ohms.

RAYTHEON Chassis 17T1,
17T2, 21T1, 21T2

Decreasing 1X2A filament voltage.

To decrease the filament voltage of the h-v rectifier, *R100*, a 2.2-ohm filament dropping resistor, is changed in later production to 3.9 ohms, 1/2 watt.

RAYTHEON Chassis 17T1,
17T2, 21T1, 21T2

Replacement for fusible resistor.

If fusible resistor *R82* (part No. 46 M-20681) is not available for replacement, a 7.5-ohm, 5-watt resistor in series with a 1.6-amp 125-volt fuse may be substituted.

RAYTHEON Chassis 17T1,
17T2, 21T1, 21T2

Eliminating left-hand shading.

To eliminate left-hand shading, *C113* (connected from pin 5 of the damper tube to ground) is changed from 1,000 μmf to .01 μf at 500 volts (ceramic). This change is already made in later production coded 213.

RAYTHEON Chassis 21T3

Eliminating sync buzz.

To eliminate sync buzz, the following changes are made:

1. *R56* and *R57*, 470k-ohm resistors connected to screen (pin 6) of 6AU6 agc amplifier, are changed to 47k ohms.

2. *C99*, 5,000- μmf ceramic capacitor, is added between pin 6 of the agc amplifier and ground.

3. In strong signal areas, full agc voltage is connected to the tuner r-f stage.

The above changes are already made in later production.

RAYTHEON Chassis 21T3
Improving sync stability.

To improve sync stability, the following changes, already made in later production coded 742, are included:

1. *R52* and *C79* (47k-ohm resistor and .1- μf capacitor connected to pin 6 of 6BE6 sync separator) are both removed and pin 6 is wired directly to pin 8 (cathode) of the 6V6 vertical output tube.

2. *C78*, 33- μmf capacitor connected to pin 1 of the sync separator, is removed. *R48* (47k ohms) now connects directly to pin 1.

3. *R50*, connected between pin 1 of the sync separator and the arm of the noise rejection control, is changed from 330k ohms to 1 meg.

4. *R53*, connected to plate (pin 5) of the sync separator, is changed from 390k ohms to 22k ohms.

5. *R55*, connected to grid (pin 7) of 12AT7 sync amplifier, is changed from 470k ohms to 22k ohms.

6. *R117*, connected to grid (pin 1) of 6SN7 horizontal multivibrator, is changed from 33k ohms to 68k ohms.

7. *C77*, connected to pin 7 of the sync separator, is changed from 470 μmf to .047 μf .

8. *C80*, connected to plate (pin 5) of sync separator, is changed from .047 μf at 200 volts to .047 μf at 400 volts.

9. *C118*, connected to *R117* (above), is changed from .047 μf to .22 μf .

10. *C119*, connected from grid (pin 1) of the horizontal multivibrator to ground, is changed from .047 μf to .0022 μf .

11. *C98*, 22- μf ceramic capacitor, is added between pin 7 of the sync separator and ground.

RAYTHEON Chassis 21T3
Stiffness in tuning (see Fig. 44).

If stiffness in tuning is noticed, the following is suggested as a means of obtaining a smooth continuous tuning action.

Apply Lubriplate or a similar lubrication to the pulleys, pilot light bar, stop washers, switch lever and arm. Also check that the switch lever

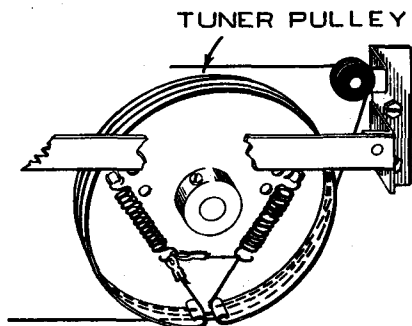

Fig. 44 — Raytheon

arm does not bind to the tuning shaft and that it does not rub against the escutcheon.

Caution: When applying lubrication, care must be used to keep Lubriplate off the dial string as slipping and stretching may result.

If dial string replacement is necessary, it is recommended that lubrication be applied and the improved stringing method may be used as shown in the figure.

To reduce horizontal waves, capacitor *C437* (.22- μf unit connected in the pin 2 grid circuit of the horizontal multivibrator) is changed to .1 μf . This change is already made in later production coded 243.

RAYTHEON Chassis 21T8,
21T11

Increasing resolution.

To increase resolution, *R417*, connected to pin 10 of the picture tube, is wired to boosted B+ instead of 240 volts. This change is already made in later production coded 443.

RAYTHEON Chassis 21T8,
21T11

Improved vertical retrace.

To improve vertical retrace, the following changes, already included in later production coded 543, are made:

1. *R419*, 3,300-ohm resistor connected in the intensity grid circuit of the picture tube, is changed to 5,600 ohms.

2. *R418*, 1,800-ohm resistor connected to intensity grid (pin 2) of the picture tube, is changed to 22k ohms.

3. *C443*, 100- μf ceramic capacitor, is connected between pin 2 of the picture tube and ground.

RAYTHEON Chassis 21T8,
21T11

Reducing horizontal phase shift.

To reduce horizontal phase shift, *R403*, 47k-ohm resistor connected to pin 1 (grid) of 6BE6 sync clipper, is changed to 68k ohms. This is already done in later production coded 233.

RAYTHEON Chassis 21T8,
21T11

Improving sync.

To improve vertical and horizontal sync, R434 (47k-ohm resistor connected to pin 1 plate of 12AU7 sync amplifier) is changed to 100k ohms. This change is already made in later production coded 933.

RAYTHEON Chassis 21T8,
21T11

Eliminating "sand" in picture.

To eliminate "sand" in picture, video trap coil L407 with C445 (part No. 201-22571) are inserted between the cathode (pin 11) of the picture tube and the video output coupling capacitor. This change is already made in later production.

RAYTHEON Chassis 21T8
Maintaining uhf oscillation at

low line voltage.

To maintain the amplitude of uhf oscillations at 105 volts a-c input, R327 (22k-ohm, 2-watt resistor connected to B+ terminal of uhf power socket) is changed to a 12k-ohm, 2-watt resistor. This change is already made in later production coded 733.

RAYTHEON Chassis 21T8
Improving 40-mc rejection.

To improve 40-mc rejection, the following changes, already made in later production coded 643, are included:

1. C100 and C101, 100- μ f capacitors in uhf antenna input circuit, are changed to 5- μ f ceramic units.

2. L107 and L108, uhf antenna trap coils part No. 13E-23181, are connected between uhf tuner antenna input terminals and ground.

RAYTHEON Chassis 21T11,
24T3

Increased sensitivity.

To increase sensitivity, V2 (6BQ7A, vhf r-f amplifier) is changed to a 6BZ7. This is already done in later production.

RAYTHEON Chassis 21T11,
24T3

Improving i-f response.

To improve i-f response, R306 (connected to pin 1 grid of 2nd i-f amplifier 6CB6) is changed from 33k ohms to 22k ohms. This change is already made in later production coded 134.

RAYTHEON Chassis 24T3
Eliminating squeal in

Phono position.

To eliminate horizontal multivibrator squeal interference in the Phono position, add R472 (3.3. meg) between pin 7 of 12AU7 horizontal multivibrator and Phono position contact on Phono-TV switch S400B. This change is already made in later production coded 133.

RAYTHEON Chassis 24T3
Providing more width and
maintaining high voltage.

To provide more width and maintain high voltage, the following changes, already made in later production coded 333, are included:

1. *R505*, 33k-ohm, 2-watt screen dropping resistor for the 25CD6, is changed to 6,800 ohms at 2 watts and is wired to pin 4 (+220 volts, point *A*) of the power plug on the high voltage subchassis.

2. *R507*, 10-ohm, 1-watt filament dropping resistor for 1B3 h-v rectifier, is changed to 6.8 ohms at 1/2 watt.

3. Capacitor *C443*, 47- μmf capacitor connected to pin 2 of 6AL5 afc discriminator, is changed to a 22- μmf ceramic unit.

4. Pin 4 of the deflection subchassis power socket is wired to 240 volts.

RAYTHEON Chassis 24T3 **Increasing brightness and video capability.**

To increase brightness and video capability, the following changes, already included in later production coded 433, are made:

1. *C406*, .033- μf capacitor connected to pin 2 of the picture tube, is changed to .047 μf at 400 volts.

2. Brightness control high side is wired to 300 volts.

RAYTHEON Chassis 24T3 **Accommodating variety of 12AU7's.**

To accommodate varied 12AU7 (*V21*, horizontal multivibrator) tube characteristics, the following changes, already made in later production coded 533, are included:

1. *C507*, 5,000- μmf ceramic disc capacitor, is added between pin 6 of the power plug in the h-v subchassis and ground. (Note: If sync is affect-

ed, insert *L502*, choke coil part No. 16A-23165, between pin 6 and *C507*. Also, change *C507* to .22 μf at 400 volts.)

2. *R467*, 1,500-ohm resistor between pins 3 and 8 of 12AU7 horizontal multivibrator and ground, is changed to 1,800 ohms.

3. *R474*, 220-ohm resistor, is added between i-f detector output jack and the grid (pin 1) of 6AH6V video amplifier.

RAYTHEON Chassis 24T3 **Increasing vertical sync stability.**

To increase vertical sync stability, the following changes, made in later production coded 833, are included:

1. *R403*, 15k-ohm resistor connected to pin 6 of 6BE6 sync clipper (*V8*) is removed.

2. *R406*, 15k-ohm plate bleeder resistor for the sync clipper, is changed to 33k ohms.

3. *C405*, .047- μf capacitor connected to pin 7 of sync clipper, is changed to .01 μf at 400 volts.

4. *R441*, 68k-ohm resistor connected to plate (pin 7) of 6AV6 sync amplifier, is removed.

5. Vertical size control is wired to 480-volt boost source.

6. *R403*, 1-meg resistor is connected between pin 5 of *V8* and 220-volt point *B*.

7. *V16*, 6AV6 sync amplifier, is replaced by a 6BF6.

8. *R439*, 22k-ohm resistor connected to the plate (pin 7) of the 6BF6 sync amplifier, is changed to a 22k-ohm, 2-watt unit.

INDEX

	Page	Page
A		
Afc circuit, horizontal, checking, <i>General Electric</i> , 20C150, 20C151, 24C101	7	
Afc horizontal, improving stability of <i>Muntz</i> , 17B8	59	
Agc circuit checking <i>General Electric</i> , 20C150, 20C151, 24C101	67	
<i>Jackson</i> 317A, 320A, 321A, 324A	20	
Agc control, addition of, <i>Hoffman</i> 190 series 306, 307, 308	13-14, 17-18	
Agc voltage, increasing, <i>Packard-Bell</i> , 2040	71	
Alignment, changing to eliminate smear, <i>Hoffman</i> , 407, 408, 410	18-19	
extreme fringe areas. <i>Mars TV</i> , 630-K35	34-35	
of last i-f transformer, <i>Packard-Bell</i> , T10	69-70	
video i-f coil, facilitating, <i>Philco</i> , 94	91	
Arcing, high voltage, <i>Motorola</i> , TS-410,	51-52	
<i>Magnavox</i> , 250-series	31	
Arc-over, prevention in h-v compartment, <i>General Electric</i> , 21C201, 202, 204, 206, 208 210, 214, 21T1, 3, 6		
Arc-over, prevention in picture tube, <i>Motorola</i> , TS-402, 502, 505, 507, 524 series	49	
Area control, increasing range, <i>General Electric</i> , 17C127, 17T15, 17T17, 21C114, 115, 116, 117, 119, 120, 121, 21T10, 21T12, 21T14	3-4	
Audio characteristics, improving, <i>Philco</i> , 84	90	
Audio distortion, reducing, <i>Philco</i> , 94	91	
Audio sensitivity, improvement of <i>General Electric</i> , 25C101	8-9	
B		
B+boost capacitor, preventing possible breakdown, <i>Philco</i> , D-208	82	
B+boost divider resistor, preventing possible breakdown, <i>Philco</i> , D-197	79	
Barkhausen Oscillation, see Oscillation, Barkhausen,		
Beat on channel 5, reducing, <i>Philco</i> , 81, 84	90	
Bend in picture, elimination of <i>Philco</i> , D-181, D-191, D-194, D-204, D-208	78	
Bending, intermittent <i>Montgomery Ward</i> , 25G- and 35WG- series	38-39	
Black bars on left side of screen <i>Philharmonic</i> , 800, 900 series with cascode tuner	92	
Black line or blotches on right side of raster, <i>Magnavox</i> , all chassis with uhf	32	
Blanking improved, <i>Motorola</i> , TS-292, -410 series	43	
Brightness, increasing <i>Raytheon</i> , 24T3	103	
Brightness compensation, <i>Philco</i> , 81, 84,	90	
improving range of <i>Philco</i> , D-181, R-181	78, 84	
providing <i>Philco</i> , H-1, H-4	82-83	
Brightness control, has little effect, <i>Motorola</i> , TS-602 with 24-, 27- inch picture tube	55	
Buzz, audio, prevention of <i>Meck</i> , 9043, 9044, 9045, 9047, 9048, 9049, 9050, 9051, 9053, 9054, 9055	36	
reducing, <i>Muntz</i> , 17B8	60	
Buzz, intercarrier, reduction of, <i>Hoffman</i> , 301, 302	16	
Buzz, in strong signal areas, elimination of, <i>Radio Craftsman</i> , models with cas- code tuners	98	
Buzz, reduction <i>Magnavox</i> , 108-series	29-30	
<i>Philco</i> , D-208	82	
Buzz, sync, <i>Philco</i> , R-194	87	
eliminating, <i>Raytheon</i> , 2173	100-101	
reduced, <i>Philco</i> , R-191, R194	85-86	
vertical oscillator, <i>Packard-Bell</i> , 2421, 2422, 2423,	74	
C		
Cabinet finish imprints, removal of <i>Hoffman</i> , all chassis	20	

	Page
Cascade amplifier, increasing life of <i>Pacific Mercury</i> , chassis with cascade tuner	67-69
Cascade tuner, adaptation, <i>Hoffman</i> chassis with tuners 9684, 9716, 9717 & 99532	19-20
installation of, <i>Radio Craftsmen</i> , RC-101, RC-200, RC-201	94-96
Centering horizontal, improvement, <i>Motorola</i> , TS-410 series, TS-525 series	51, 53
Channel 7 feedback, prevention, <i>Hoffman</i> , 301, 302	17
Component failure, minimizing, <i>Muntz</i> , 17B8	60
reduction in high line voltage areas <i>Meck</i> 9043, 9044, 9045	36
Component replacement in pre-assembled horizontal oscillator circuit <i>Philco</i> , H-1	83
Compression, elimination at top of picture, <i>General Electric</i> , 17T10, 17T11, 17T12	4
Contrast control, improving range of <i>Philco</i> R-181	84
preventing overload, <i>Philco</i> , R-191, R-207	86
Contrast reserve, increasing <i>Motorola</i> , TS-602 series	55
Contrast-to-brightness ratio improving, <i>Motorola</i> , TS-402, 502, 505, 507, 524-series	50
Corona, <i>Hoffman</i> , 200, 201	15
<i>Magnavox</i> , 250-series	31
Crosstalk on radio, eliminating, <i>Pacific Mercury</i> , combinations with 155, 160 radio tuners	67
Crystal diode, replacement, <i>General Electric</i> , 17C125, 20C107, 21C201, 202, 204, 206, 208, 210, 214, 21T1, 3, 6	1
D	
Damper tube failure, excessive, <i>Packard-Bell</i> , 2115, 2116, 2117, 2118	71
Detector can assembly, replacement of components in, <i>General Electric</i> , 17C125, 20C107, 21C201, 202, 204, 206, 208, 210, 214, 21T1, 3, 6	2
Delayed agc, addition of <i>Packard-Bell</i> , 2740	76-77
Doubler electrolytics, failure of <i>Montgomery Ward</i> . 25BR-3058, 3061, 3067, 3068, 3069, 35BR-3158, 3167, 3168, 3169	38

	Page
Drift, excessive after warm-up <i>Majestic</i> , combinations with a-m/f-m chassis 801, 802	34
horizontal, <i>Radio Craftsmen</i> , RC-100, RC-100A	93-94
vertical <i>Magnavox</i> 300-series	31
Drive bar, elimination, <i>Montgomery Ward</i> , 25WG- 35WG- 3060, 3066, 3070, 3071, 3072, 3073, 3075, 3077, 3079	41
E	
Electrolytic capacitors reducing coupling between, <i>Muntz</i> , 17B8	59
Electrostatic focus picture tube use of <i>Radio Craftsmen</i> , RC-100, RC-100A, RC-101, RC-200, RC-201, RC-202	92-93
F	
Filament transformer, replacement <i>General Electric</i> , 17C125, 20C107, 21C201, 202, 204, 206, 208, 210, 214, 21T1, 3, 6	1
Focus adjustment, <i>General Electric</i> , 21T10, 21T11	8
<i>Magnavox</i> , 250-series	30-31
Focus control, providing added protection for, <i>Motorola</i> TS-292, 410 series	43-44
Focus drift, <i>Motorola</i> , TS-602 with 24-, 27-inch picture tube	55
Focus, improved <i>Hoffman</i> 306, 307, 308, 407, 408, 410,	18, 19
<i>Pacific Mercury</i> , chassis with electrostatic focus picture tube	69
poor, <i>Packard-Bell</i> , T-20	70
Foldover, extreme horizontal, <i>Motorola</i> TS-292	45
horizontal, reducing <i>Motorola</i> , TS-292 series	44
intermittent <i>Montgomery Ward</i> , 25WG-series 35WG-series	38-39
top picture, prevention, <i>Hallcrafters</i> , 1100D, G1100D	10
vertical eliminating, <i>Motorola</i> , TS-602 series	54
Fringe area performance improving, <i>Philco</i> , R-204	87

	Page
Fuse failure, elimination of, <i>Packard-Bell</i> , 2040	70
Fuse replacement <i>Pacific Mercury</i> , 150, 200-series	61
Fusible resistor, replacement for, <i>Raytheon</i> , 17T1, 17T2, 21T1, 21T2	100

G

Gain, i-f, increasing, <i>Pacific Mercury</i> , 200, 201-series	66
improving, <i>Packard-Bell</i> , 2118	72
Globar filament resistor, checking, <i>General Electric</i> , 17C125, 20C107, 21C201, 202, 204, 206, 208, 210, 214, 21T1, 3, 6	1-2
Globar resistor voltage sensitive, checking, <i>General Electric</i> , 20C105, 20C106 20T2, 21C200, 21T4, 21T5	5

H

Halo effect on some stations, reducing, <i>Packard-Bell</i> , 2421, 2422, 2423	72
Height adjustment, <i>Magnavox</i> , all chassis with 74-degree picture tube	32
Height changes, reduction of, at different brightness settings, <i>General Electric</i> , 17T10, 17T11, 17T12,	4
Height control, improving range of <i>Philco</i> D-181	79
Height, insufficient <i>Majestic</i> , 112-, 113-series	32-33
High-voltage breakdown, <i>Hoffman</i> , 200, 201	15
High voltage breakdown in high altitude, prevention of, <i>Packard-Bell</i> , 2040	71
High voltage filter capacitor, addition of, <i>Hallcrafters</i> , 1200D-series	11
High voltage flash-over, within picture tube and vertical output tube, <i>Motorola</i> , TS-292, 410-series	43
High voltage for use with 70-degree pic- ture tubes, reducing, <i>Radio Craftsmen</i> , C-210	96-97
High voltage, increasing, <i>Motorola</i> , TS-502, 505, 507, 524- series	52
<i>Radio Craftsmen</i> , models with with 19S012, 19S012A h-v trans- former	96-97
maintaining <i>Raytheon</i> , 24T3,	102-193

Page

High voltage rectifier tube filament voltage reducing, <i>Philco</i> , D-181, D-191, D194	78
Hold loss of, <i>Motorola</i> , TS-410, series	51
Horizontal deflection system troubles, servicing, <i>Motorola</i> , TS-402, 418, 502, 518, 525, 528, 531, 603, 609	48-49
Horizontal drive, critical <i>Magnavox</i> 105-series	28
Horizontal hold control preventing video from radiating into it, <i>Motorola</i> , TS-402, 502, 505, 507, 524 series	49
Horizontal jitter, see Jitter, horizontal,	
Horizontal oscillator stability, improve- ment <i>Hallcrafters</i> , A1100D, F1100D	9
Horizontal output transformer and yoke, replacement, <i>General Electric</i> , 17C125, 20C107, 21C201, 202, 204, 206, 208, 210, 214, 21T1, 3, 6	2
Horizontal output transformer, improve- ment, <i>Hoffman</i> , 196	15
prevention of excessive loading, <i>Hoffman</i> , 190, 191, 192	12-13
replacement <i>General Electric</i> , 25C101	8
Horizontal output tube, protection of <i>General Electric</i> , 214T, 21T5	8
Hum, audio, elimination of <i>Magnavox</i> 105-series	28-29
minimizing, <i>Pacific Mercury</i> combinations with 155, 160 radio tuners	67
in radio operation, reducing, <i>Philco</i> J-4	84
elimination of, <i>Philco</i> , D-194	79
intermodulation, reducing <i>Philco</i> , H-4	83
loud on uhf, <i>Motorola</i> , split-sound chassis with uhf converter	55-56
reducing, <i>General Electric</i> , 20C105, 20C106, 20T2, 21C200	5-6
<i>Magnavox</i> 108-series, 300-series sep- arate audio amplifier	29-30, 31
<i>Philco</i> , TV-80, TV-90 series	87-88

I

I-f circuit, reducing criticalness of, <i>Philco</i> R-191, R-192	85
I-f input capacitor, installation of when interchanging tuners, <i>Hoffman</i> , 303, 306	17

	Page
I-f tube replacement, <i>Jackson</i> , 317A, 320A, 321A, 324A,	20-21
I-f response, improving <i>Motorola</i> , TS-525 series	53
Interference, adjacent channel, <i>Pacific Mercury</i> , 150-series	63-65
adjacent channel, removal of <i>Magnavox</i> 104-series	22-23
amateur on channel 10, <i>Motorola</i> all chassis	58-59
beat on channel 8, <i>Motorola</i> , TS-502, 524	52-53
4.5-mc reduction of, <i>Pacific Mercury</i> , 150-series	65-66
i-f reduction <i>General Electric</i> 21C225, 226, 227, 228, 229, 230, 231, 232, 233, 21T120, 21T21	7-8
to broadcast receiver <i>Montgomery Ward</i> , 25WG- 35WG- 3060, 3066, 3070, 3071, 3072, 3073, 3075, 3077, 3079, 3160, 3170, 3177, 3180, 3190	40-41
Interlace improvement, <i>General Electric</i> , 17C127, 17T15, 17T17, 21C114, 115, 116, 117, 119, 120, 121, 21T10, 11, 12, 14, 15, 19	2-3
<i>Halicrafters</i> , A1100D, F1100D	9
<i>Motorola</i> TS-292 series	44-45
Instability, sync, <i>Packard-Bell</i> , 2740	76
vertical, <i>Montgomery Ward</i> , 25WG-3071, 3072, 3073, 3075, 3077, 3079	39-40
<i>Packard-Bell</i> T-1, T-10	69
vertical prevention of, <i>Muntz</i> , all chassis	61

J

Jagged picture at high line voltage, <i>Magnavox</i> , 105N-series	29
Jitter, horizontal, <i>Montgomery Ward</i> , 25WG-, 35WG- 3060, 3066, 3070, 3071, 3072, 3073, 3075, 3077, 3079, 3160, 3170, 3177, 3180, 3190	40
<i>Hoffman</i> 200, 201, 202	15
intermittent <i>Montgomery Ward</i> 25WG-, 35WG- series	38-39
Jitter, vertical, minimizing in fringe areas, <i>Hoffman</i> , 301, 302, 303 306, 307, 308	16
prevention of, <i>Meck</i> , 9026, 9032, 9033, 9034	36

K

Keying pulse, improved, <i>Packard-Bell</i> , 2421, 2422, 2423	74
---	----

L

Leakage, heater-to-cathode of V10, re- duction of, <i>Motorola</i> TS-292 series	45
Locking, horizontal, critical, <i>Motorola</i> , TS-402, 418, 502, 518, 525, 528, 531, 603, 604	48
Linearity, horizontal, improved, <i>General Electric</i> , 21C225, 226, 227, 228, 229, 230, 231, 232, 233, 21T20, 21T21	7
<i>Motorola</i> TS-502, 505, 507, 524 series	52
<i>Packard-Bell</i> 2040	70
Linearity, vertical, improving, <i>Motorola</i> , TS-602 series	54
<i>Pacific Mercury</i> , 150-41, 150-42	66
vertical, poor <i>Majestic</i> , 112, 113,-series	32-33

N

Neck shadow, minimizing <i>Muntz</i> , 17B8	60
reduced, <i>Motorola</i> , TS-525 series	53
Noise, background, reducing in picture <i>Magnavox</i> , 105-series	27
Noise inverter, checking, <i>General Electric</i> , 17C125, 20C107, 21C201, 202, 204, 206, 208, 210, 214, 21T1, 3, 6	1
Nonlinearity, vertical at high contrast <i>Motorola</i> , TS-402, 502, 505, 507, 518, 524	50

O

1X2A filament voltage, decreasing, <i>Raytheon</i> , 17T1, 17T2, 21T1, 21T2,	99-100
Oscillation, Barkhausen, <i>Mattison</i> TV-630-6A, 630-6B,	35
<i>Motorola</i> , all chassis	57-58
elimination of, <i>Philco</i> , D-208	80-81
reducing, <i>Motorola</i> , TS-292 series	44
Oscillation, sound i-f driver stage, <i>Packard-Bell</i> , 2040	70
video eliminating <i>Philco</i> , R-191	86
preventing <i>Philco</i> R-194	87
Oscillation on channel 6, <i>Motorola</i> , TS-402, 502, 505	50-51

eliminating, <i>Raytheon</i> , 17T1, 17T2, 21T1, 21T2	99
Oscillator adjustment, <i>Magnavox</i> , all chassis with 700458-1 tuner	32
Oscillator horizontal, intermittently in- operative, <i>Montgomery Ward</i> , 25WG-, 35WG- series	38-39
Oscillator, uhf, checking <i>Montgomery Ward</i> , 35BR-3158A, 3167A, 3168A, 3169A	42
Overdrive, horizontal, reducing, <i>Motorola</i> , TS-410 series	51
Overshoot, reducing, <i>Packard-Bell</i> 2421, 2422, 2423	72

P

Parasitics in audio output stage, elimina- tion of, <i>Philco</i> , 84	91
Peaking adjustments, tuning tool for, <i>Motorola</i> , chassis with TC-101 uhf converter	56
Pentode tuner, replacement with cascode tuner, <i>Hallicrafters</i> , 1200D-series	11
Picture beat on channel 5, reduction of, <i>Philco</i> , R-181	84-85
Picture brightness, improved, <i>Hoffman</i> , 407, 408, 410	19
Picture compression on right, decreasing, <i>Packard-Bell</i> , 2118	72
Picture contrast improved in fringe areas, <i>Hoffman</i> , 306, 307, 308	18
Picture, flashing, <i>Motorola</i> , TS-402, 502, 505	50-51
Picture height, in high line voltage areas, <i>Pacific Mercury</i> , 201-series	66
Picture pulling, preventing during over- modulation, <i>Motorola</i> TS-602 series	54
Picture quality, improvement, <i>General Electric</i> , 17C125, 20C107, 21C201, 202, 204, 206, 208, 210, 214, 21T1, 3, 6	2
<i>Philco</i> , 81, 84	89-90
Picture size, insufficient, <i>Motorola</i> , TS-502	53
Picture shift, at maximum contrast, <i>Hoffman</i> , 210, 211, 212, 213	15
Picture slide reduction, <i>General Electric</i> , 20C105, 20C106, 20T2, 21C200	5-6
Picture, snowy, <i>Motorola</i> , TS-292	45
Picture tube grid current, decreasing at maximum brightness, <i>Motorola</i> , TS-418, 518-series	52

Picture tube lockout, prevention, <i>Packard-Bell</i> , 2421, 2422, 2423	72-73
Picture tubes, using a larger unit, <i>Hallicrafters</i> , 1200D-series	11-12
Picture width, increasing, <i>Philco</i> , J-4	84
"Pie-crusting", at high line voltage, see Jagged picture,	
Phase shift, horizontal, reducing <i>Raytheon</i> , 21T8, 21T11	101
Plastic grill cloth, warping or sagging <i>Motorola</i> , models with plastic grill cloth	55
Pulling, horizontal, <i>Motorola</i> , TS-402, 418, 502, 518, 525, 528, 531, 602, 603, 609	45, 47, 55
<i>Packard-Bell</i> , T1-T-10	69
Pulling horizontal prevention of, <i>Meck</i> , 9026, 9032, 9033, 9034	35-36
reducing in strong signal areas, <i>Motorola</i> , TS-402, 502, 505, 507, 524- series	49
Power transformer, replacement, <i>General Electric</i> , 17C127, 17T15, 17T17, 21C114, 115, 116, 117, 119, 120, 121, 21T10, 11, 12, 14, 15, 19	3
reducing pulse on, <i>Packard-Bell</i> , 2115, 2116, 2117	72

R

R51, overheating of <i>Philharmonic</i> , 800, 900 series	92
Raster small, <i>Motorola</i> , TS-292	45
Receiver protective device, replacement of, <i>Montgomery Ward</i> , 25BR-3058, 3061, 3067, 3068, 3069, 35BR-3158, 3167, 3168, 3169	37-38
Reception uhf fringe areas improved, <i>Packard-Bell</i> , chassis with uhf	78
Rectifier life, increasing, <i>Philco</i> , D-181, D-191, D-194	78
Regeneration, prevention, <i>Packard-Bell</i> , 2740, 2840, 3040, with vhf/uhf tuner 10535C	76
Regeneration in fringe areas, prevention of, <i>Packard-Bell</i> , 2721, 2722, 2723, 2724, 2922	74
Resistor overheating, prevention of, <i>Packard-Bell</i> , 2040	76-77
Resolution, increasing, <i>Raytheon</i> , 21T8, 21T11	101
Response, i-f improving <i>Raytheon</i> , 21T11, 24T3	102
overall audio, improvement of, <i>Packard-Bell</i> , 2721, 2722, 2723, 2724	75

	Pages
video improved, <i>Motorola</i> , TS-292 series	44
video, transient improved, <i>Philco</i> , R-191	86
Retrace blanking, improvement, <i>Hallcrafters</i> , A1100D, F1100D	9
Retrace line, eliminations, <i>Hoffman</i> , 306, 307, 308	17
Ringing, reduction of, <i>Pacific Mercury</i> , 150-, 200- series	62-63
Roll vertical, <i>Magnavox</i> , 300-series	31
S	
S-distortion, <i>Meck</i> 9026, 9032, 9033 9034	35-36
Safety factor, increased, <i>Motorola</i> , TS-602 series	54
Sand in picture, elimination <i>Raytheon</i> , 21T8, 21T11	102
Scan, vertical, increasing, <i>Raytheon</i> , 17T1, 17T2, 21T1, 21T2	99
Sensitivity, improvement, <i>Magnatvox</i> , 104-series	22
increased, <i>Raytheon</i> , 21T11, 24T3	102
increasing on high channels, <i>Motorola</i> , TS-402, 502, 505, 507, 524, series	49-50
Shading, left-hand, eliminating, <i>Raytheon</i> , 17T1, 17T2, 21T1, 21T2	100
on left side of raster, <i>Montgomery Ward</i> , 25BR-3058, 3061, 3067, 3068, 3069; 35BR-3158, 3167, 3168	38
Shadow on picture, removal of, <i>Packard-Bell</i> , 2115, 2116, 2117	72
Shift horizontal, reducing at varying contrast settings, <i>Motorola</i> , TS-402, 502, 505, 507, 524-series	49
Signal blocking, in strong signal areas, <i>Magnavox</i> , 105-series	28
Signal overload <i>Magnavox</i> 103-series	21
prevention of, <i>Muntz</i> , all chassis	61
Size horizontal, loss of, <i>Motorola</i> , TS-292	45
Sound drift, correcting <i>Magnavox</i> , 103-series	21-22
Sound gain, improved <i>Philco</i> , R-191, R194	85-87
insufficient <i>Packard-Bell</i> , 2740, 2840, 3040	75-76

	Pages
Sound i-f circuit, reducing effect of contrast control on, <i>Muntz</i> , 17B2, 17B6, 17B8	59
sound, in fringe areas, improvement of, <i>Packard-Bell</i> , 2740, 2840, 2940, 3040	75
<i>Philco</i> TV-80-series	88-89
Sound limiting, improvement <i>General Electric</i> , 25C101	8-9
Sound, not present, <i>Motorola</i> TS-410-series	51
Sound sensitivity, improvement, <i>Hallcrafters</i> , 1100D, C1100D	10
Squeal in phono position, elimination of, <i>Raytheon</i> , 24T3	102
Stability, horizontal increased, <i>Hoffman</i> , 301, 302	16-17
improved, <i>Pacific Mercury</i> , 150-41, 150-42	66
vertical sync, increasing, <i>Raytheon</i> , 24T3	103
Static change, removal on metal bezel, <i>Motorola</i> , TS-502	53
Static voltage, flashes, <i>Pacific Mercury</i> , 150, 200-series	62
Sweep circuits, disabling, <i>Pacific Mercury</i> , combinations with 155, 160 radio tuners	67
Sweep horizontal, increasing, <i>Motorola</i> , TS-402, 502, 505, 507, 524- series	50
Sync improvement, <i>Raytheon</i> , 21T8, 21T11	102
in fringe areas, <i>Hallcrafters</i> , 1200D-series	10
in noisy areas, <i>Hoffman</i> , 301, 302, 303, 306, 307, 308	16
Sync lockout, troubleshooting, <i>Magnavox</i> , 105, 106, 107-series	23-27
Sync, motorboating, <i>Magnavox</i> , 105-series	28
Sync performance, improved, <i>Philco</i> , R-191, R-194, 84, 85, 86	90-91
Sync range, improving at high contrast <i>Motorola</i> , TS-525-series	54
Sync stability, horizontal improvement of, <i>General Electric</i> , 17T10, 17T11, 17T12	4
improving <i>General Electric</i> , 21T4, 21T5	8
<i>Majestic</i> , 115, 116, 117, 118, 119, 120, 121, 122	33-34
<i>Raytheon</i> , 17T1, 17T2, 21T1, 21T2	98-99
improvement in fringe areas. <i>Magnavox</i> , 104-series	22
Sync, unstable in fringe areas, <i>Hoffman</i> , 196-series	14
Sync, vertical, improvement <i>General Electric</i> , 21T4, 21T5	8
<i>Raytheon</i> , 17T1 17T2, 21T1, 21T2	99

	Pages
improved under noise conditions, <i>Motorola</i> , TS-292 series	44
improved in weak signal areas. <i>Magnavox</i> , 105-series	28
weak and unstable, <i>General Electric</i> , 17T10, 21T2, with uhf tuners	5

T

Tearing, fine-line, <i>Motorola</i> , TS-402, -418, -502, -518, -525, -528, -531, -603, -609	47-48
intermittent, <i>Montgomery Ward</i> , 25WG & 35WG- series	38-39
Tone control range, increasing, <i>Packard-Bell</i> , 2740	77-78
Tone, improvement, <i>Motorola</i> , TS-410-series	51
Tube failure, reduction in high line vol- tage areas, <i>Meck</i> , 9043, 9044, 9045	36-37
6BQ7, <i>Montgomery Ward</i> , models with 6BQ7 tube in tuner	42-43
Tubes, accommodating variety of 12AU7's, <i>Raytheon</i> , 24T3	103
allowing use of various makes of 6CD6's, <i>Muntz</i> , 17B8	60-61
decreasing power drain of 6CD6, <i>Packard-Bell</i> , 2115, 2116, 2117	72
Tuner isolation, improved, <i>Muntz</i> , 17B8	59
Tuning, stiffness in, <i>Raytheon</i> , 21T3	101
Tweet, removal on channel 6, <i>Motorola</i> , TS-602	55
12B4 cathode resistor, preventing overload, <i>Philco</i> , D-204	80

U

Uhf no reception, <i>Montgomery Ward</i> , 35BR-3158A, 3167A, 3168A, 3169A	41-42
Uhf oscillation, maintained at low line voltage, <i>Raytheon</i> , 21T8	102
Uhf reception, adding, <i>Radio Craftsman</i> , RC-100, RC-100A, RC-101, RC-200, RC-201, RC-202	93
Uhf signal source, provided from uhf con- verter, <i>Motorola</i> , chassis with TC-101 uhf converter	56-57

Pages

Uhf split tuning, <i>Hoffman</i> , 171-series with uhf strip	12
Uhf strips, installation of, <i>Montgomery Ward</i> , 25WG-3071D, -3073D, 35WG-3060B, 3070B	39
Uhf tuner, changing output frequency of, <i>Meck</i> 9043, 9044, 9045 with uhf tuner	37
permitting use of, <i>Philco</i> , 94	91
supplying higher B+ for, <i>Motorola</i> , TS-602 series	54

V

Venetian-blind effect, eliminating, <i>Philco</i> , J-2, J-5	83-84
Vertical bars, dark in picture, <i>Packard-Bell</i> , T-1, T-10	69
Vertical bounce, due to sudden line vol- tage change, reduction of, <i>Pacific Mercury</i> 150, 200- series	61-62
Vertical control range, improvement, <i>General Electric</i> , 17C127, 17T15, 17T17, 21C114, 115, 116, 117, 119, 120, 121, 21T10, 11, 12, 14, 15, 19	2-3
Vertical flutter due to line voltage varia- tions, elimination of, <i>Motorola</i> , TS-292 series	45
Vertical hold range, increased, <i>Hoffman</i> , 301, 302	17
Vertical hold control, centering range of, <i>Motorola</i> , TS-602 series	55
<i>Philco</i> , D-181, D-191, D-194	78
increasing range of, <i>Hallcrafters</i> , A1100D, F1100D	9
<i>Raytheon</i> , 17T1, 17T2, 21T1, 21T2	99
Vertical jitter, see Jitter, vertical,	
Vertical linearity adjustments, <i>Magnavox</i> , all chassis with 74-degree picture tube	32
Vertical linearity control, excessive cur- rent through, <i>Kaye-Halbert</i> , 263	21
Vertical linearity, improvement, <i>General Electric</i> , 17T10, 17T11, 17T12, 21T2	4
<i>Hallcrafters</i> , 1100D, G1100D	10
Vertical oscillator, stabilizing, <i>Packard-Bell</i> , 2040	71
Vertical oscillator tube socket, breakdown, <i>Packard-Bell</i> , 2040	71
Vertical output tube, increasing life of, <i>Philco</i> , D-201, D-204, J-2, J-5	79-80
Vertical retrace, improved, <i>Raytheon</i> , 21T8, 21T11	101

	<i>Pages</i>
Vertical retrace suppression, improvement, <i>Philco</i> , D-181, D-208, R-181	78-79, 82, 84
Vertical size control, extending range of, <i>Meck</i> , 9026, 9032, 9033, 9034	36
Vertical stability increased, <i>Hoffman</i> , 301, 302	16-17
Video amplifier, preventing overload of, <i>Packard-Bell</i> , 2040	71
Video capability, increasing, <i>Raytheon</i> , 24T3	103
Video detector, replacement, <i>General Electric</i> , 20C105, 20C106, 20T2, 21C200	5

W

	<i>Pages</i>
Width coil, adjustment, <i>Magnavox</i> , 107-series	29
overheating of, <i>Philharmonic</i> , 800, 900 series	92
Width control, improving range of, <i>Philco</i> , D-181, D-191	79
Width, increasing, <i>Packard-Bell</i> , 2040, 2118	71-72
<i>Raytheon</i> , 24T3	102-103
increasing at low line voltage, <i>Packard-Bell</i> , 1840	70
insufficient, <i>Philco</i> , D-208	81-82
<i>Radio Craftsmen</i> , C-210P	97
reduction, <i>Packard-Bell</i> , 2421, 2422, 2423	74
Whistle, 15-kc, audible, <i>Motorola</i> , all chassis	58

Make TV servicing EASY!

TV MANUFACTURERS' RECEIVER TROUBLE CURES, VOLS. 1-2-3-4-5-6

Positive cures for TV troubles! Exact directions for correcting TV receiver performance "bugs" — straight from the manufacturer's lab! Different data in each volume — over 60 different manufacturers covered! All parts identified exactly the way the maker identifies them! Each volume over 115 pages, $5\frac{1}{2}'' \times 8\frac{1}{2}''$, illustrated. (Cat. Nos. 143, 143-2, 143-3, 143-4, 143-5, 143-6). *Only \$1.80 per volume.*

TV FIELD SERVICE MANUAL, VOL. 1

Edited by Harold Alsberg

Seven year coverage from 1947 to 1953

The first book in this fine series. The most practical service book for the technician who does TV servicing in the home! Includes *tube locations*, picture tube adjustments, front and rear controls, tube complement, tuner and horizontal oscillator adjustments, key voltages, dial stringing, trouble symptoms chart with tubes and parts to check, series filament wiring. Covers: Admiral, Affiliated Retailers (Artone), Aimcee (AMC), Air King, Air Marshall, Allied Purchasing, Andrea, Arvin, and Automatic. 128 pages, $5\frac{1}{2}'' \times 8\frac{1}{2}''$. (Cat. No. 155.) *Only \$2.10.*

VOLUME 2

Bendix, Capehart, CBS-Columbia, Crosley, Du Mont. 160 ($5\frac{1}{2}'' \times 8\frac{1}{2}''$) pages. (Cat. No. 155-2.) *Only \$2.40.*

VOLUME 3

Emerson and Fada. 128 ($5\frac{1}{2}'' \times 8\frac{1}{2}''$) pages. (Cat. No. 155-3.) *Only \$2.10.*

VOLUME 4

GE, Hallicrafters and Hoffman. 160 ($5\frac{1}{2}'' \times 8\frac{1}{2}''$) pages. (Cat. No. 155-4.) *Only \$2.40.*

PICTURE BOOK OF TV TROUBLES, VOLS. 1, 2 & 3

By the Rider Laboratory Staff

A new "TV Case History" series, designed to provide a better understanding of how to diagnose TV receiver troubles by means of picture and waveform observation. All material is the result of actual troubleshooting done in the Rider labs! Dozens of "faulty" picture tube pattern and waveform illustrations (normal and abnormal). A MUST for every service technician!

VOL. 1: Horizontal AFC-Oscillator Circuits. (Cat. No. 168.) *Only \$1.35.*

VOL. 2: Vertical Sweep-Deflection Circuits. (Cat. No. 168-2.) *Only \$1.80.*

VOL. 3: Video I-F & Video Amplifier Circuits. (Cat. No. 168-3.) *Only \$1.80.*

OBTAINING & INTERPRETING TEST SCOPE TRACES

By John F. Rider

Explains scope traces in clear, non-mathematical terms that everyone can understand! Eight hundred traces of all types of AM and FM radio receivers, TV receivers, audio amplifiers, power supplies and transmitters! Written to be used by service technicians, students, junior engineers, lab technicians . . . by anyone and everyone who works with the cathode-ray oscilloscope! 192 ($5\frac{1}{2}'' \times 8\frac{1}{2}''$) pages, illustrated. (Cat. No. 146.) *Only \$2.40.*

HOW TO USE TEST PROBES

By Alfred A. Ghirardi & Robert G. Middleton

Written by two of the country's leading electronics experts, this book covers all types of test probes used with VOM's, VTVM's, and scopes. The one book that tells you what probe to use, where to use it, and how to use it! 165 pages, $5\frac{1}{2}'' \times 8\frac{1}{2}''$, illustrated. (Cat. No. 165.) *Only \$2.90.*

JOHN F. RIDER PUBLISHER, INC., 480 CANAL ST., N. Y. 13, N. Y.